



MANUALE STAZIONE DI SERVIZIO

1Q000725 (IT-FR-DE-ES-NL-EN-PT-EL)



Vespa GTS 300 HPE ABS



MANUALE STAZIONE DI SERVIZIO

Vespa GTS 300 HPE ABS

The descriptions and images in this publication are given for illustrative purposes only. While the basic features as described and illustrated in this manual remain unchanged, Piaggio & C. S.p.A. reserves the right, at any time and without being required to update this publication beforehand, to make any changes to components, parts or accessory supplies which it deems necessary to improve the product, or which are required for manufacturing or commercial reasons.

Not all the versions shown in this publication are available in every country. Availability of the individual versions must be verified with the official PIAGGIO sales network.

© Copyright 2019 - Piaggio & C. S.p.A. All rights reserved. Reproduction of this publication in whole or in part is prohibited.

Piaggio & C. S.p.A. Viale Rinaldo Piaggio, 25 - 56025 PONTEDERA (PI), Italy

www.piaggio.com

MANUALE STAZIONE DI SERVIZIO

Vespa GTS 300 HPE ABS

Questo manuale per stazioni di servizio è stato realizzato da Piaggio & C. Spa per essere utilizzato dalle officine dei concessionari e sub-agenzie Piaggio-Gilera. Si presuppone che chi utilizza questa pubblicazione per la manutenzione e la riparazione dei veicoli Piaggio, abbia una conoscenza base dei principi della meccanica e dei procedimenti inerenti la tecnica della riparazione dei veicoli. Le variazioni importanti nelle caratteristiche dei veicoli o nelle specifiche operazioni di riparazione verranno comunicate attraverso aggiornamenti di questo manuale. Non si può comunque realizzare un lavoro completamente soddisfacente se non si dispone degli impianti e delle attrezzature necessarie, ed è per questo che vi invitiamo a consultare le pagine di questo manuale riguardanti l'attrezzatura specifica e il catalogo degli attrezzi specifici.

N.B. Provides key information to make the procedure easier to understand and carry out.

CAUTION Refers to specific procedures to carry out for preventing damages to the vehicle.

WARNING Refers to specific procedures to carry out to prevent injuries to the repairer.



Personal safety Failure to completely observe these instructions will result in serious risk of personal injury.



Safeguarding the environment Sections marked with this symbol indicate the correct use of the vehicle to prevent damaging the environment.



Vehicle intactness The incomplete or non-observance of these regulations leads to the risk of serious damage to the vehicle and sometimes even the invalidity of the guarantee.



INDEX OF TOPICS

PRE-DELIVERY

PRE DE

TECHNICAL DATA

DT

TOOLING

TOOL

MAINTENANCE

MAIN

ELECTRICAL SYSTEM

ELE SYS

ENGINE FROM VEHICLE

ENG VE

ENGINE

ENG

INJECTION

INJEC

SUSPENSIONS

SUSP

BRAKING SYSTEM

BRAK SYS

COOLING SYSTEM

COOL SYS

CHASSIS

CHAS

INDEX OF TOPICS

PRE-DELIVERY

PRE DE

Carry out the listed tests before delivering the vehicle.

Warning - Handle fuel with care.

Aesthetic inspection

Appearance check:

- Paintwork
 - Fitting of plastics
 - Scratches
 - Dirt
-

Tightening torques inspection

Lock check

Check to make sure that the marking in coloured mark is present on the:

- Safety fasteners
- Fastening screws

Safety fasteners:

- Front shock absorber lower fastener
 - Rear shock absorber lower fastener
 - Swinging arm pin - Engine
 - Front wheel brake calliper
 - Rear wheel brake calliper
 - Coolant delivery and return pipe ties on the coolant pump cover
-

Electrical system

- Main switch
- Lights: high beam lights, low beam lights, tail lights and their warning lights
- Headlight adjustment according to the regulations currently in force
- Brake light operation by using the RH and LF brake lever
- Turn indicators and their warning lights
- Instrument lighting
- instruments: fuel and temperature indicator
- Instrument panel lights
- Horn
- Electric starter
- Engine stopping with emergency stop switch
- electric saddle opening button

CAUTION

TO ENSURE MAXIMUM PERFORMANCE, THE BATTERY MUST BE CHARGED BEFORE USE. INADEQUATE CHARGING OF THE BATTERY WITH A LOW LEVEL OF ELECTROLYTE BEFORE IT IS FIRST USED SHORTENS THE LIFE OF THE BATTERY.

CAUTION

WHEN INSTALLING THE BATTERY, ATTACH THE POSITIVE LEAD FIRST AND THEN THE NEGATIVE ONE.

WARNING

BATTERY ELECTROLYTE IS TOXIC AND IT MAY CAUSE SERIOUS BURNS. IT CONTAINS SULPHURIC ACID. AVOID CONTACT WITH EYES, SKIN AND CLOTHING.

IF IT ACCIDENTALLY COMES INTO CONTACT WITH YOUR EYES OR SKIN, WASH WITH ABUNDANT WATER FOR APPROX. 15 MIN. AND SEEK IMMEDIATE MEDICAL ATTENTION.

IF ACCIDENTALLY SWALLOWED, IMMEDIATELY DRINK LARGE QUANTITIES OF WATER OR VEGETABLE OIL. SEEK IMMEDIATE MEDICAL ATTENTION.

BATTERIES PRODUCE EXPLOSIVE GAS; KEEP CLEAR OF NAKED FLAMES, SPARKS OR CIGARETTES. VENTILATE THE AREA WHEN RECHARGING INDOORS. ALWAYS WEAR EYE PROTECTION WHEN WORKING IN THE PROXIMITY OF BATTERIES.

KEEP OUT OF THE REACH OF CHILDREN.

CAUTION

NEVER USE FUSES WITH A CAPACITY HIGHER THAN THAT RECOMMENDED. USING A FUSE OF UNSUITABLE RATING MAY SERIOUSLY DAMAGE THE VEHICLE OR EVEN CAUSE A FIRE.

Levels check

Level check:

- Hydraulic brake system liquid level
 - Rear hub oil level
 - Engine coolant level
 - Engine oil level
-

Road test

Test ride:

- Cold start
- Instrument operations
- Response to throttle control
- Stability on acceleration and braking
- Front and rear brake efficiency
- Front and rear suspension efficiency
- Abnormal noise

N.B.

PERFORM THE ASR SYSTEM'S CALIBRATION PROCEDURE DURING THE ROAD TEST.

Static test

Static control after the test drive:

- Hot engine restart
 - Minimum seal (turning the handlebar)
-

- Uniform steering rotation
- Possible losses
- electric radiator fan operation

CAUTION

CHECK AND ADJUST TYRE PRESSURE WITH TYRES AT AMBIENT TEMPERATURE.

CAUTION

NEVER EXCEED THE RECOMMENDED INFLATION PRESSURES SINCE THE TYRES MAY BURST.

Functional inspection

Functional Checks:

- Hydraulic braking system: lever travel
- Clutch: proper functioning check
- Engine: proper general functioning and no abnormal noise check
- Other: papers check, chassis and engine number check, tools and equipment, licence plate fitting, lock check, tyre pressure check, rear-view mirror and any accessory fitting

Instruments start-up

FOR SUPERTECH VERSION

The **MODE** joystick allows the cyclic display of the information shown on the multifunction panel of the digital display. It also allows navigation in the «**settings**» menu and setting various parameters. This is possible by pressing or moving the joystick in the four directions with short or long presses.

N.B.



"PRESS BRIEFLY AND RELEASE": PRESS THE BUTTON AND RELEASE WITHIN 0.5 SECONDS;
"PRESS AND HOLD": PRESS THE BUTTON AND HOLD FOR AT LEAST 2 SECONDS.

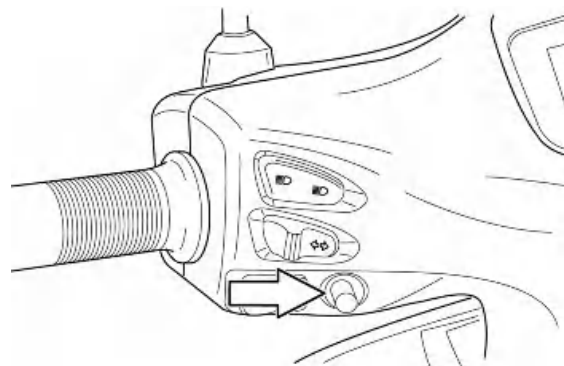

SETTINGS MENU

When the vehicle is at a standstill, briefly press the joystick up or down several times to display the «**settings**» function at the centre of the multifunctional panel. The «**settings**» menu can be accessed with a prolonged press on the central button of the joystick .



Briefly press the joystick upward or downward to highlight the **"Configuration"** function.

Briefly press the central button of the joystick to enter the menu.



MEASUREMENT UNITS MENU (UNITS)

Highlight the **"Units"** function via a short press on the central button of the joystick and enter the menu where it is possible to configure:

- Speed
- Temperature



SETTING THE SPEED UNIT OF MEASUREMENT (SPEED)

Highlight the **"Speed"** function. Via a short press on the central button of the joystick, enter the menu.



Select the desired format between Km/h or mph. The selection excludes the others.



SETTING THE TEMPERATURE UNIT OF MEASUREMENT (TEMPERATURE)

Highlight the "Temperature" function. Via a short press on the central button of the joystick, enter the menu.

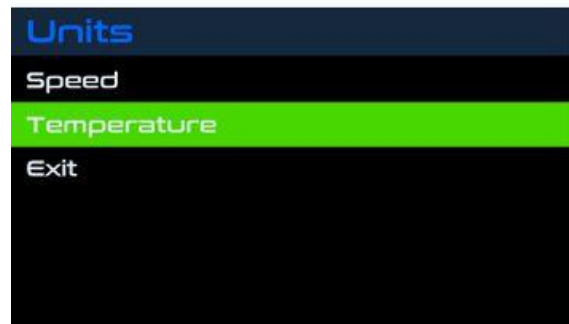

Select the desired format between °C or °F. The selection excludes the others.



MY 2019 VERSION

SELECTION OF UNIT OF MEASUREMENT KM OR MILES

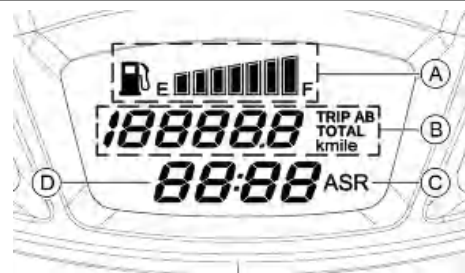

SELECTING KM OR MILES AS UNIT OF MEASUREMENT B

Press the **MODE** briefly to cycle through the modes and select **TOTAL** odometer mode, then turn the ignition switch to **OFF**.

Turn the ignition switch to **ON** while pressing and holding the **MODE** button.

Release the **MODE** button for 2 to 4 seconds.



WARNING

TO CHANGE FROM "KM" A "MILE" IT IS NECESSARY TO SET THE MULTIFUNCTION INDICATOR TO TOTAL ODOMETER (TOTAL).

CAUTION



FOR SAFETY, THIS SELECTION PROCEDURE IS ONLY PERMITTED AT A VEHICLE SPEED OF 0 KM/H.

ASR SYSTEM

The ASR system is a driving aid that assists the driver in acceleration manoeuvres, particularly on low-grip surfaces or under conditions that can cause sudden back-wheel slippage. The ASR in these situations automatically intervenes by reducing engine output within the limit imposed by the grip conditions, contributing significantly to the maintenance of stability the vehicle.

WARNING



THE ASR SYSTEM IS BASED ON THE RECOGNITION OF SPEED DIFFERENCES BETWEEN FRONT AND REAR WHEEL. IN ORDER FOR THE SYSTEM TO MAINTAIN MAXIMUM EFFICIENCY IN ALL CONDITIONS, THE CALIBRATION PROCEDURE MUST BE PERFORMED EVERY TIME, EVEN IN CASE OF REPLACEMENT OF JUST ONE TIRE. FOR THE CALIBRATION OF THE CONTROL UNIT PERFORM THE PROCEDURE BELOW.

ASR BUTTON 1: activation / deactivation.

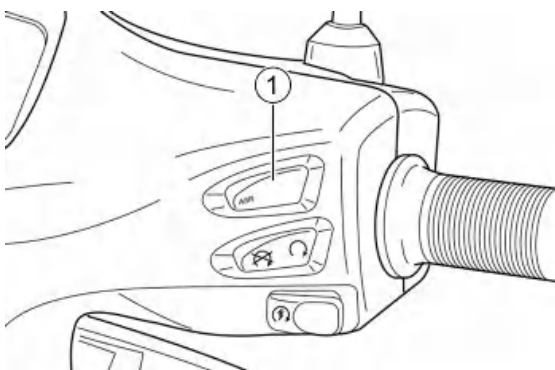

ASR ICON 2: ASR status indicator icon.

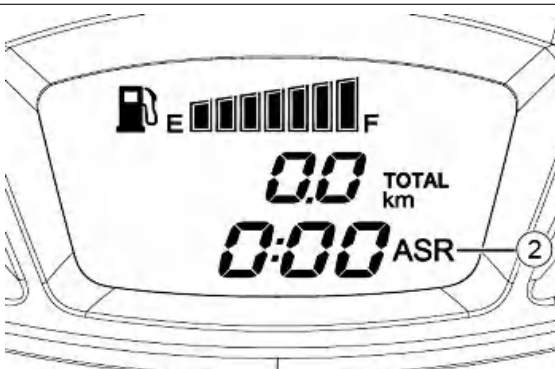



ASR ICON FLASHING MODE:

- Frequency of 5 flashes per second (5Hz), with vehicle running: The system is functioning correctly and is active (poor grip conditions, engine power limiting in effect); ride with extreme care, as the grip limit has been exceeded; restore the vehicle safety conditions by gently reducing the throttle opening.

- Frequency of 1 flash per second (2 Hz), with the key in "ON" position and the vehicle at a standstill: The system is active and the calibration is performed. The corresponding icon will switch off as soon as the ABS system becomes operational.

- Frequency of 1 flash every 2 seconds (0.5 Hz), with the key in "ON" position and the vehicle at a standstill: the system calibration is in progress.

- Switched on steady can have three meanings:

1. calibration procedure performed incorrectly. Perform a new calibration;
2. the ASR system is not operating and will not intervene in case of loss of grip;
3. the ASR system has been willingly disabled.
 - If the deactivation was voluntary (by pressing the appropriate button "1" for 1 second with the engine running) it is recommended to reactivate the system as soon as possible.
 - If the system was NOT deactivated voluntarily, this indicates a failure of the ASR system: In this case, proceed with the system diagnosis and reactivation.

To ensure maximum safety of the vehicle it is advisable to keep the system active. Deactivation may be necessary only in case of starting with very low grip surfaces (mud, snow) on which the operation of the ASR could actually prevent the movement of the vehicle.

N.B.

UPON KEY "ON", THE ASR ICON FLASHES AT THE SAME FREQUENCY AS THE ABS INDICATOR LIGHT TO INDICATE THAT SYSTEM DIAGNOSIS IS IN PROGRESS. IF NO ERRORS ARE FOUND, THE ASR ICON AND THE ABS INDICATOR LIGHT SWITCH OFF AT THE SAME TIME ONCE THE VEHICLE SPEED EXCEEDS 5 Km/h (3 mph).

IF THE ICON AND INDICATOR LAMP DO NOT FLASH WHEN THE ENGINE IS STARTED, THE SYSTEM MAY NOT BE WORKING.

WARNING



THE ASR SYSTEM IS ACTIVATED AT EVERY "ON" POSITIONING OF THE IGNITION SWITCH.

IF DISABLED BY THE USER, THE ASR SYSTEM KEEPS THE STATE OF INACTIVITY ONLY IF THE VEHICLE IS OFF, BY USING THE ENGINE STOP SWITCH; AT THE NEXT KEY ON THE ASR SYSTEM IS ENABLED AUTOMATICALLY.

CAUTION



IT IS EMPHASISED THAT THE RIDING AUXILIARY SYSTEM CANNOT CHANGE THE PHYSICAL LIMITS OF GRIP AND IS NOT A SUBSTITUTE FOR PROPER MANAGEMENT OF POWER, BOTH ON STRAIGHT STRETCHES AND IN TURNS. THEREFORE, IT IS RECOMMENDED TO ALWAYS USE THE VEHICLE WITH THE UTMOST CARE AND IN ACCORDANCE WITH THE REGULATIONS IN FORCE.

CAUTION



AT LOW SPEED, LESS THAN 5 Km/h (3 mph), THE ASR SYSTEM IS NOT OPERATIONAL. IT IS RECOMMENDED TO PAY PARTICULAR ATTENTION IN THE EVENT OF ACCELERATION FROM STANDSTILL IN CONDITIONS OF LOW GRIP, ESPECIALLY IN THE FIRST METRES.

N.B.

IN CASE OF ROAD DISCONNECTIONS THERE COULD BE SHORT ACTIVATIONS OF THE ASR SYSTEM. SUCH EVENT APPEARS UNDER NORMAL OPERATION CONDITIONS OF THE VEHICLE.

N.B.

THE DEVICE PREVENTS IMPRESSING ON THE REAR HIGH SPEED ROTATION WHEEL WITH THE VEHICLE ON THE CENTRE STAND. IT IS RECOMMENDED NOT TO INSIST WITH THE THROTTLE GRIP IN THIS PARTICULAR CONDITION.

CAUTION



A POOR STATE OF MAINTENANCE OF THE TYRES CAN RESULT IN ABNORMAL OPERATION OF THE ASR SYSTEM.

IN CASE OF REPEATED INTERVENTIONS OF THE ASR, EVEN ON ROAD SURFACES WITH GOOD GRIP OR SMALL THROTTLE OPENINGS, IT IS NECESSARY TO CHECK FOR WEAR AND/OR THE STATE OF INFLATION OF TYRES FIRST.

CAUTION



IN THE EVENT OF MALFUNCTION OF THE BATTERY, THE ABS - ASR SYSTEM TURNS OFF.

predelivery ASR SYSTEM calibration/ ECU replacement

In case of predelivery vehicle, or following the replacement of the engine management control unit, **on which the ASR system initialisation procedure has never been performed**, proceed as follows.

After key "ON", the ABS indicator light flashes and the ASR icon "2" **is switched on steady**.

1) Start the vehicle and ride a short distance of more than 5 km/h (3 mph) and wait for the flashing of the ASR warning light to stop. The ASR icon stays switched on steady.

2. Stop the vehicle and leave the engine running at idle speed for at least 3 seconds.

3. Press the engine start button and the ASR on/off button "1" simultaneously for at least 4 seconds (**pulling the left brake lever has no effect**).

4. The activation of the procedure will be confirmed by the slow flashing switched on ASR icon "2" (1 flash every 2 seconds).
5. Accelerate to a constant speed of 30 km/h (18.7 mph) and maintain it for at least to 10 seconds.
6. The end of the procedure will be indicated by turning off the ASR icon "2".
7. Once the procedure is completed, turn the ignition switch to "OFF" and wait at least 30 seconds for the next key "ON".
8. In case of failure to complete the procedure within 2 minutes the ASR icon "2" will stay on steady and the ASR will remain disabled until the next key "OFF".
9. To restart the ASR, it is necessary to turn the key to "ON", and repeat the procedure until achieving positive result.

ASR SYSTEM CALIBRATION following the replacement of one or both tires

If one or both tires are replaced, proceed in the following manner.

After key "ON", the ABS indicator light and the ASR icon "2" **flash at the same frequency (fast flashing)**.

1. Start the vehicle and ride a short distance of more than 5 km/h (3 mph) and wait for the flashing of the ASR warning light and of the ABS icon to stop.
 2. Stop the vehicle and leave the engine running at idle speed for at least 3 seconds.
 3. Turn the ASR system off by pressing the specific button "1" on the handlebar and check that the ASR disabling icon "2" is switched on steady.
 4. Press the engine start button and the ASR on/off button "1" simultaneously for at least 4 seconds **(pulling the left brake lever has no effect)**.
 5. The activation of the procedure will be confirmed by the slow flashing switched on ASR icon "2" (1 flash every 2 seconds).
 6. Accelerate to a constant speed of 30 km/h (18.7 mph) and maintain it for at least to 10 seconds.
 7. The end of the procedure will be indicated by turning off the ASR icon "2".
 8. Once the procedure is completed, turn the ignition switch to "OFF" and wait at least 30 seconds for the next key "ON".
 9. In case of failure to complete the procedure within 2 minutes the ASR icon "2" will stay on steady and the ASR will remain disabled until the next key "OFF".
 10. To restart the ASR, it is necessary to turn the key to "ON", and repeat the procedure until achieving positive result.
-

INDEX OF TOPICS

TECHNICAL DATA

DT

This section describes the general specifications of the vehicle.

Rules

This section describes general safety rules for any maintenance operations performed on the vehicle.

Safety rules

- If work can only be done on the vehicle with the engine running, make sure that the premises are well ventilated, using special extractors if necessary; never let the engine run in an enclosed area. Exhaust fumes are toxic.
 - The battery electrolyte contains sulphuric acid. Protect your eyes, clothes and skin. Sulphuric acid is highly corrosive; in the event of contact with your eyes or skin, rinse thoroughly with abundant water and seek immediate medical attention.
 - The battery produces hydrogen, a gas that can be highly explosive. Do not smoke and avoid sparks or flames near the battery, especially when charging it.
 - Fuel is highly flammable and it can be explosive given some conditions. Do not smoke in the working area, and avoid naked flames or sparks.
 - Clean the brake pads in a well-ventilated area, directing the jet of compressed air in such a way that you do not breathe in the dust produced by the wear of the friction material. Even though the latter contains no asbestos, inhaling dust is harmful.
-

Maintenance rules

- Use original PIAGGIO spare parts and lubricants recommended by the Manufacturer. Non-original or non-conforming spare parts may damage the vehicle.
 - Use only the appropriate tools designed for this vehicle.
 - Always use new gaskets, sealing rings and cotter pins upon refitting.
 - After removal, clean the components using non-flammable or low flash-point solvents. Lubricate all the work surfaces, except tapered couplings, before refitting these parts.
 - After refitting, make sure that all the components have been installed correctly and work properly.
 - Use only equipment with metric sizes for removal, service and reassembly operations. Metric bolts, nuts and screws are not interchangeable with coupling members using English measurements. Using unsuitable coupling members and tools may damage the vehicle.
 - When carrying out maintenance operations on the vehicle that involve the electrical system, make sure the electrical connections have been made properly, particularly the ground and battery connections.
-

Vehicle identification

Identification registration numbers are made up of a prefix and a number, stamped on the frame and on the engine. The serial number must always be indicated when ordering spare parts. We recommend checking that the frame registration number stamped on the vehicle corresponds with that on the vehicle documentation.

CAUTION



PLEASE REMIND THAT ALTERING IDENTIFICATION REGISTRATION NUMBERS CAN LEAD TO SERIOUS PENAL SANCTIONS (IMPOUNDING OF THE VEHICLE, ETC.).

Chassis number

The chassis number «**A**» is stamped near the fuel tank.

To read it, proceed as follows:

- lift the saddle;



- lift the helmet compartment by removing it.

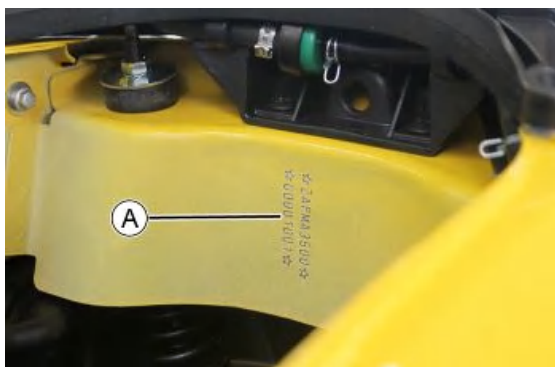

Engine number

The engine number «**B**» is stamped near the rear left shock absorber lower support.

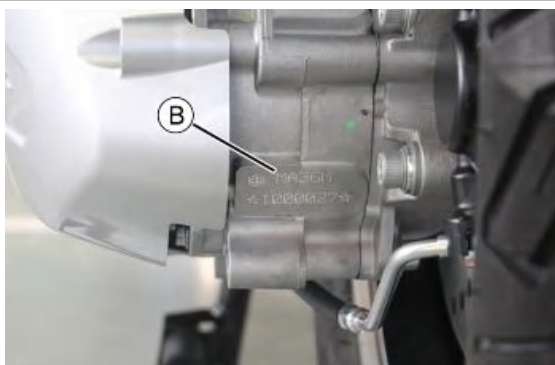

Vehicle data

EUROPE VERSION

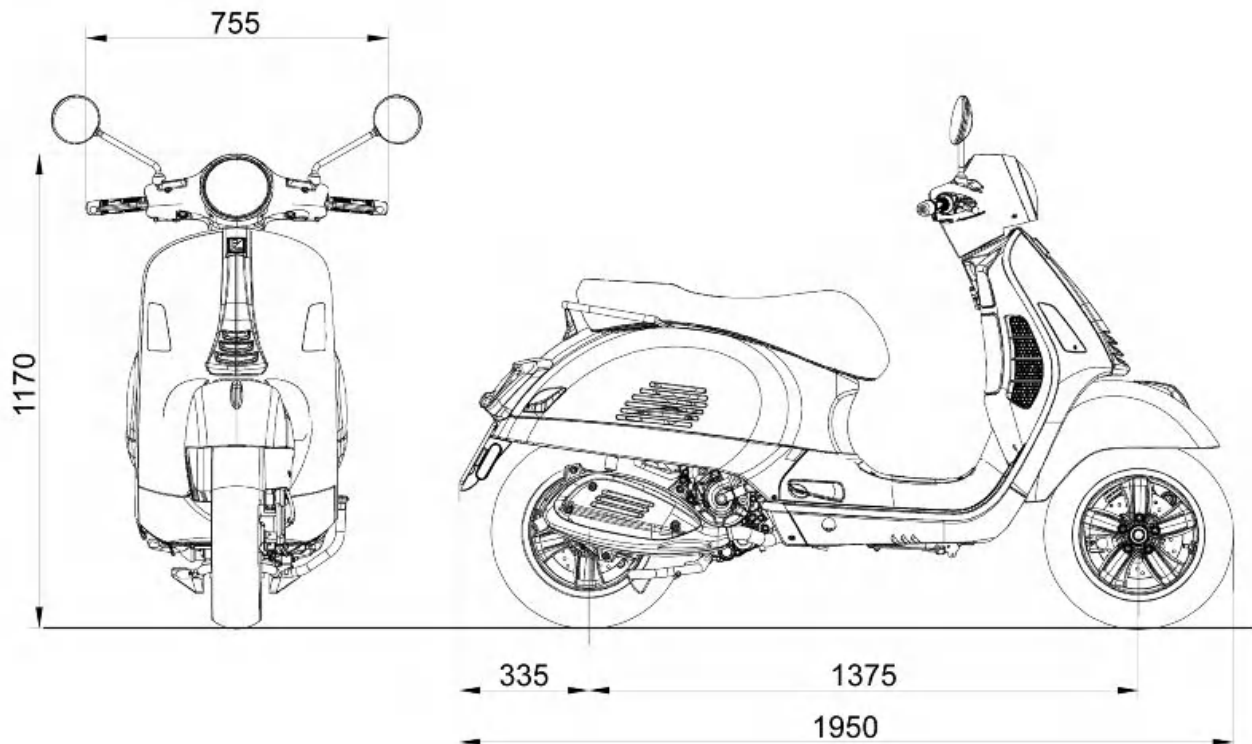

VEHICLE TECHNICAL DATA

Specification	Desc./Quantity
Chassis	Stamped plate supporting body.
Front suspension	Single arm suspension (cantilever wheel) fitted with a dual-chamber hydraulic shock absorber with coaxial spring.
Rear suspension	Two double-acting shock absorbers, adjustable to four positions at pre-loading.
Front brake	Ø 220 mm hydraulically operated disc brake controlled from RH handlebar lever; braking assisted by ABS system.
Rear brake	Ø 220 mm hydraulically operated disc brake controlled from LH handlebar lever; braking assisted by ABS system.
Wheel rims type	Light alloy.
Front rim	12" x 3.00
Rear rim	12" x 3.00
Front tire	120/70 - 12" 51P Tubeless
Rear tire	Tubeless 130/70 - 12" 62P
Front tire pressure (with passenger)	1.8 bar (1.8 bar)
Rear tire pressure (with passenger)	2.0 bar (2.2 bar)
Kerb mass	160 kg
Maximum technically permissible weight at full load	340 kg
Battery	12V-10Ah

FOR USA-LATAM VERSION

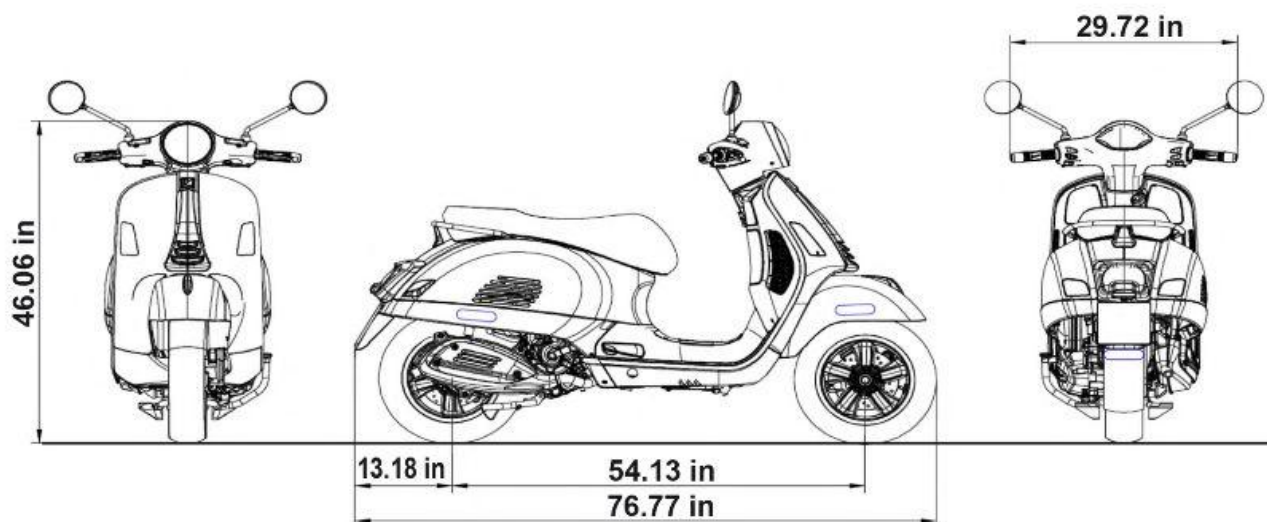

VEHICLE TECHNICAL DATA

Specification	Desc./Quantity
Chassis	Stamped plate supporting body.
Front suspension	Single arm suspension (cantilever wheel) fitted with a dual-chamber hydraulic shock absorber with coaxial spring.
Rear suspension	Two double-acting shock absorbers, adjustable to four positions at pre-loading.
Front brake	Ø 8.7 (220 mm) hydraulically operated disc brake controlled from RH handlebar lever; braking assisted by ABS system.
Rear brake	Ø 8.7 in (220 mm) hydraulically operated disc brake controlled from LH handlebar lever; braking assisted by ABS system.
Wheel rims type	Light alloy.
Front rim	12" x 3.00
Rear rim	12" x 3.00
Front tire	120/70 - 12" 51P Tubeless
Rear tire	Tubeless 130/70 - 12" 62P
Front tire pressure (with passenger)	26 psi / 1.8 bar (-)
Rear tire pressure (with passenger)	29 psi / 2.0 bar (37.7 psi (2.6 bar)
Kerb weight	354.2 lb (161 Kg)
Maximum weight limit	774.4 lb (352 Kg)
Battery	12V-10Ah

Engine Data

ENGINE SPECIFICATIONS

Specification	Desc./Quantity
Type	Single cylinder 4-stroke
Engine capacity	278 cm ³
Bore x Stroke	75x63 mm
Compression ratio	11 ± 0.5: 1
Idle engine speed	1,700 ± 100 rpm
Timing system	4 valves, single overhead camshaft, chain-driven.
Valve clearance (cold engine)	Intake: 0.10 mm Exhaust: 0.15 mm

Specification	Desc./Quantity
Maximum power	17.5 kW at 8250 rpm
Maximum torque	26.0 Nm at 5250 rpm
Transmission	CVT expandable pulley variator with torque server, V-belt, self-ventilating dry automatic centrifugal clutch and transmission housing with forced-circulation air cooling.
Final drive reduction gear	Gear reduction unit in oil bath.
Lubrication	Engine lubrication with lobe pump (inside crankcase), chain-driven, with double filter: mesh and paper.
Cooling	Forced coolant circulation system.
Starting	Electric
Ignition	Electronic inductive discharge ignition, high efficiency, with separate HV coil.
Ignition advance	α/N three-dimensional map managed by control unit
Spark plug	NGK MR7BI-8
Power supply	Electronic injection with Ø 32-mm throttle body and electric fuel pump.
Fuel	Unleaded gasoline E10 (95 R.O.N.)
Exhaust silencer	Absorption-type exhaust silencer with a 3-way catalytic converter and lambda probe.
Emissions compliance	EURO 4

Capacities

CAPACITY

Specification	Desc./Quantity
Engine oil	1.3 l
Transmission oil	250 cm ³
Cooling system fluid	~ 2 l
Fuel tank	8.5 ± 0.5 litres

MEASUREMENT UNITS CONVERSION - FROM THE ANGLO-SAXON SYSTEM TO THE INTERNATIONAL SYSTEM (I.S.).

Specification	Desc./Quantity
1 Inch (in)	25.4 Millimetres (mm)
1 Foot (ft)	0.305 Metres (m)
1 Mile (mi)	1.609 Kilometres (km)
1 US gallon (gal US)	3.785 Litres (l)
1 Pound (lb)	0.454 Kilograms (Kg)
1 Cubic inch (in ³)	16.4 Cubic centimetres (cm ³)
1 Pound per foot (lbf ft)	1.356 Newton metres (N m)
1 Mile per hour (mi/h)	1.602 Kilometres per hour (km/h)
1 Pound per square foot (PSI)	0.069 (bar)
1 Fahrenheit (°F)	32+(9/5) Celsius (°C)

Tightening Torques

STEERING ASSEMBLY

Name	Torque in Nm
Upper steering ring nut	35 - 40
Lower steering ring nut	12 - 14
Handlebar fixing screw	50 - 55
Fixing screws for the handlebar control unit U-bolts	7 - 10

FRAME ASSEMBLY

Name	Torque in Nm
Swinging arm pin - engine	64 - 72
swinging arm bolt - body shell	76 to 83
Engine and vehicle side swinging arm junction bolt	33 - 41
Bolt of the Silent block support plate	42 to 52

Name	Torque in Nm
Central stand bolt	32 - 40
Side stand fixing bolt	35 - 40

FRONT SUSPENSION

Name	Torque in Nm
Screw fixing the shock absorber to the shock absorber - calliper attachment plate	20 to 27
Wheel axle nut	74 - 88
Wheel screw	20 - 25
Screw fixing rear mudguard to steering	5 - 6.5
shock absorber upper clamp	20 to 30

FRONT BRAKE

Name	Torque in Nm
Brake fluid pump-hose joint	20 - 25
Brake fluid pipe-calliper fitting	19 - 24
Screw fixing calliper to the shock absorber - calliper plate attachment	24 to 27
Disc tightening screw	6 (Apply LOCTITE 242 threadlock, medium strength)
Oil bleed screw	12 - 16
Pad fastening pin	19.6 - 24.5
Brake pump reservoir screws	1.5 - 2
Brake disc screws	8 to 10

REAR SUSPENSION

Name	Torque in Nm
Retainer for left shock absorber to crankcase support plate	20 - 25
Shock absorber lower fitting	40 - 45
Shock absorber upper fitting	20 - 25
Rear wheel axle	104 ÷ 126
Screw fixing wheel to hub	20 - 25
Screws for silencer - shock absorber support arm on engine	20 - 25 (The two screws must be tightened after having done so with the rear wheel axle nut at the specified torque. Safety fasteners: see «Pre-delivery Operations»)
Engine- and vehicle-side swinging arm junction bolt	40 - 45

REAR BRAKE

Name	Torque in Nm
Brake fluid pump-hose joint	20 - 25
Brake fluid pipe-calliper fitting	20 - 25
Rear disc tightening bolt	11 to 13
Oil bleed screw	12-16
Calliper to engine tightening screw	20 - 25
Brake pump reservoir screws	1.5 - 2
Callipers fitting screw	30 - 33

SILENCER

Name	Torque in Nm
Silencer heat guard fixing screw	4 - 5
Screw used to fasten silencer to supporting arm	20 - 25
Lambda probe tightening on exhaust manifold	40 - 50
Manifold/silencer joint tightening torque	12 - 13
Manifold - silencer diaphragm tightening clamp	16 - 18

LUBRICATION

Name	Torque in Nm
Hub oil drainage plug	15 to 17
Oil filter on crankcase fitting	27 - 33
Engine oil drainage plug/ mesh filter	24 to 30
Oil filter	4 - 6
Oil pump cover screws	7 - 9
Screws fixing oil pump to the crankcase	5 to 6

Name	Torque in Nm
Oil pump command sprocket screw	10 - 14
Oil pump cover plate screws	4 - 6
Oil sump screws	10 - 14
Minimum oil pressure sensor	12 - 14

CYLINDER HEAD

Name	Torque in Nm
Spark plug	12 - 14
Cylinder head cover screws	6 - 7
Nuts fixing head to cylinder	$7 \pm 1 + 10 \pm 1 + 270^\circ$
Head fixing side screws	11 - 12
Starter ground screw	7 to 8.5
Tappet adjustment check nut	6 - 8
Inlet manifold screws	11 to 13
Timing chain tensioner slider screw	10 - 14
Starter counterweight support screw	11 to 15
Timing chain tensioner support screw	11 to 13
Timing chain tensioner central screw	5 to 6
Camshaft retention plate screw	4 - 6

TRANSMISSION

Name	Torque in Nm
Belt support roller screw	11 to 13
Clutch unit nut on driven pulley	45 - 50
Driver pulley nut	75 - 83
Transmission cover screws	11 - 13 Nm
Driven pulley shaft nut	54 - 60
Rear hub cover screws	24 to 27

FLYWHEEL

Name	Torque in Nm
Flywheel cover screw	11 to 13
Stator assembly screws	3 - 4 (Apply LOCTITE medium type 242 threadlock)
Flywheel nut	94 - 102
Pick-up fixing screws	3 - 4
Screw fixing freewheel to flywheel	13 - 15

CRANKSHAFT AND CASE

Name	Torque in Nm
Internal engine crankcase bulkhead (transmission-side half shaft) screws	4 - 6
Engine-crankcase coupling screws	11 to 13
Starter screws	11 to 13
Crankcase timing cover screws	3.5 - 4.5 (Apply LOCTITE medium type 242 threadlock)

COOLING

Name	Torque in Nm
Water pump rotor cover	3 - 4
Thermostat cover screws	3 - 4
Bleeder screw	3

Overhaul data

Assembly clearances

Cylinder - piston assy.

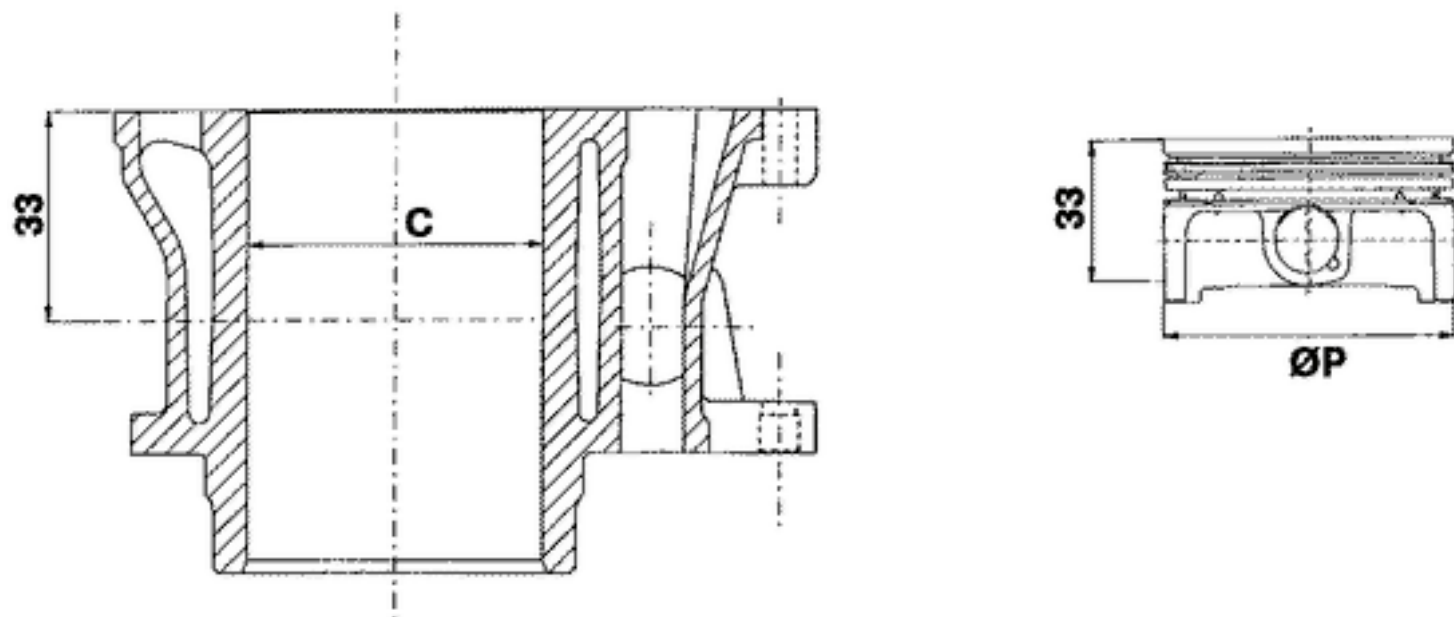

CYLINDER - PISTON

Specification	Desc./Quantity
Plunger diameter	74.967 +0.014 -0.014 mm
Cylinder diameter	75 +0.038 +0.01 mm

COUPLING CATEGORIES

Name	Initials	Cylinder	Piston	Play on fitting
cylinder - piston	M	75.01 ÷ 75.017	74.953 ÷ 74.960	0.050 ÷ 0.064
cylinder - piston	N	75.017 ÷ 75.024	74.960 ÷ 74.967	0.050 ÷ 0.064
cylinder - piston	O	75.024 ÷ 75.031	74.967 ÷ 74.974	0.050 ÷ 0.064
cylinder - piston	P	75.031 ÷ 75.038	74.974 ÷ 74.981	0.050 ÷ 0.064

N.B.

THE PISTON MUST BE INSTALLED WITH THE ARROW FACING TOWARDS THE EXHAUST SIDE, THE PISTON RINGS MUST BE INSTALLED WITH THE WORD «TOP» OR THE STAMPED MARK FACING UPWARDS.

- Check the pin external diameter.

Characteristic

Pin external diameter

16 +0 -0.004 mm

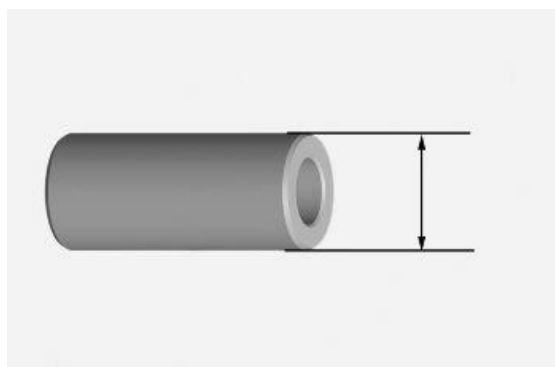

- Measure the diameter of the bearings on the piston.

Characteristic

Standard diameter

16 +0.006 +0.001 mm

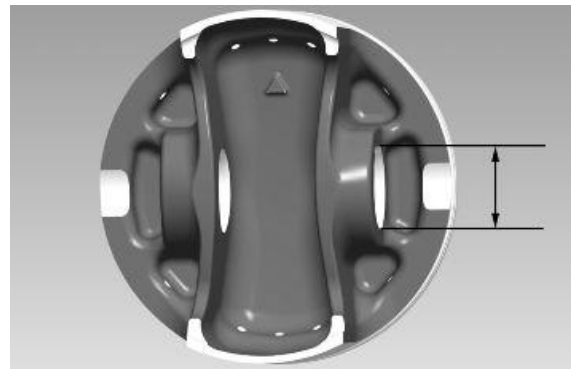

- Calculate the piston pin coupling clearance.

N.B.

THE PIN HOUSINGS HAVE 2 LUBRICATION CHANNELS. FOR THIS REASON, MEASUREMENT MUST BE MADE ACCORDING TO THE PISTON AXIS

Characteristic

Standard clearance:

0.001 - 0.010 mm

- Carefully clean the seal housings.
- Measure the coupling clearance between the sealing rings and the piston grooves using suitable sensors, as shown in the diagram.
- If the clearance is greater than that indicated in the table, replace the piston.

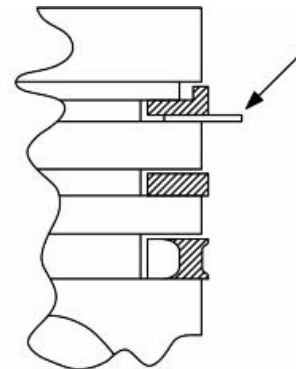

N.B.

MEASURE THE CLEARANCE BY INSERTING THE BLADE OF THE FEELER THICKNESS GAUGE FROM THE SECOND SEAL SIDE.

Fitting clearance

1st compression ring - standard coupling clearance 0.015 - 0.06 mm **1st compression ring - maximum clearance allowed after use** 0.07 mm
2nd compression ring - standard coupling clearance 0.015 - 0.06 mm **2nd compression ring - maximum clearance allowed after use** 0.07 mm
oil scraper ring - standard coupling clearance 0.015 - 0.06 mm **oil scraper ring - maximum clearance allowed after use** 0.07 mm

- Check that the head coupling surface is not worn or misshapen.
- Pistons and cylinders are classified according to diameter. The coupling is carried out in pairs (M-M, N-N, O-O, P-P).



Characteristic

Maximum allowable run-out:

0.001 in 0.05 mm

Piston rings

Sealing rings

- Alternately insert the three sealing rings into the cylinder, in the area where it retains its original diameter. Using the piston, insert the rings perpendicularly to the cylinder axis.
- Measure the opening (see figure) of the sealing rings using a feeler gauge.
- Replace the piston rings if values higher than those prescribed are measured.

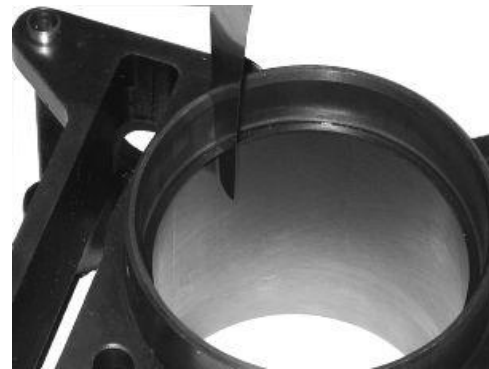

N.B.

BEFORE REPLACING ONLY THE PISTON RINGS, MAKE SURE THAT COUPLING CLEARANCE BETWEEN THE SEAL RINGS AND ITS GROOVES, AND THAT BETWEEN THE PISTON AND THE CYLINDER ARE AS SPECIFIED. IN ANY CASE, NEW PISTON SEALING RINGS USED IN COMBINATION WITH A USED CYLINDER MAY HAVE DIFFERENT BEDDING CONDITIONS THAN THE STANDARD ONES.

Characteristic

Top piston ring

Standard opening: 0.15 to 0.30 mm

Middle piston ring

Standard opening: 0.20 - 0.40 mm

scraper ring

Standard opening: 0.20 - 0.40 mm

Crankcase - crankshaft - connecting rod

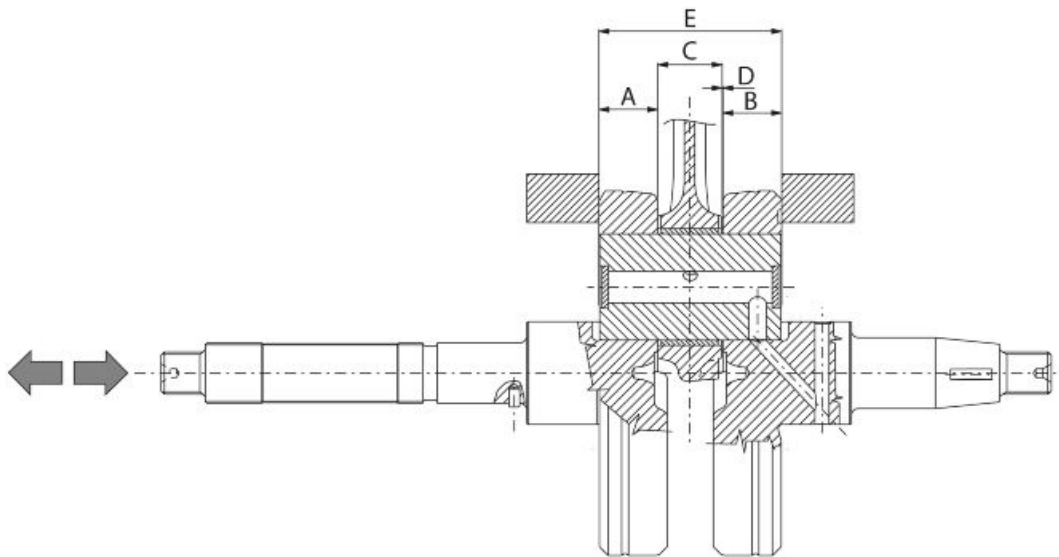

AXIAL CLEARANCE BETWEEN CRANKSHAFT AND CONNECTING ROD

Name	Description	Dimensions	Initials	Quantity
Transmissionside half-shaft		16.6 +0-0.05	A	D = 0.20 - 0.50
Flywheel-side halfshaft		16.6 +0-0.05	B	D = 0.20 - 0.50
Connecting rod		18 -0.10 -0.15	C	D = 0.20 - 0.50
Spacer tool		51.4 +0.05	E	D = 0.20 - 0.50

Diameter of crankshaft bearings.

Measure the bearings on both axes x-y.

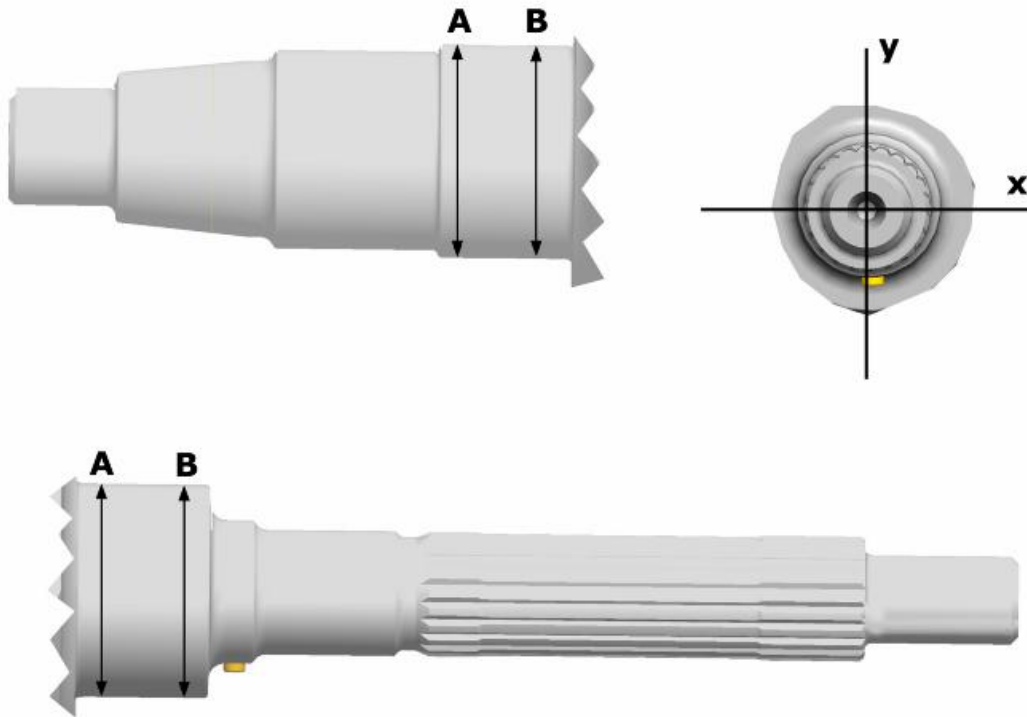

CRANKSHAFT

Specification	Desc./Quantity
Crankshaft bearings: Standard diameter: Cat. 1	28.998 ÷ 29.004 mm
Crankshaft bearings: Standard diameter: Cat. 2	29.004 ÷ 29.010 mm

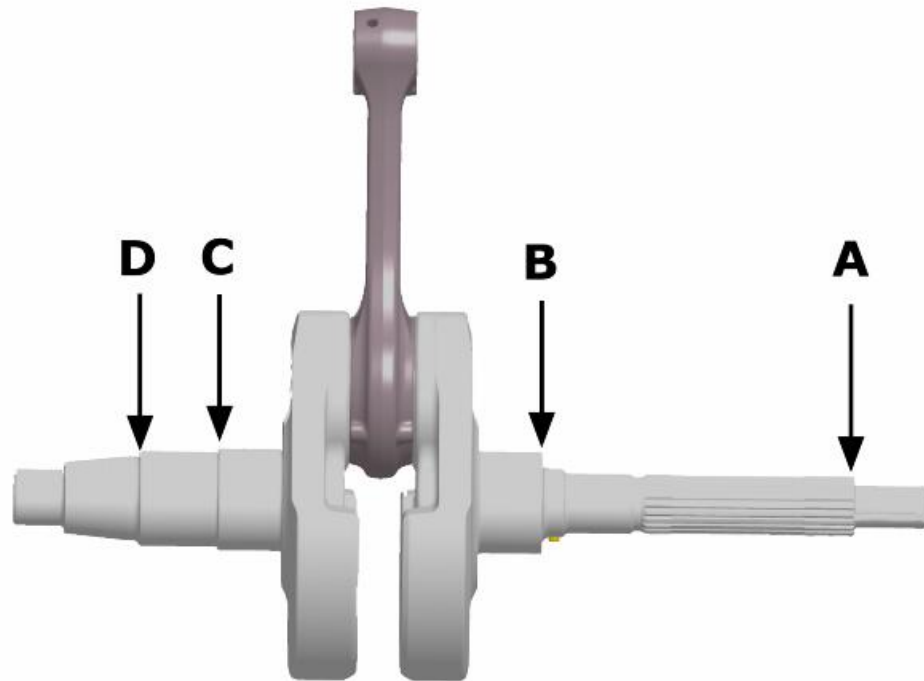

MAX. ADMISSIBLE DISPLACEMENT

Specification	Desc./Quantity
A =	0.15 mm
B =	0.010 mm
C =	0.010 mm
D =	0.10 mm

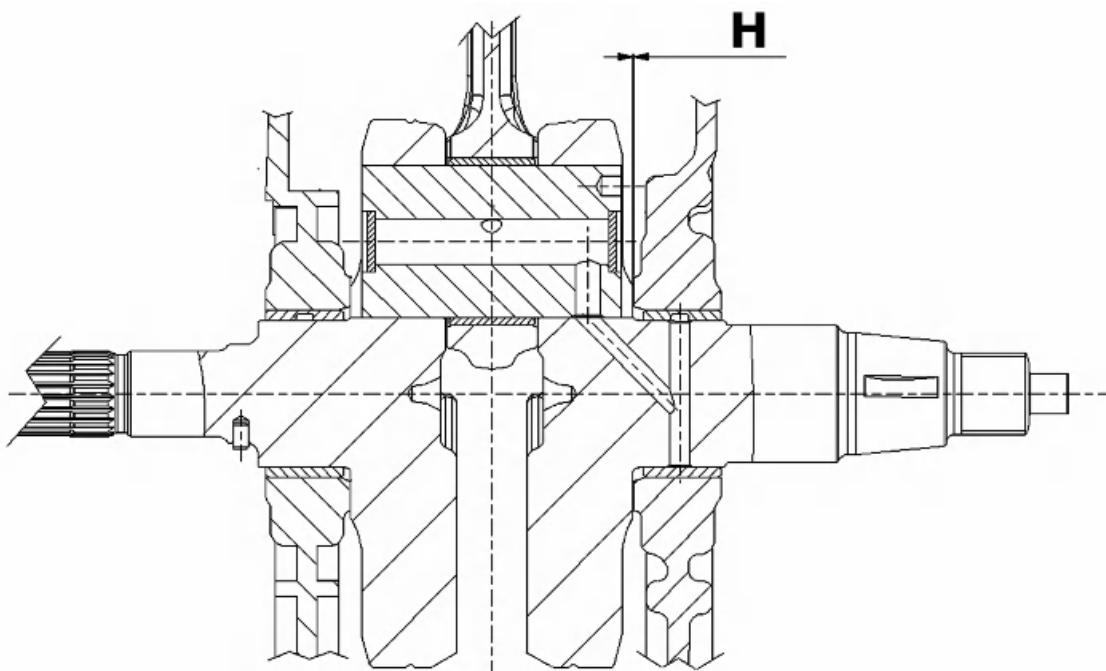

Characteristic

Crankshaft-crankcase axial clearance (H)

0.15 ÷ 0.43 mm

- Using a bore gauge, measure the connecting rod small end diameter.

N.B.

IF THE CONNECTING ROD SMALL END DIAMETER EXCEEDS THE STANDARD DIAMETER, EXHIBITS WEAR OR OVERHEATING, PROCEED TO REPLACE THE CRANKSHAFT AS DESCRIBED IN THE CRANKCASE AND CRANKSHAFT CHAPTER.



Characteristic

Standard diameter

16 +0.025 +0.015 mm

- To obtain a good bushing lubrication it is necessary to have both an optimal lubricating pressure and a good oil flow rate; the bushings must be correctly positioned so as not to obstruct the oil supply channels.
- The main bushings are comprised of two half-bearings, one with holes and channels for lubrication whereas the other is solid.
- The solid half-bearing is intended to stand the thrusts caused by combustion, and for this reason it is arranged opposite the cylinder.
- To prevent shutters in the oil feeding channels, the matching surface of the two half-bearings must be perfectly orthogonal to the cylinder axis, as shown in the figure.
- The oil feeding channel section is also affected by the bushings driving depth compared with the crankshaft axial clearance of the limiting surface.
- Check the inside diameter of the main bushings in the three directions indicated in the diagram.
- Repeat the measurements for the other bushing half. see diagram.
- There are three crankcase versions: with BLUE, YELLOW or GREEN bushings.
- There is only one type of main bushing housing hole in the crankcase. The standard bushing diameter after driving is variable on the basis of a coupling selection.
- There are 2 categories of bushing seats in the crankcase - Cat 1 and Cat 2 - just like those for the crankshaft.
- The main bushings are subdivided into 3 categories according to thickness; see table below:

BEARINGS

TYPE	IDENTIFICATION	CRANKSHAFT HALF-BEARING
B	BLUE	1.973 - 1.976
C	YELLOW	1.976 - 1.979
E	GREEN	1.979 - 1.982

COUPLINGS

BUSHING CATEGORY	CRANKCASE HALVES CATEGORY	BUSHING INSIDE DIAMETER AFTER FITTING
B	2	29.024 ÷ 29.054

BUSHING CATEGORY	CRANKCASE HALVES CATEGORY	BUSHING INSIDE DIAMETER AFTER FITTING
C	1	29.024 ÷ 29.054
	2	29.018 ÷ 29.048
E	1	29.018 ÷ 29.048

Combine the crankshaft with two crankwebs category 1 with a crankcase category 1 (or cat. 2 with cat. 2) A spare crankcase cannot be combined with a crankshaft with mixed categories. The spare crankshaft has half-shafts of the same category.

CATEGORIES

CRANKCASE HALVES	ENGINE HALF-SHAFT	BUSHING
Cat. 1	Cat. 1	E
Cat. 2	Cat. 2	B
Cat. 1	Cat. 2	C
Cat. 2	Cat. 1	C

N.B.

DO NOT TAKE THE MEASUREMENT ON THE TWO HALF-SHELL COUPLING SURFACE SINCE THE ENDS ARE RELIEVED TO ALLOW BENDING DURING THE DRIVING OPERATION.

N.B.

SPARE CRANKCASES ARE SELECTED WITH CRANKCASE HALVES OF THE SAME CATEGORY AND ARE FITTED WITH CATEGORY C (YELLOW) BUSHINGS

Characteristic

Crankshaft-bushing maximum clearance admitted:

0.08 mm

Diameter of crankcase without bushing

CAT 1: 32.959 - 32.965 mm

CAT 2: 32.953 - 32.959 mm

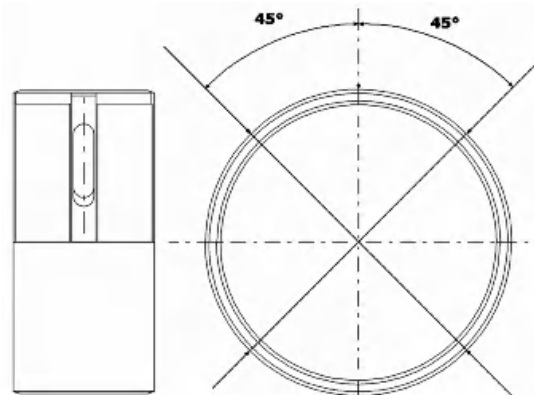

Cylinder Head

Before performing head service operations, thoroughly clean all coupling surfaces. Note the position of the springs and the valves so as not to change the original position during refitting

- Using a trued bar and a feeler gauge, check that the cylinder head surface is not worn or distorted.

Characteristic

Maximum allowable run-out:

0.1 mm



- In case of faults, replace the head.
- Check the sealing surfaces for the intake and exhaust manifold.
- Check that the camshaft and the rocker pin capacities exhibit no wear.

- Check that the head cover shows no signs of wear.
- Check that the coolant seal plug exhibits no oxidation.

- Insert the valves into the cylinder head.
- Alternatively check the intake and exhaust valves.
- The test is carried out by filling the manifold with petrol and checking that the head does not ooze through the valves when these are just pressed with the fingers.

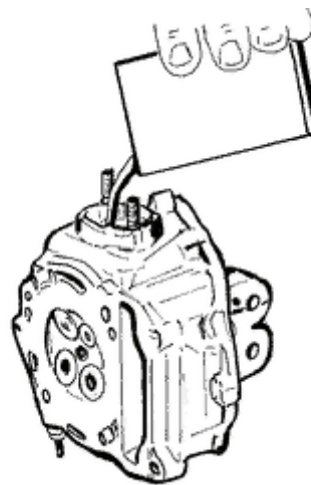

Measure the camshaft bearing seats and rocking lever support pins with a bore meter

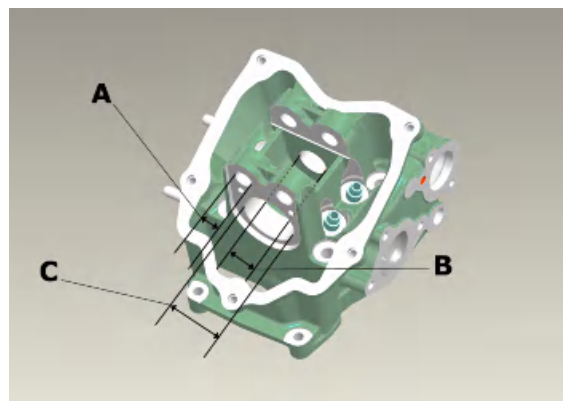

HEAD BEARINGS

Specification	Desc./Quantity
bearing «A»	Ø 12.000 - 12.018
bearing «B»	Ø 20.000 - 20.021
bearing «C»	Ø 37.000 - 37.025

Measure the unloaded spring length

Characteristic Standard length

40.2 mm

Allowable limit after use:

38.2 mm

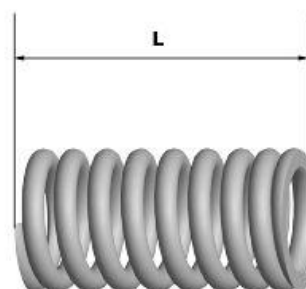

- Clean the valve seats of any carbon residues.
- Using the Prussian blue, check the width of the impression on the valve seat "V".

Characteristic

Standard value:

1 - 1.3 mm

Limit allowed:

1.6 mm

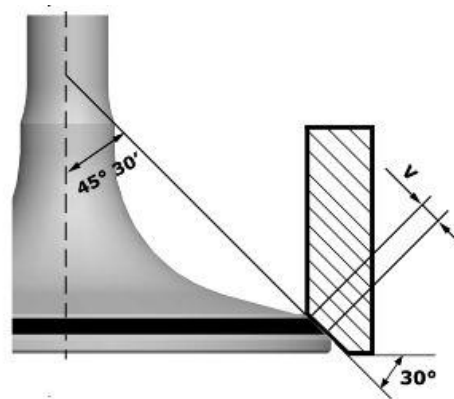

- If the impression width on the valve seat is larger than the prescribed limits, true the seats with a 45° mill and then grind.
- In case of excessive wear or damage, replace the head.

STANDARD VALVE LENGTH

Specification	Desc./Quantity
Valve check: Standard length	Intake: 94.6 mm
Valve check: Standard length	Exhaust: 94.4 mm

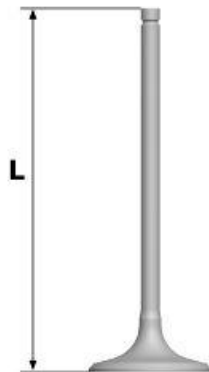

- Measure the diameter of the valve stems in the three positions indicated in the diagram.

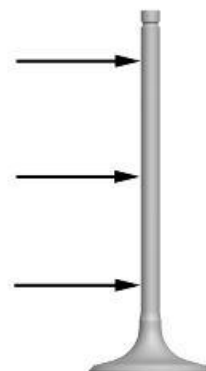

STANDARD DIAMETER

Specification	Desc./Quantity
Intake:	4.987 - 4.972 mm
Exhaust:	4.975 - 4.960 mm

MINIMUM DIAMETER PERMITTED

Specification	Desc./Quantity
Intake:	4.96 mm
Exhaust:	4.945 mm

- Calculate the clearance between the valve and the valve guide.

- Check the deviation of the valve stem by resting it on a «V» shaped abutment and measuring the extent of the deformation with a dial gauge.

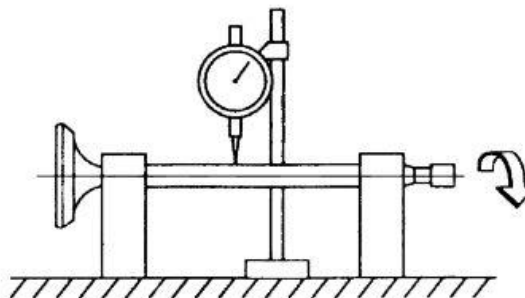

Characteristic

Limit value admitted:

0.1 mm

- Check the concentricity of the valve head by placing a dial gauge at right angles to the valve head and rotating it on the «V» shaped support.

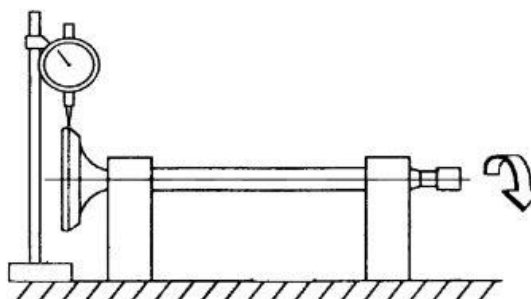

Characteristic

Limit allowed:

0.03 mm

Measure the valve guide.

Characteristic

Valve guide:

5 +0.012 mm

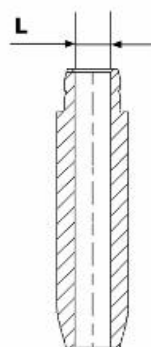

- After measuring the valve guide diameter and the valve stem diameter, check clearance between guide and stem.



INTAKE

Specification	Desc./Quantity
Standard clearance:	0.013 - 0.04 mm
Limit allowed:	0.08 mm

EXHAUST

Specification	Desc./Quantity
Standard clearance:	0.025 - 0.052 mm
Limit allowed:	0.09 mm

- Check that there are no signs of wear on the mating surface with the set screw articulated terminal.

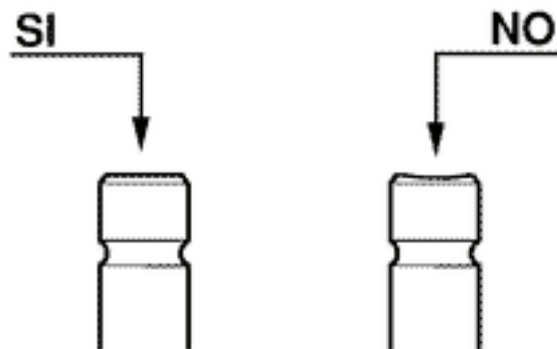

- If no anomalies are found during the above checks, you can use the same valves. To obtain better sealing performance, grind the valve seats. Grind the valves gently with a fine-grained lapping compound. During the grinding, keep the cylinder head with the valve axes in a horizontal position. This will prevent the lapping compound residues from penetrating between the valve stem and the guide (see figure).



CAUTION

TO AVOID SCORING THE MATING SURFACE, DO NOT ROTATE THE VALVE WHEN NO LAPPING COMPOUND IS LEFT. CAREFULLY WASH THE CYLINDER HEAD AND THE VALVES WITH A SUITABLE PRODUCT FOR THE TYPE OF LAPPING COMPOUND BEING USED.

CAUTION

DO NOT REVERSE THE FITTING POSITIONS OF THE VALVES (RIGHT - LEFT).

- Check that the camshaft bearings exhibit no scores or abnormal wear.
- Using a micrometer, measure the camshaft bearings.

STANDARD DIAMETER

Specification	Desc./Quantity
Camshaft check: Standard diameter	Bearing A Ø: 36.95 - 36.975 mm
Camshaft check: Standard diameter	Bearing B diameter: 19.959 - 19.98 mm

MINIMUM DIAMETER PERMITTED

Specification	Desc./Quantity
Camshaft check: Minimum diameter permitted	Bearing A Ø: 36.94 mm
Camshaft check: Minimum diameter permitted	Bearing B diameter: 19.950 mm

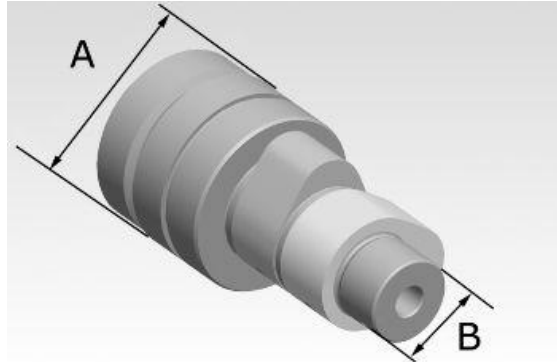

-Using a gauge, measure the cam height.

STANDARD HEIGHT

Specification	Desc./Quantity
Camshaft check: Standard height	Intake: 30.285 mm
Camshaft check: Standard height	Exhaust: 29.209 mm

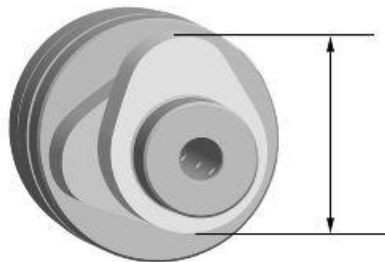

Check the axial clearance of the camshaft

CAMSHAFT AXIAL CLEARANCE

Specification	Desc./Quantity
Camshaft check: Standard axial clearance:	0.11 - 0.41 mm
Camshaft check: Maximum admissible axial clearance:	0.42 mm

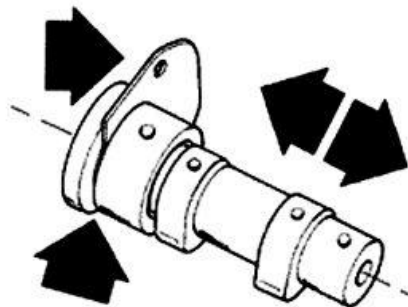

- Measure the external diameter of the rocking lever pins
- Check the rocker pins do not show signs of wear or scoring.

- Measure the internal diameter of each rocker

Check there are no signs of wear on the pad from contact with the cam and on the jointed adjustment plate.

DIAMETER OF PINS AND ROCKING LEVERS

Specification	Desc./Quantity
Rocking lever inside diameter: Standard diameter	Ø 12.000 - 12.011 mm
Rocking lever pin diameter: Standard diameter	Ø 11.977 - 11.985 mm



CLASSIFICATION OF DECOMPRESSION PIN/SCREW KNOB - CAMSHAFT

Decompression pin/screw knob

- Class identification sign: A - B - C
- Stamp of the class identification sign: pin end on screw knob side



Camshaft

- Class identification sign: A - B - C
- Stamp of the class identification sign: camshaft - sprocket timing view



CLASS MATCHING

	Decompression screw knob (pin) - Class A	Decompression screw knob (pin) - Class B	Decompression screw knob (pin) - Class C
Camshaft - Class A	A - A	NO	NO
Camshaft - Class B	NO	B - B	NO
Camshaft - Class C	NO	NO	C - C

Check the combustion chamber's pressure during the ignition so that it ranges between the accepted values listed below and also check the engine's revolutions.

Perform the check when the battery is loaded, at room temperature and use a pressure gauge to detect the (relative) pressure during the ignition and the corresponding engine revolutions.

PRESSURE CHECK IN THE COMBUSTION CHAMBER DURING IGNITION

	Engine speed (RPM)	Relative pressure (bar)
MIN	400	4,5
MAX	600	8,0





INDEX OF TOPICS

TOOLING



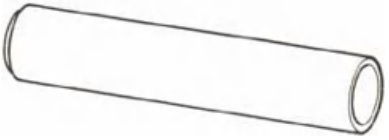

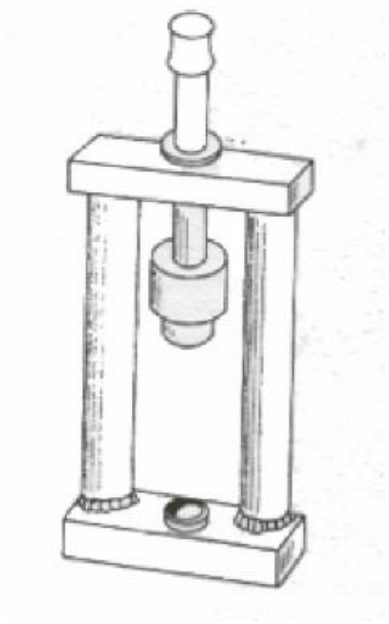

TOOL



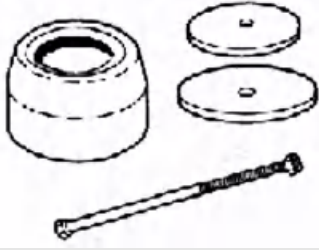

SPECIFIC TOOLS

Stores code	Description	
001330Y	Tool for fitting steering seats	
001467Y017	Bell for bearings, OD 39 mm	
001467Y014	Calliper to extract ø 15-mm bearings	
001467Y035	Bearing housing, external ø 47 mm	
001467Y013	Calliper to extract ø 15-mm bearings	
005095Y	Engine support	







Stores code	Description	
002465Y	Calliper for circlips	
006029Y	Punch for fitting steering bearing on the steering tube	
020004Y	Punch for removing steering bearings from headstock	
020021Y	Front suspension service tool	
020036Y	Punch	
020038Y	Punch	

Stores code	Description	
020055Y	Wrench for steering tube ring nut	
020074Y	Support base for checking crankshaft alignment	
020115Y	punch ø 18	
020150Y	Air heater mounting	
020151Y	Air heater	
020193Y	Oil pressure gauge	

Stores code	Description	
020244Y	punch ø 15	
020262Y	Crankcase splitting plate	
020271Y	Tool for removing-fitting silent bloc	
020263Y	Driven pulley assembly sheath	
020306Y	Punch valve seal rings fitting	
020329Y	Mity-Vac vacuum pump	

Stores code	Description	
020330Y	Stroboscopic light to check timing	
020331Y	Digital multimeter	
020332Y	Digital rpm indicator	
020335Y	Magnetic mounting for dial gauge	

Stores code	Description	
020357Y	32 x 35-mm Adaptor	
020359Y	42 x 47 mm Adaptor	
020360Y	52 x 55 mm adaptor	
020363Y	20-mm guide	
020364Y	25-mm guide	
020365Y	22 mm guide	

Stores code	Description	
020375Y	28 x 30 mm adaptor	
020376Y	Adaptor handle	
020382Y	Valve cotters equipped with part 012 removal tool	
020382Y011	adapter for valve removal tool	
020393Y	Piston fitting ring	
020412Y	15-mm guide	

Stores code	Description	
020423Y	Driven pulley lock wrench	

020424Y	Driven pulley roller casing fitting punch	
---------	---	---







020426Y	Piston fitting fork	
---------	---------------------	--

020428Y	Piston position check mounting	
---------	--------------------------------	---

020431Y	Valve oil seal extractor	
---------	--------------------------	---

020434Y	Union for oil pressure measurement	
---------	------------------------------------	---

Stores code	Description	
020441Y	26 x 28 mm adaptor	
020444Y	Tool for installing/removing clutch on/ from driven pulley	
020454Y	Tool for fitting the pin snap rings (200 - 250)	
020456Y	Ø 24 mm adaptor	
020467Y	Flywheel extractor	
020477Y	Adapter 37 mm	

Stores code	Description	
020480Y	Fuel pressure measurement kit	 A fuel pressure measurement kit consisting of a circular gauge with a needle, connected to two flexible black hoses by a central metal fitting.
020483Y	30-mm guide	 A cylindrical metal guide with a threaded hole in the center, used for precise alignment during assembly.
020489Y	Hub cover support stud bolt kit	 A set of five identical metal stud bolts, each with a hexagonal base and a threaded top section.
020621Y	A.T cable pick-up adapter	 An electrical adapter for an automatic transmission (A.T) cable, featuring a black plastic housing and a coiled black cable with a connector.
020622Y	Transmission-side oil seal punch	 A set of tools for installing an oil seal, including a large metal punch, a smaller metal punch, a nut, and a bolt.
020627Y	Flywheel lock tool	 A flywheel lock tool consisting of a large metal ring with a handle and a smaller cylindrical component, used to lock the flywheel during maintenance.

Stores code	Description	
020648Y	Single battery charger	 A black rectangular battery charger with a control panel on the front featuring several knobs and a digital display. The top of the device has the text "BatteryMate 150-9" and "INTELLIMATE".
020922Y	Diagnosis Tool	 A black handheld electronic device with a blue screen displaying the word "PADS" and some technical information. It has a small lens or sensor at the bottom.
021021Y	Drive pulley lock	 A black plastic bracket with a central circular hole and four mounting points. Below the bracket are three screws and three washers.

INDEX OF TOPICS

MAINTENANCE

MAIN

FOR SUPERTECH VERSION**MAINTENANCE ICON**

This function indicates the scheduled maintenance interventions. For each time the key is turned to "ON", once the instrument panel has performed the initial check, if the value of the remaining kilometres until the next intervention is less than 300 Km (186.41 mi), the indicated icon will flash for 5 seconds. When the service mileage is reached, with each key "ON", the icon remains switched on steady until it is reset after the service operations are carried out.

**MAINTENANCE ICON RESET**

To reset the maintenance icon, proceed as follows:

- Turn the ignition switch to "ON";
- Briefly press the MODE joystick upward or downward until the "Battery charge state" function is displayed at the centre of the digital display.



N.B.



"PRESS BRIEFLY AND RELEASE": PRESS THE BUTTON AND RELEASE WITHIN 0.5 SECONDS;
 "PRESS AND HOLD": PRESS THE BUTTON AND HOLD FOR AT LEAST 2 SECONDS.

- Press and hold the MODE button for at least 10 seconds but not more than 15 seconds. Upon releasing it, the maintenance icon switches off. If the MODE joystick is released without waiting 10 seconds, the maintenance icon will not switch off and the service interval counter will not be reset.

CAUTION

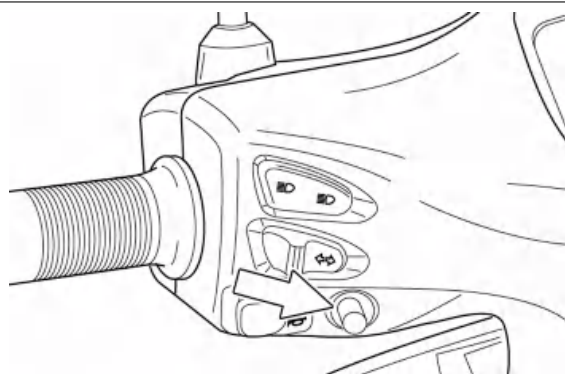

THE MAINTENANCE ICON RESET PROCEDURE MAY ONLY BE PERFORMED WHEN THE VEHICLE IS AT A STANDSTILL (SPEED = 0 Km/h).

**Maintenance chart****EUROPE VERSION**

SCHEDULED MAINTENANCE TABLE

I: CHECK AND CLEAN, ADJUST, LUBRICATE OR REPLACE IF NECESSARY.
 C: CLEAN, R: REPLACE, A: ADJUST, L: LUBRICATE.

km x 1,000	1	10	20	30	40	50	60	EVER Y 12 MONT HS	EVER Y 24 MONT HS
Safety blocks	I	I		I		I	I		
Spark plug			R		R		R		
Centre stand		L	L	L	L	L	L	L	L
Drive belt		R	R	R	R	R	R		
Throttle control	I	I	I	I	I	I	I	I	I
Complete roller housing		I	I	I	I	I	I		
Diagnosis by tool	I	I	I	I	I	I	I	I	I
Air filter		R	R	R	R	R	R		
CVT Filter		I	I	I	I	I	I		
Engine oil filter	R	R	R	R	R	R	R	R	R
Valve clearance		A	A	A	A	A	A		
Electrical system and battery	I	I	I	I	I	I	I		
Braking system	I	I	I	I	I	I	I	I	I
Coolant	I	I	I	I	I	I	I	I	R
Brake Fluid	I	I	I	I	I	I	I	I	R
Engine oil	R	R	R	R	R	R	R	R	R
Hub oil	R	I	R	I	R	I	R	I	I
Headlight direction adjustment		I	I	I	I	I	I		
Brake pads		I	I	I	I	I	I	I	I
Sliding shoes / CVT rollers		R	R	R	R	R	R		
Tire pressure and wear	I	I	I	I	I	I	I	I	I
Vehicle road test	I	I	I	I	I	I	I	I	I
Suspensions		I	I	I	I	I	I	I	I
Steering	A	A	A	A	A	A	A	I	I
Time required (minutes)	70	16 0	16 0	16 0	16 0	16 0	20 0	60	60

N.B.

AT EACH SCHEDULED MAINTENANCE MUST BE VERIFIED WITH THE DIAGNOSTIC TOOL IF THERE ARE ERRORS AND THE IF THE PARAMETERS ARE CORRECT. ENSURE THAT THE VEHICLE CALIBRATION IS UP TO DATE AFTER UPDATING THE DIAGNOSTIC TOOL.

CAUTION

AFTER THE SCHEDULED MAINTENANCE PROGRAM IS FINISHED YOU ARE TOLD TO PROCEED WITH THE MAINTENANCE OF THE VEHICLE STARTING FROM THE SERVICE COUPON OF 10,000 km (6,214 miles) OR 10 MONTHS.

FOR USA-LATAM VERSION

SCHEDULED MAINTENANCE TABLE

I: CHECK AND CLEAN, ADJUST, LUBRICATE OR REPLACE IF NECESSARY.
 C: CLEAN, R: REPLACE, A: ADJUST, L: LUBRICATE

mi (km) x 1.000	0.6 (1)	6.2 (10)	12.4 (20)	18.6 (30)	24.8 (40)	31 (50)	37.2 (60)	EVER Y 12 MONT HS	EVER Y 24 MONT HS
Safety blocks	I	I		I		I	I		
Spark plug			R		R		R		
Centre stand		L	L	L	L	L	L	L	L
Drive belt		R	R	R	R	R	R		
Throttle control	I	I	I	I	I	I	I	I	I
Complete roller housing		I	I	I	I	I	I		
Diagnosis by tool	I	I	I	I	I	I	I	I	I
Air filter		R	R	R	R	R	R		
CVT Filter		I	I	I	I	I	I		

mi (km) x 1.000	0.6 (1)	6.2 (10)	12.4 (20)	18.6 (30)	24.8 (40)	31 (50)	37.2 (60)	EVER Y 12 MONT HS	EVER Y 24 MONT HS
Engine oil filter	R	R	R	R	R	R	R	R	R
Valve clearance		A	A	A	A	A	A		
Electrical system and battery	I	I	I	I	I	I	I		
Braking system	I	I	I	I	I	I	I	I	I
Coolant	I	I	I	I	I	I	I	I	R
Brake Fluid	I	I	I	I	I	I	I	I	R
Engine oil	R	R	R	R	R	R	R	R	R
Hub oil	R	I	R	I	R	I	R	I	I
Headlight direction adjustment		I	I	I	I	I	I		
Brake pads		I	I	I	I	I	I	I	I
Sliding shoes / CVT rollers		R	R	R	R	R	R		
Tire pressure and wear	I	I	I	I	I	I	I	I	I
Vehicle road test	I	I	I	I	I	I	I	I	I
Suspensions		I	I	I	I	I	I	I	I
Steering	A	A	A	A	A	A	A	I	I
Time required (minutes)	70	160	160	160	160	160	200	60	60

N.B.

AT EACH SCHEDULED MAINTENANCE MUST BE VERIFIED WITH THE DIAGNOSTIC TOOL IF THERE ARE ERRORS AND THE IF THE PARAMETERS ARE CORRECT. ENSURE THAT THE VEHICLE CALIBRATION IS UP TO DATE AFTER UPDATING THE DIAGNOSTIC TOOL.

CAUTION

AFTER THE SCHEDULED MAINTENANCE PROGRAM IS FINISHED YOU ARE TOLD TO PROCEED WITH THE MAINTENANCE OF THE VEHICLE STARTING FROM THE SERVICE COUPON OF 10,000 km (6,214 miles) OR 10 MONTHS.

Recommended products

Piaggio Group recommends the use of products from its Castrol official partner for the scheduled maintenance of its vehicles.

Only use lubricants and fluids which meet or exceed the performance characteristics specified.

This also applies when topping up only.



TABLE OF RECOMMENDED PRODUCTS

Product	Description	Specifications
Engine oil 5W -40	Synthetic-based lubricant for four-stroke engines.	SAE 5W-40; JASO MA, MA2; API SL; ACEA A3
Transmission oil 80W-90	Lubricant for gearboxes and transmissions.	SAE 80W-90 API GL-4
Anti-freeze liquid, ready to use, colour red	Ethylene glycol antifreeze liquid with organic inhibition additives. Red, ready to use.	ASTM D 3306 - ASTM D 4656 - ASTM D 4985 - CUNA NC 956-16
DOT 4 brake fluid	Synthetic brake fluid.	SAE J 1703; FMVSS 116; ISO 4925; CUNA NC 956 DOT4
Water repellent spray grease	Water repellent pouring calcium spray grease.	White, soap base spray grease with NLGI 2 Calcium complex; ISO-L-XBCIB2

Checking the spark advance

The ignition advance is determined electronically on the basis of parameters known by the control unit. For this reason it is not possible to interpret the reference values based on the engine rpm. The ignition advance value is detectable at any time using the diagnostic tool. It is possible to check whether the ignition advance determined by the injection system matches the value actually activated on the engine, by means of the stroboscopic light.



Proceed as follows:

- Remove the spark plug.
- Remove the plastic cap from the flywheel cover.
- Remove the transmission compartment air intake cover.



- Rotate the drive pulley fan until the reference marks on the flywheel and the flywheel cover are aligned.



- Reposition the reference mark on the transmission side between the fan and the transmission cover.
- Refit the spark plug.
- Refit the plastic cap on the flywheel cover.



- Adjust the spark gap so that it is in the contact position (no notches visible).



- Install the spark gap on the engine between the spark plug and the spark plug hood.



- Connect the induction clamp on the spark gap cable respecting the proper polarity (the arrow on the clamp must be pointing at the spark plug).
- Connect the diagnostic tool, start the engine and select «parameters» from the menu.
- Set the stroboscopic light control to the traditional four-stroke engine position (1 spark, 2 revs).



- Check that the measured rpm and ignition advance values match those indicated by the diagnostic tool.



If the values do not match, check:

- the distribution timing.
- the engine speed sensor.
- the injection control unit.

Spark plug

Proceed as follows:

Lift the saddle and remove the helmet compartment.



Disconnect the spark-plug cap, detaching the H.V. cable from the safety bracket by rotating it clockwise.



Undo the spark plug using the specific spark plug spanner.

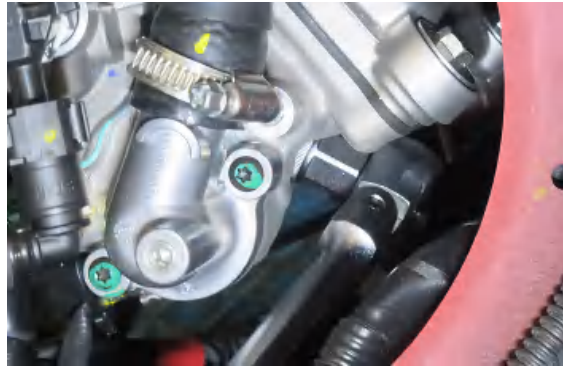

Remove the spark plug.

When refitting, place the spark plug into the hole at the required angle and finger tighten it as far as it will go. Use the wrench only to tighten it.

Insert the cap on the spark-plug, securing it to the safety bracket.

CAUTION



THE SPARK PLUGS MUST BE DISMANTLED WHEN THE ENGINE IS COLD. SPARK PLUG MAINTENANCE IS DESCRIBED IN THE SCHEDULED MAINTENANCE TABLE. THE USE OF NON-CONFORMING ELECTRONIC CONTROL UNITS AND ELECTRONIC IGNITIONS AND SPARK PLUGS OTHER THAN THOSE RECOMMENDED MAY SERIOUSLY DAMAGE THE ENGINE..

N.B.

USING SPARK PLUGS OTHER THAN THE INDICATED TYPE OR SHIELD-LESS SPARK PLUG CAPS CAN CAUSE ELECTRICAL SYSTEM FAILURES.

Hub oil

Check

- Rest the vehicle on its centre stand on level ground.
- Unscrew the oil dipstick, dry it with a clean cloth and reinsert it, **screwing it fully into place.**

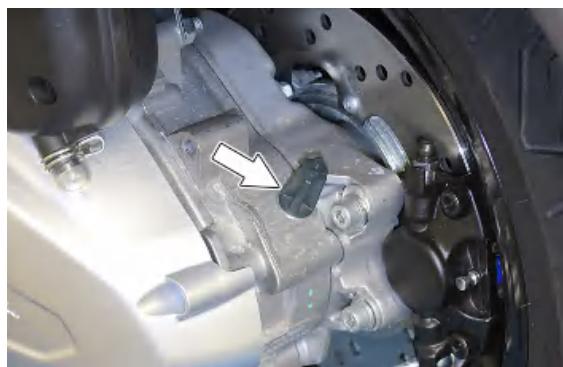

- Unscrew the dipstick and check that the oil level corresponds to the «MAX» mark as indicated in figure; if the level is below this mark, top-up the hub oil.

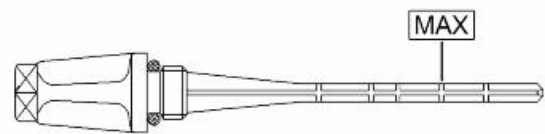

-Screw up the oil dipstick again and make sure it is locked properly into place.

Replacement

Rest the vehicle on its centre stand on level ground.

- Unscrew the hub oil dipstick.

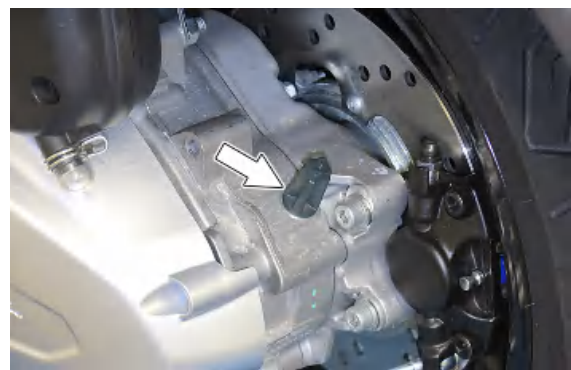

- Unscrew the drainage screw and drain all the oil into a suitable container.

- Tighten the drainage screw, applying the pre-defined torque, and refill the hub using the recommended product.



Air filter

Proceed as follows:

- Remove the left side fairing.



-
- Lift the saddle and remove the helmet compartment.



-
- Unscrew the knobs, which are accessible after removing the helmet compartment.

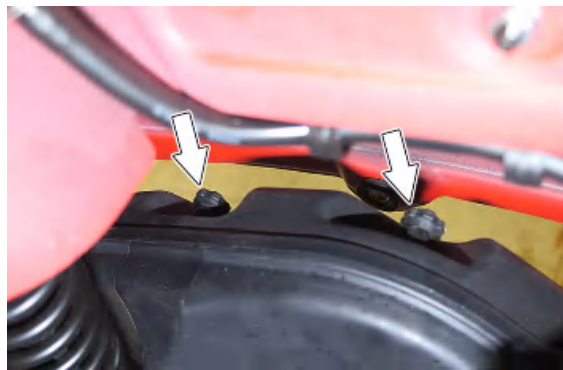

-
- Unscrew the air filter cover fastening screws.



-
- Remove the cover from the air filter.



- Replace the filter element.

CAUTION



REPLACE THE AIR FILTER IN ACCORDANCE WITH THE INSTRUCTIONS PROVIDED IN THE SCHEDULED MAINTENANCE TABLE. IN THE EVENT OF HEAVY DUTY USAGE, THE MAINTENANCE OPERATIONS MUST BE CARRIED OUT MORE FREQUENTLY ON THE VEHICLE, IN ORDER TO AVOID DAMAGING THE ENGINE.



Engine oil

In four-stroke engines, the engine oil is used to lubricate the timing elements, the bench bearings and the head-engine block-piston assembly. **An insufficient quantity of oil can cause serious damage to the engine.**

In all four stroke engines, the deterioration of the oil characteristics, or a certain consumption should be considered normal, especially if during the run-in period. Consumption levels in particular can be influenced by the conditions of use (e.g.: oil consumption increases when driving at "full throttle").

Replacement

Change the engine oil and replace the filter in accordance with the instructions provided in the scheduled maintenance table.

- Unscrew the dipstick so that the oil drains from the engine more efficiently.



- Unscrew the engine oil drainage cap «A» and remove the mesh filter, allow the oil to drain into a suitable container.

- Unscrew the engine oil filter «B».



- Check the condition of the o-rings on the drainage cap and the mesh filter.
- Lubricate the o-rings, insert the mesh filter in its housing and tighten the drainage cap, applying the pre-defined torque.



- Lubricate the engine oil filter o-ring and secure it in its housing, applying the pre-defined tightening torque.



- Restore the engine oil level using the recommended product.

Start the engine, leave it running for a few minutes and switch it off again. Check the level again after approximately five minutes and top up if necessary. Do not exceed the **MAX** level mark.

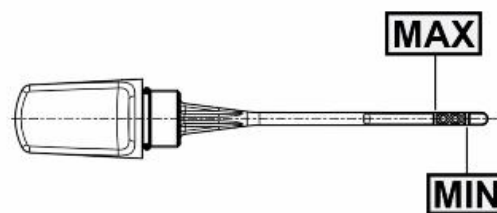

N.B.

THE ENGINE MUST BE HOT WHEN THE OIL IS CHANGED.

WARNING

USED OIL CONTAINS ENVIRONMENTALLY HARMFUL SUBSTANCES

Check

This check must be carried out when the engine is cold, if necessary, wait for 10 minutes after switching the engine off.

- Rest the vehicle on its centre stand on level ground.
- Unscrew the oil dipstick, dry it with a clean cloth and reinsert it, **screwing it fully into place.**



- Unscrew the dipstick and check that the oil level is between the «MIN» and «MAX» marks indicated in figure; if the level is below the «MIN» mark, top-up the engine oil, **taking care never to exceed the «MAX» level mark.**

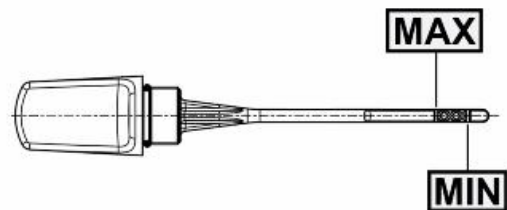

-Screw up the oil dipstick again and make sure it is locked properly into place.

Engine oil filter

The engine oil filter must be changed in accordance with the instructions provided in the scheduled maintenance table. Lubricate the o-ring before replacing the oil filter.



Oil pressure warning light

The vehicle is equipped with a tell-tale light on the instrument cluster that lights up when the key is turned to the «ON» position. This warning light will turn off when the engine comes on.

If the light turns on during braking, at idling speed or while turning a corner, it is necessary to check the oil level and the lubrication system.

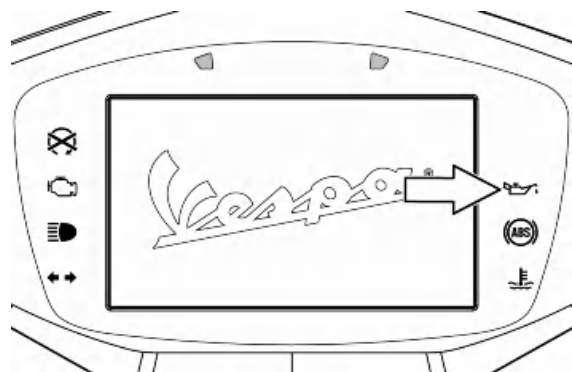
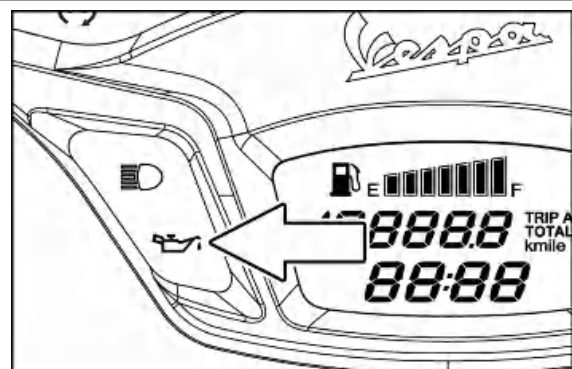

Checking the ignition timing

Proceed as follows:

- Lift the saddle and remove the helmet compartment.



- Unscrew the inspection cap on the flywheel side cover.

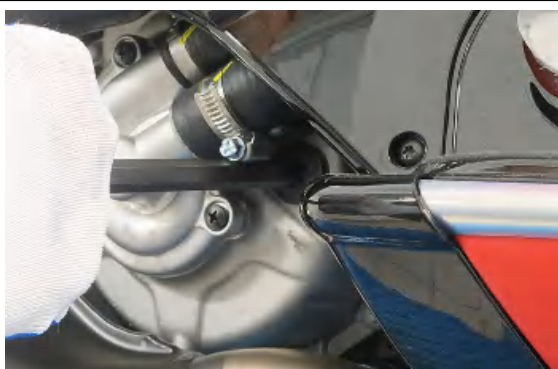

- Loosen the ignition spark plug and align the reference marks on the flywheel and the crankcase by rotating the crankshaft.



- Remove the big end cover.

Make sure that the 4V reference point on the camshaft control crown gear is aligned with the reference mark on the big end. If the reference is positioned diametrically opposite the reference mark on the big end, perform a complete rotation of the crankshaft.

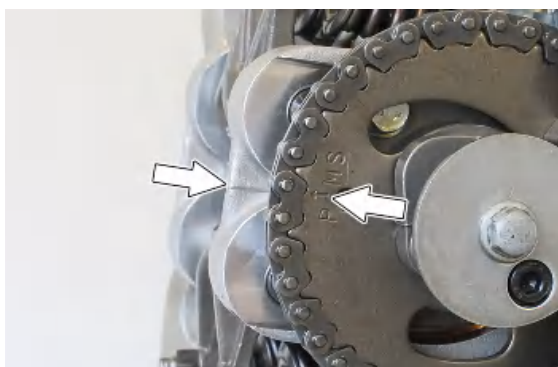

Checking the valve clearance

Checking the valve clearance should be carried out according to the scheduled maintenance table. Place the vehicle on the centre stand above a suitable lift so that the front wheel can be locked.

Disconnect the battery cables.

Remove the helmet compartment.

Remove the side fairings and the footrest terminals.

Remove the silencer.

Lift the rear of the body using a suitable device.



Remove the screws fixing the filter box to the engine.



Acting on the device, lift the body shell of the vehicle

Raise the stand from the floor and then lower the vehicle until the rear wheel touches the supporting surface.

Unscrew and remove the right shock absorber lower fixing nut.



Lift the filter box.

Unscrew and remove the lower fixing bolt of the left shock absorber.



Disconnect the spark plug tube.



Disconnect the throttle control transmissions



Unscrew the fuel pipe clamp fixing nut.

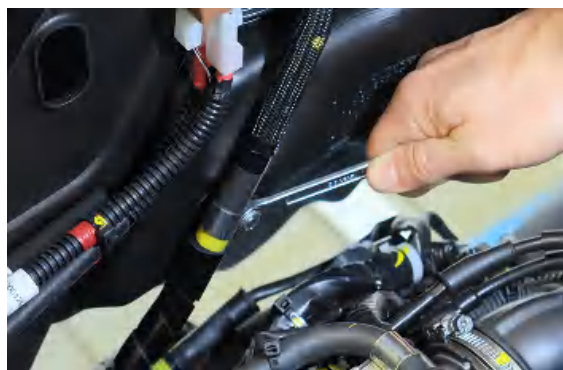

Unscrew and remove the transmission cover's fastening screws.



Remove the transmission cover.



Using the lifting device, lift the body of the vehicle, the engine rotates slightly between the rear wheel and the swingarm.

The big end raises making the taper cover accessible.

Undo and remove the screws that secure the taper cover.

Remove the tappet cover.



Act on the crankshaft to move the piston to the upper dead centre.



Verify the alignment of the reference on the big end with the one on the camshaft sprocket.

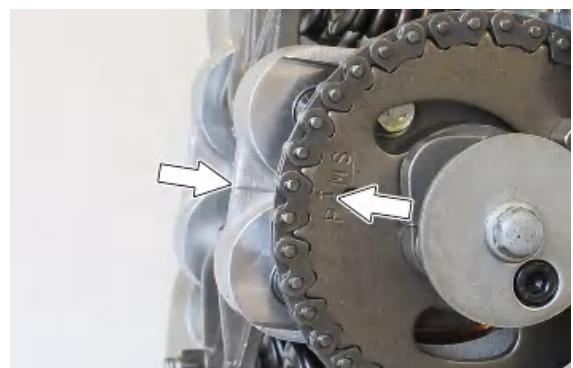

Using a feeler gauge, check the clearance between the adjuster and the valve.

Characteristic**Valve clearance (cold engine)**

Intake: 0.10 mm Exhaust: 0.15 mm

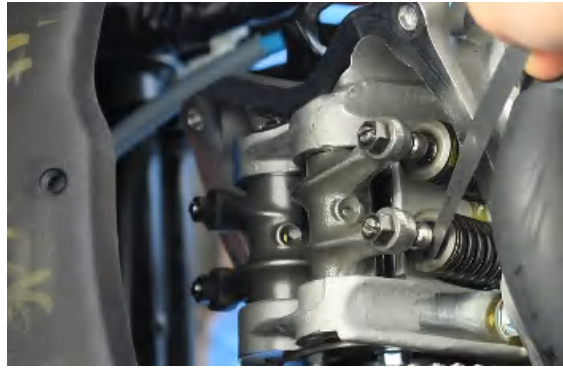

If an incorrect value is found, adjust it back to the prescribed value.



Fit the tappet cover.

Insert and tighten the fastening screws at the recommended torque.

Locking torques (N*m)

Tappet cover screws 6 - 7 Nm



Position the transmission cover.



Insert and tighten the fixing screws of the transmission cover to the prescribed torque.

Locking torques (N*m)

Transmission cover screws 11 - 13 Nm



Acting on the lifting device, lower the vehicle body to align the lower coupling of the shock absorber with the corresponding coupling on the engine. Insert and fasten the fixing bolt at the prescribed torque .

Locking torques (N*m)

Rear shock absorber - Engine 40 - 45 Nm



Insert the lower fixing bolt of the right shock absorber and tighten to the specified torque.

Locking torques (N*m)

Rear shock absorber - Silencer support bracket 40 - 45 Nm



Insert and tighten the fuel pipe clamp fixing nut.



Insert the throttle control cable in the support bracket.



Insert the spark plug tube



Position the air filter box.

Insert and tighten the screws fixing the filter box to the engine.



Using the lifting device, place the vehicle back on the centre stand.

Disconnect the lifting equipment .

Insert the helmet compartment.

fit the silencer.

Assemble the side fairings and the footrest terminals.

Connect the battery cables.



Cooling system

The coolant must be checked when the engine is cold, and in accordance with the indications provided in the scheduled maintenance table.

The engine cooling system is of the forced liquid circulation type.

With the engine running, if the engine temperature is too high, the relative indicator light on the instrument panel will turn on, indicating that the engine must be immediately shut off and allowed to cool. Inspect the cooling system

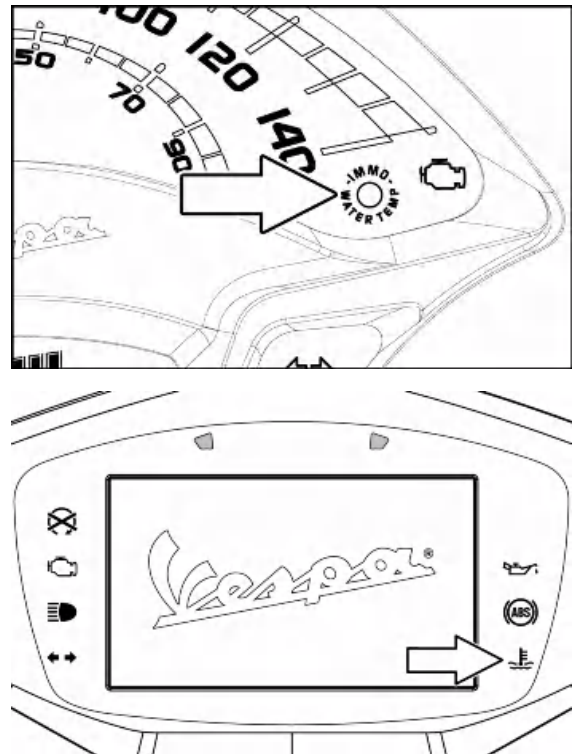

Level check

check the fluid when the engine is cold, according to the scheduled maintenance table, in the way shown below:

- Position the vehicle on the central stand.
- Unscrew the expansion chamber cover fastening screw.



- Top up with the recommended product when the fluid level is close to or under the "MIN" level. The fluid level should always be comprised between the "MIN" and "MAX." level.

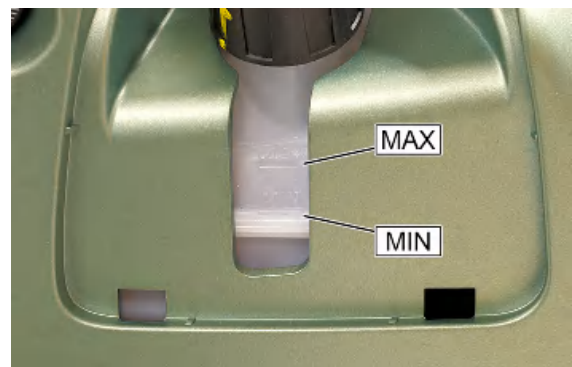

CAUTION
DO NOT EXCEED THE MAX. LEVEL WHEN FILLING SO AS TO AVOID THE COOLANT ESCAPING FROM THE EXPANSION TANK WHEN THE VEHICLE IS IN USE.

WARNING



YOU MUST MAKE SURE THE FLUID NEVER EXCEEDS THE MAXIMUM LEVEL INDICATED SO AS TO AVOID IT

**OVERFLOWING AND CAUSING DAMAGE WHILE THE SCOOTER IS MOVING.
TO ENSURE CORRECT ENGINE OPERATION, KEEP THE RADIATOR GRILLE CLEAN.**

WARNING



TO AVOID THE RISK OF SCALDING, DO NOT UNSCREW THE EXPANSION TANK COVER WHILE THE ENGINE IS STILL HOT.

Recommended products

Anti-freeze liquid, ready to use, colour red Ethylene glycol antifreeze liquid with organic inhibition additives. Red, ready to use.

ASTM D 3306 - ASTM D 4656 - ASTM D 4985 -
CUNA NC 956-16

Top-up

If necessary, top the cooling system up, with the engine cold, if you find the liquid is too close to the minimum level. If it becomes necessary to top-up the coolant level at frequent intervals, or you find that the expansion chamber is completely dry, check the cooling system to find the cause of the problem. Replace the coolant, using the recommended product, in accordance with the instructions provided in the scheduled maintenance table. For instructions on how to drain the system, refer to the dedicated section of the chapter covering the «**Cooling System**».

WARNING



TO AVOID THE RISK OF SCALDING, DO NOT UNSCREW THE EXPANSION TANK COVER WHILE THE ENGINE IS STILL HOT.

WARNING



**TO PREVENT AVOID HARMFUL FLUID LEAKAGE WHILE RIDING, ENSURE THAT THE LEVEL NEVER EXCEEDS THE MAXIMUM VALUE.
TO ENSURE CORRECT ENGINE OPERATION, KEEP THE RADIATOR GRILLE CLEAN.**

Braking system

Level check

Rest the vehicle on its centre stand and with the handlebars perfectly horizontal.

Check the liquid level through the relative inspection sight glass.

If the sight glass is full, the brake fluid level is correct. If the brake fluid is near the «MIN» reference, top-up



Top-up

Remove the front centre cover.

Remove the front handlebar cover.

Remove the fixing screws of the cover of the brake pumps and top-up with the recommended product.

CAUTION

ONLY USE DOT 4-CLASSIFIED BRAKE FLUID.

CAUTION



AVOID CONTACT OF BRAKE FLUID WITH EYES, SKIN, AND CLOTHING. IN CASE OF ACCIDENTAL CONTACT, RINSE WITH WATER.

CAUTION

BRAKE CIRCUIT FLUID IS HIGHLY CORROSIVE: DO NOT LET IT COME INTO CONTACT WITH PAINTED PARTS.

CAUTION

BRAKE FLUID IS HYGROSCOPIC; THAT IS, IT ABSORBS MOISTURE FROM THE SURROUNDING AIR. IF THE CONTENT OF MOISTURE IN THE BRAKE FLUID EXCEEDS A CERTAIN VALUE, BRAKING WILL BE INEFFICIENT. NEVER USE BRAKE LIQUID FROM OPEN OR PARTIALLY USED CONTAINERS.

UNDER NORMAL CLIMATIC CONDITIONS, REPLACE FLUID AS INDICATED IN THE SCHEDULED MAINTENANCE TABLE.

N.B.

SEE THE BRAKING SYSTEM CHAPTER WITH REGARD TO THE CHANGING OF BRAKE FLUID AND THE BLEEDING OF AIR FROM THE CIRCUITS.

Recommended products

DOT 4 brake fluid Synthetic brake fluid.

SAE J 1703; FMVSS 116; ISO 4925; CUNA NC 956 DOT4

Locking torques (N*m)

Brake pump reservoir screws 15 - 20



Headlight adjustment

Proceed as follows:

Position the vehicle in running order and with the tyres inflated to the prescribed pressure, onto a flat surface 10 m away from a half-lit white screen; ensure that the longitudinal axis of the vehicle is perpendicular to the screen;

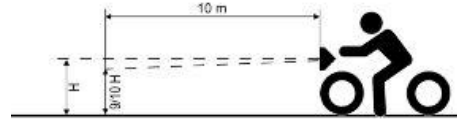

Turn on the headlight and check that the boundary of the light beam projected onto the screen is not higher than $9/10$ or lower than $7/10$ of the distance between the centre of the headlight and the ground;

If this is not the case, adjust the headlight by following the procedure below.

Turn the handlebar completely to the right.

Insert a screwdriver with a PH2 bit in the hole in the bottom part of the front handlebar cover.



Use the screwdriver to adjust:

Turn clockwise to raise the light beam and turn anticlockwise to lower the light beam.

Remove the screwdriver and move the handlebar to the centre.

Check the height of the light beam and, if necessary, repeat the procedure until it is correctly adjusted.



INDEX OF TOPICS

ELECTRICAL SYSTEM

ELE SYS

Components arrangement



1. ABS control unit: Remove the leg shield back plate to reach it.



2. Immobilizer antenna: Remove the leg shield back plate to reach it.



3. Electronic injection control unit: To access remove the helmet compartment.

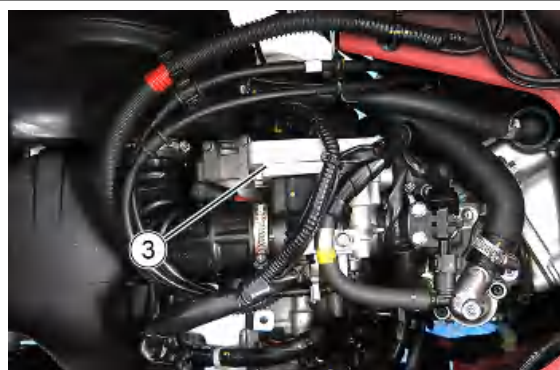

4. Diagnostics connector: To access remove the helmet compartment.



5. H.V. coil: Located above the transmission cover, remove the battery to gain access to it.

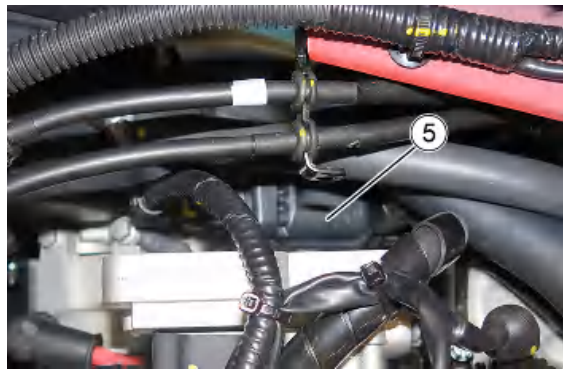

6. relays: Remove the central front cover to reach them.

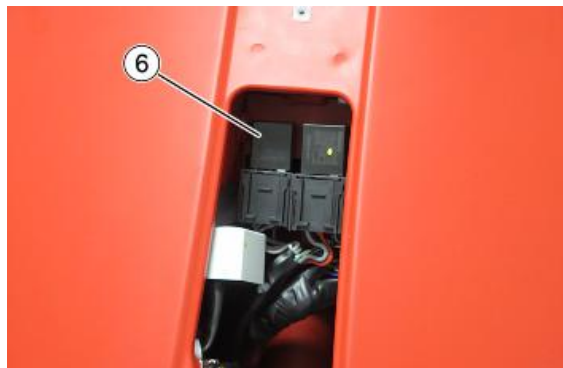

7. Horn: Remove the central front cover to reach them.



8. Starter relay: To access remove the helmet compartment.



9. Fuses: Open the top box to reach them



10. Voltage regulator: to access remove the battery.



11. Magneto flywheel connector: remove the footrest to reach it.



12. Pick-up connector: remove the footrest to reach it.



13. Roll-over sensor: Remove the footrest to reach it.

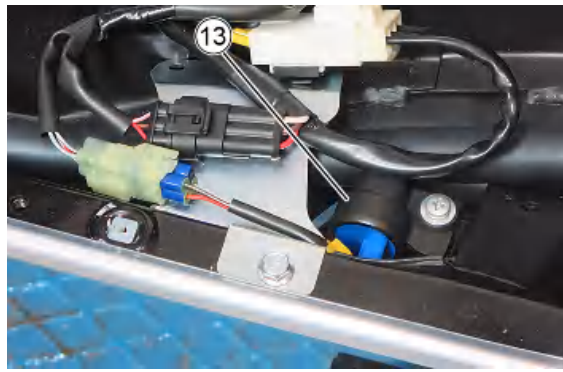

14. Ignition switch contacts: Remove the leg shield back plate to reach it.



15. fuel level sensor: To access remove the helmet compartment.



16. Coolant temperature sensor: To access remove the helmet compartment.

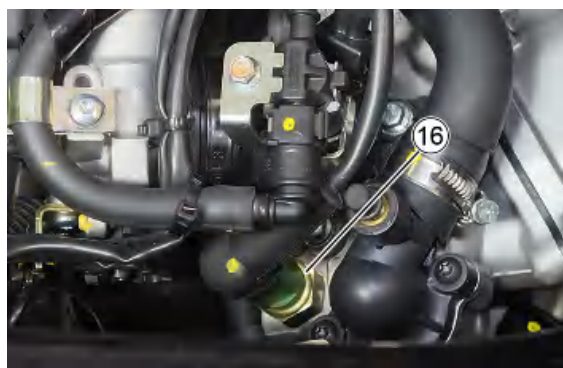

17. Direction indicator device: Remove the leg shield back plate to reach it.



18. front phonic wheel sensor connector: Remove the leg shield back plate to reach it.

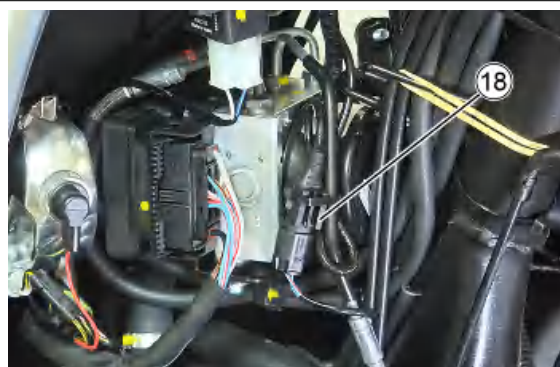

19. Front left turn signal and daylight running light connector: Remove the leg shield back plate to reach it.

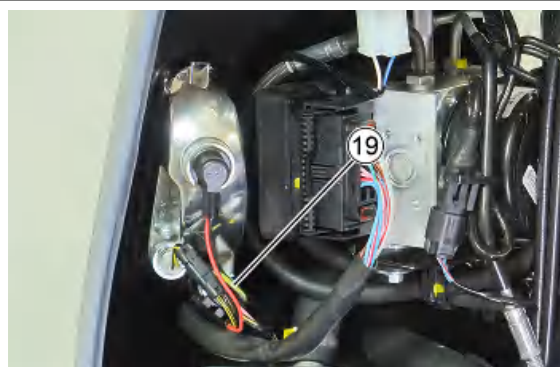

20. Front right turn signal and daylight running light connector: Remove the leg shield back plate to reach it.

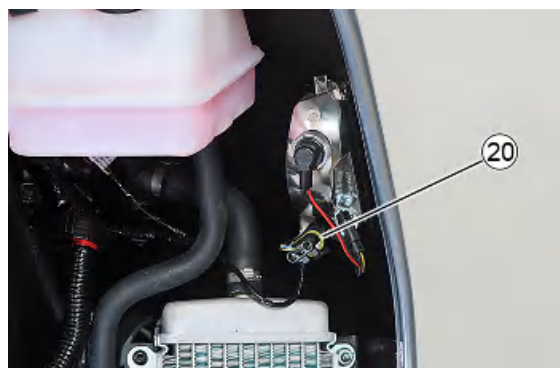

21. Fuel pump: To access remove the helmet compartment.

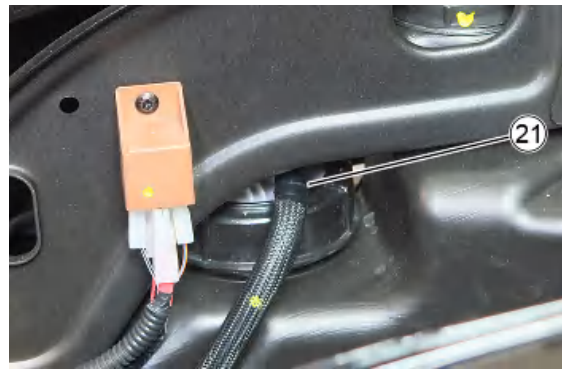

22. rear phonic wheel sensor connector: To access remove the helmet compartment.

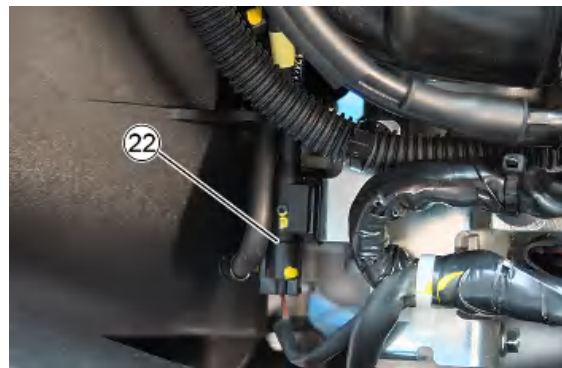

23. Injector: To access remove the helmet compartment.

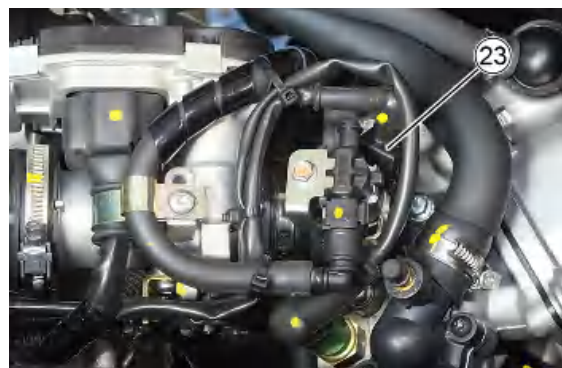

24. Bike finder device: Remove the leg shield back plate to reach it.



25. Accessories connector: Remove the central front cover to reach them.

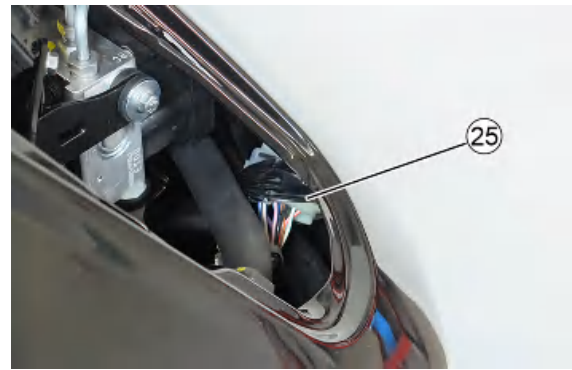

Instrument panel

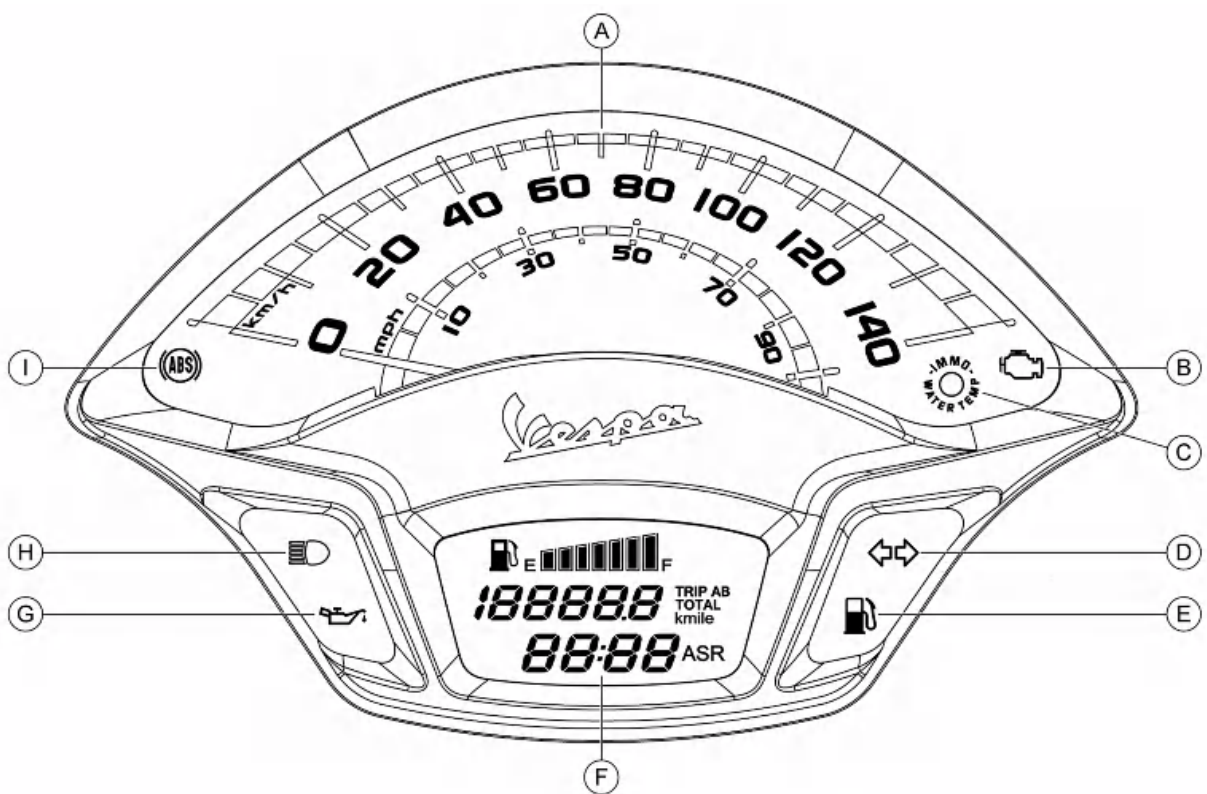

- A = Speedometer
- B = Engine control warning light
- C = Immobilizer / Engine temperature warning lamp
- D = Turn indicator warning light
- E = Low fuel warning light
- F = Digital display
- G = Low engine oil pressure warning light
- H = High beam warning light
- I = ABS warning light

MY 2019 VERSION

**Key:**

- A** = Speedometer
- B** = Ambient temperature indicator
- C** = Ice hazard icon
- D** = Multifunctional panel
- E** = "Vespa MIA" icon panel
- F** = Graphics ad infotainment panel
- G** = Maintenance icon
- H** = Low fuel warning light
- I** = Fuel gauge
- L** = Clock (12h or 24h format)
- M** = Speed limit indicator via the navigation system

By turning the ignition switch to "ON" position and then to "OFF" position, the digital display will show a "Welcome" and "Good bye".

The **MODE** joystick allows the cyclic display of the information shown on the multifunction panel of the digital display. It also allows navigation in the «**settings**» menu and setting various parameters. This is possible by pressing or moving the joystick in the four directions with short or long presses.

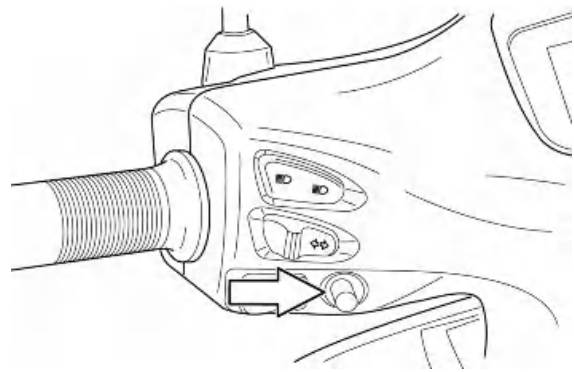

N.B.



"PRESS BRIEFLY AND RELEASE": PRESS THE BUTTON AND RELEASE WITHIN 0.5 SECONDS;
 "PRESS AND HOLD": PRESS THE BUTTON AND HOLD FOR AT LEAST 2 SECONDS.

MAINTENANCE ICON

This function indicates the scheduled maintenance interventions. For each time the key is turned to "ON", once the instrument panel has performed the initial check, if the value of the remaining kilometres until the next intervention is less than 300 Km (186.41 mi), the indicated icon will flash for 5 seconds. When the service mileage is reached, with each key "ON", the icon remains switched on steady until it is reset after the service operations are carried out.



MAINTENANCE ICON RESET

To reset the maintenance icon, proceed as follows:

- Turn the ignition switch to "ON";
- Briefly press the MODE joystick upward or downward until the "Battery charge state" function is displayed at the centre of the digital display.

N.B.



"PRESS BRIEFLY AND RELEASE": PRESS THE BUTTON AND RELEASE WITHIN 0.5 SECONDS;
 "PRESS AND HOLD": PRESS THE BUTTON AND HOLD FOR AT LEAST 2 SECONDS.



- Press and hold the MODE button for at least 10 seconds but not more than 15 seconds. Upon releasing it, the maintenance icon switches off.

If the MODE joystick is released without waiting 10 seconds, the maintenance icon will not switch off and the service interval counter will not be reset.

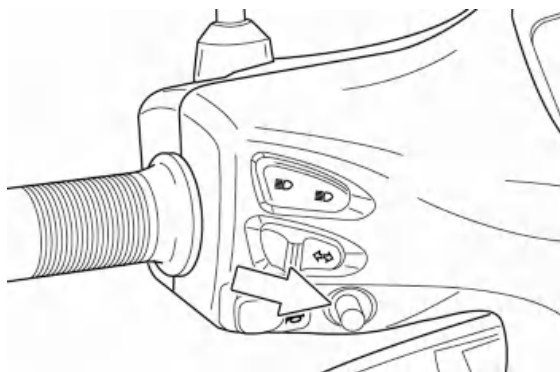

CAUTION



THE MAINTENANCE ICON RESET PROCEDURE MAY ONLY BE PERFORMED WHEN THE VEHICLE IS AT A STANDSTILL (SPEED = 0 Km/h).

AMBIENT TEMPERATURE INDICATION

Each time the key is turned to "ON", the digital display will show the ambient temperature in ° C or in ° F.

If the ambient temperature is less than 3°C (37.4° F), the digital display indicates with the specific symbol the potential presence of ice on the road. In such conditions, it is recommended to drive carefully. To select the desired unit of measurement, enter the «**settings**» menu as described below.



MULTIFUNCTIONAL PANEL

The multifunctional panel displays the following information cyclically, by briefly pressing the MODE joystick upward or downward:

N.B.



"PRESS BRIEFLY AND RELEASE": PRESS THE BUTTON AND RELEASE WITHIN 0.5 SECONDS;
"PRESS AND HOLD": PRESS THE BUTTON AND HOLD FOR AT LEAST 2 SECONDS.



1. Settings
2. Total odometer
3. Trip odometer
4. Trip time
5. Maximum speed
6. Average speed
7. Battery charge state
8. Current consumption
9. average consumption
10. Range

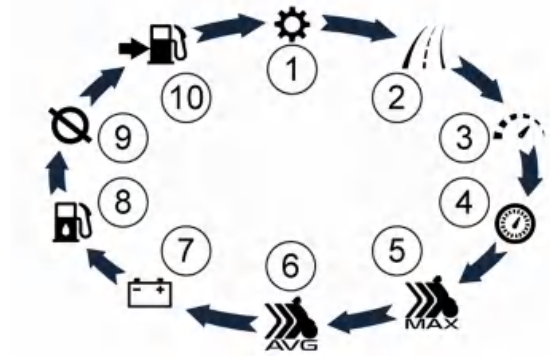

WARNING



THE "SETTINGS" FUNCTION CAN ONLY BE ACCESSED WITH THE VEHICLE AT A STANDSTILL.

While displaying one of the following functions:

- partial odometer
- trip time
- maximum speed
- average speed
- average consumption

by holding the MODE joystick pressed toward the **CENTRE**, all values are reset.

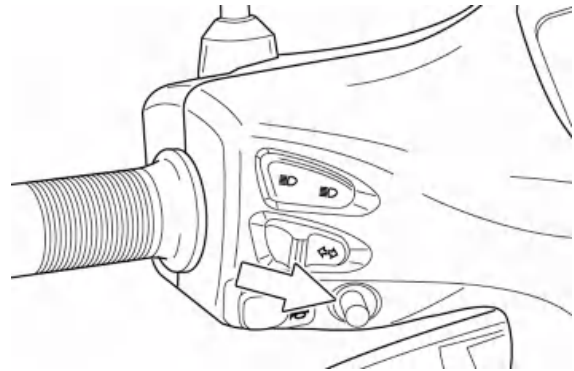

SETTINGS MENU

When the vehicle is at a standstill, briefly press the joystick up or down several times to display the «**settings**» function at the centre of the multifunctional panel. The «**settings**» menu can be accessed with a prolonged press on the central button of the joystick .



Briefly press the joystick up or down to highlight the desired function, with a short press on the central button of the joystick, you can select:

- Language
- Configuration
- Backlight
- Graphic



LANGUAGE SETTING

Briefly press the joystick up or down to highlight the desired function. Select the desired language via a short press on the central button of the joystick. The selection excludes the others.



CONFIGURATION MENU

Highlight the «**Configuration**» function via a short press on the central button of the joystick; enter the menu where it is possible to configure:

- Clock
- Measurement Units (Units)
- Pairing configuration



CLOCK SETTING (CLOCK)

Highlight the "**Clock**" function via a short press on the central button of the joystick and enter the menu.

CAUTION



FOR SAFETY, THE CLOCK SETTING FUNCTION IS ONLY AVAILABLE AT A VEHICLE SPEED OF 0 KM/H.

WARNING



DISCONNECTING THE BATTERY CABLES WILL RESULT IN A RESET OF THE CLOCK



Select the desired format between 12h or 24h.

The selection excludes the others.

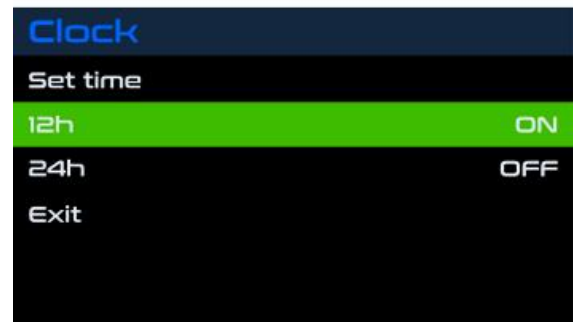

Highlight the "Set time" function via a short press on the central button of the joystick and enter the menu.

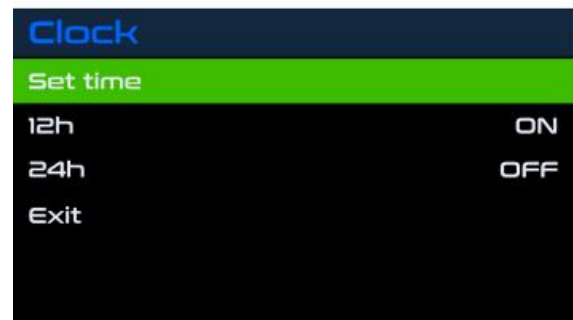

Highlight the "Hour" function. Via a short press on the central button of the joystick, enter the menu.



Briefly press the joystick up or down to set the correct hour. Briefly press the joystick central button to confirm. The green bar confirms the selection.



Highlight the **"Minutes"** function. Via a short press on the central button of the joystick, enter the menu.



Briefly press the joystick up or down to set the correct minutes. Briefly press the joystick central button to confirm. The green bar confirms the selection.

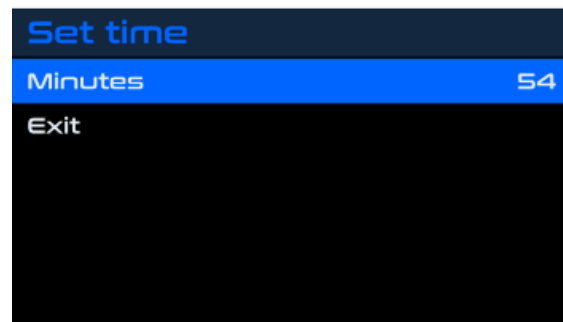

MEASUREMENT UNITS MENU (UNITS)

Highlight the **"Units"** function via a short press on the central button of the joystick and enter the menu where it is possible to configure:

- Speed
- Temperature



SETTING THE SPEED UNIT OF MEASUREMENT (SPEED)

Highlight the **"Speed"** function. Via a short press on the central button of the joystick, enter the menu.



Select the desired format between Km/h or mph.
The selection excludes the others.



SETTING THE TEMPERATURE UNIT OF MEASUREMENT (TEMPERATURE)

Highlight the "Temperature" function. Via a short press on the central button of the joystick, enter the menu.

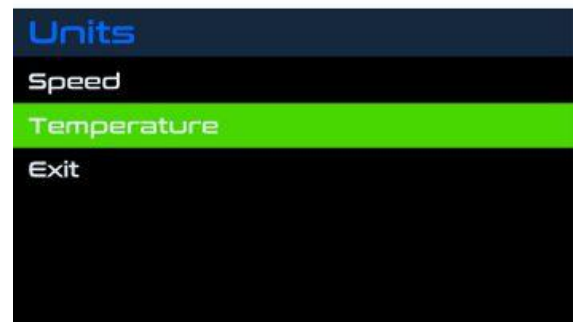

Select the desired format between °C or °F. The selection excludes the others.



PAIRING CONFIG. MENU (PAIRING CONFIGURATION)

The vehicle is equipped with the "Vespa MIA" control unit that communicates with the smartphone via Bluetooth. Using the specific "Vespa" application installed on the smartphone, it is possible to exchange data with the vehicle and manage multimedia contents. Once a connection is established correctly between the control unit and the smartphone, the following functions can be directly managed by the digital display of the vehicle:

- manage phone calls;
- manage audio playback;



- SMS notifications management;
- GPS navigation.

Highlight the "**Pairing configuration**" function.

Via a short press on the central button of the joystick, enter the menu.



Highlight the "**Pairing request**" function and briefly press the central button of the joystick.



The digital display shows the message confirming that pairing with the smartphone is enabled. Enable the bluetooth search on your smartphone, select the "**BT-ROUTER**" device, and, if required, type the password "0000" and press on pair.

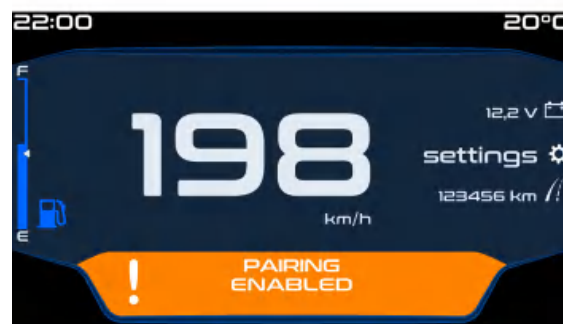

The smartphone will display the "**BT-ROUTER**" device in the associated devices list. Wait for the digital display to automatically connect the smartphone. **Do NOT force the connection from the telephone.** The smartphone icon on the display indicates active communication. **When requested, allow phone book and notifications sharing.** These authorizations are required to display the caller's name and the SMS reception notification on the display.



N.B.

UPON THE FIRST PAIRING BETWEEN THE DISPLAY AND SMARTPHONE, MORE TIME MAY BE REQUIRED FOR THE SYNCHRONIZATION OF THE PHONE BOOK. THE SUCCESSFUL CONNECTION BETWEEN THE SMARTPHONE AND VEHICLE WILL BE INDICATED BY THE SMARTPHONE ICON LIGHTING UP ON THE DISPLAY.

If the association between the smartphone and the vehicle is not successful, proceed as follows:

- restart the smartphone;
- turn the ignition key to "OFF" and then to "ON"; wait until the animation on the display ends.

If the smartphone icon on the display has not lit after about 1 minute, select the **"Pairing reset"** function and briefly press the central button of the joystick.



All stored Bluetooth devices are deleted from the **"Vespa MIA"** system.

The display shows the message confirming the deletion. The smartphone pairing procedure can be repeated.

N.B.

PLEASE NOTE THAT TO CONNECT THE APP TO THE VEHICLE AGAIN, THE FOLLOWING WILL BE NECESSARY:

- ON IOS, DELETE THE PREVIOUSLY INSTALLED APP AND REINSTALL IT.
- ON ANDROID IT WILL NECESSARY AND SUFFICIENT TO DELETE THE APPLICATION DATA FROM THE APP MANAGEMENT MENU (THIS WILL RESET THE APPLICATION TO DEFAULT SETTINGS AND IT WILL BE NECESSARY TO PERFORM THE LOGIN AND THE FIRST CONNECTION TO THE VEHICLE AGAIN).
- IN CASE OF CONNECTION TO A NEW VEHICLE, IT IS NECESSARY TO REMOVE THE PREVIOUS BT-ROUTER FROM THE ASSOCIATED DEVICES.

N.B.

IT IS RECOMMENDED TO ASSOCIATE MAXIMUM N. 2 SMARTPHONES AND 1 HEADSET TO THE SAME VEHICLE, TO OPTIMIZE THE SYSTEM OPERATION. IF TWO SMARTPHONES ARE PAIRED, THE CONNECTION OF THE FIRST SMARTPHONE PAIRED WITH THE "BT-ROUTER" COULD REQUIRE MORE THAN 30 SECONDS. ONCE THE SMARTPHONE IS CONNECTED TO THE "BT-ROUTER", THE OPERATING SYSTEM REQUIRES ACCESS TO THE PHONE BOOK AND NOTIFICATIONS; ACCEPT TO BE ABLE TO VIEW THE NAME OF THE CALLERS AND THE SMS RECEIPT NOTIFICATIONS ON THE DISPLAY.



CONNECTION BETWEEN THE APPLICATION AND THE DIGITAL DISPLAY

Search for the "**Vespa**" application in Play Store or App Store and install it. Register your account by following the instructions. Select "**allow**" for the location and notification requests.



Open the "**Vespa**" application on the smartphone and access your account. On the application's main page select "**Connect**". Select your vehicle model; the digital display will show the icon of the "**Vespa**" app, confirming the successful activation of the communication between the app and Vespa.



BLUETOOTH HEADSET PAIRING

The multimedia functions can be used with the MODE joystick, by pairing a bluetooth headset with the digital display via the "**Vespa**" application. After pairing, it will be possible to answer or reject calls, activate voice commands and manage the music on the smartphone.

Activate the "**pairing**" mode of the bluetooth headset to be paired (refer to the instructions of the device). Press the Bluetooth icon on the main screen of the "**Vespa**" application and search for new devices until the headset is displayed. Select the bluetooth headset, check the "**Hands-free / Driver headset**" option and press "**Pair**". The successful pairing is indicated by the headset icon displayed on the digital display.

If the pairing is not successful, perform a new search.



No multimedia function can be managed from the handlebar of the vehicle if there is no bluetooth headset, or if the headset is directly connected to the smartphone. **The bluetooth headset can be associated to the vehicle only via the "Vespa" application and it must be connected to the vehicle in order to correctly use the multimedia functions of the system. For this reason, the headsets that automatically connects to the smartphone are not compatible (Ex: Apple Air-pod).**



Required operation for iOS 10.0 versions or higher

If the "BT-ROUTER" does not automatically require access to notifications, it will be necessary to proceed as follows:

- Enter the menu: "Settings" > "Bluetooth" > "Telephone devices";
- select "BT-ROUTER", select "Info", enable the options manually;
- for iOS systems, the SMS notifications will be enabled starting from the moment in which the ignition key is turned to "ON", AFTER the one in which the options have been manually enabled.

If it is necessary to disconnect the smartphone, proceed as follows. Highlight the **'Pairing reset'** function and briefly press the central button of the joystick.

N.B.

THIS OPERATION IS NECESSARY WHEN THE SMARTPHONE IS REPLACED.

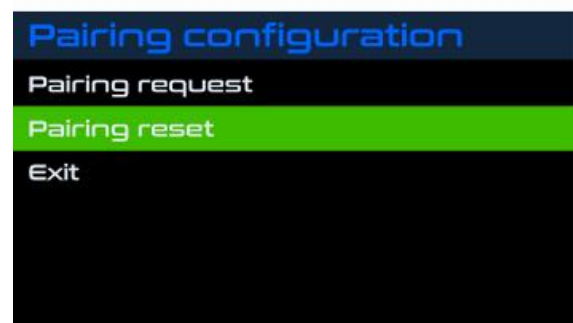

All stored Bluetooth devices are deleted from the "Vespa MIA" system. The display shows the message confirming the deletion. The pairing procedure can be repeated for a new smartphone.



BACKLIGHT MENU (BACKLIGHT)

Highlight the "**Backlight**" function via a short press on the central button of the joystick and enter the menu where it is possible to configure:

- Backlight mode: Automatic, Day, Night
- Brightness level (Settings)



Briefly press the joystick up or down to highlight the desired function. Confirm the selected option with a short press of the central button of the joystick. The selection excludes the others.



The "**Automatic**" option allows automatic switching between the day and night graphics depending on the light detected by the brightness sensor located on the instrument panel.

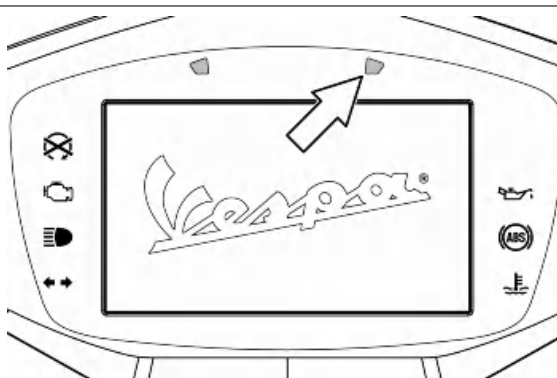

Highlight the "**Setting**" function. Via a short press on the central button of the joystick, enter the menu.



Highlight the "**Day**" function. Via a short press on the central button of the joystick, enter the menu. The default value is 4.

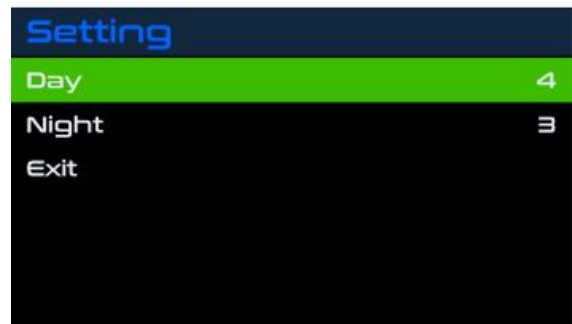

Briefly press the joystick up or down to set the desired brightness level. Briefly press the joystick central button to confirm. The green bar confirms the selection.



Highlight the "**Night**" function. Via a short press on the central button of the joystick, enter the menu. The default value is 3.



Briefly press the joystick up or down to set the desired brightness level. Briefly press the joystick central button to confirm. The green bar confirms the selection.



GRAPHIC MENU (GRAPHIC)

Highlight the "Graphic" function with a short press of the central button of the joystick. Via a short press on the central button of the joystick, enter the menu.



Various background graphics can be selected for the digital display. Briefly press the joystick up or down to highlight the desired function. Confirm the selected option with a short press of the central button of the joystick. The selection excludes the others.

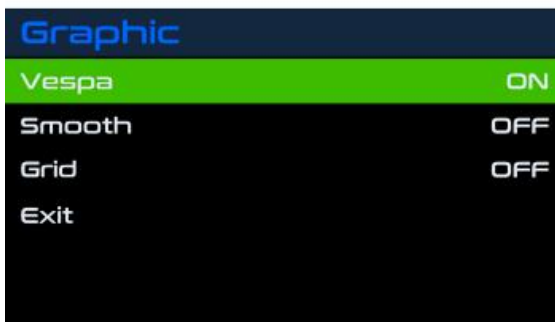

"VESPA MIA" SYSTEM MESSAGES

The "Vespa MIA" system communicates with the user by means of messages displayed on the graphic panel of the digital display. Depending on the message type, the graphic panel shows the icon, colours and the specific message. The image on the side shows:

- Text alarms;
- Caution messages;
- Information messages.

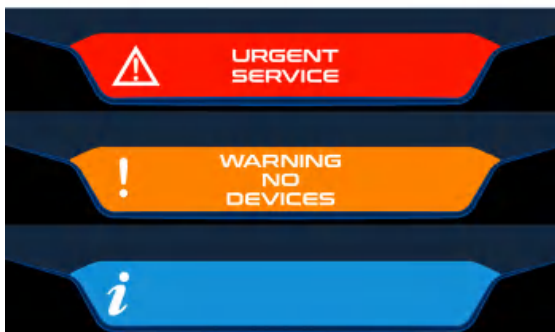

N.B.



JOYSTICK COMMANDS ARE IGNORED WHEN A POPUP WINDOW IS ACTIVE ON THE DISPLAY. THE POPUP WINDOW MUST BE CLEARED FROM THE DISPLAY TO RESTORE NORMAL OPERATION WITH A PROLONGED PRESS ON THE CENTRAL BUTTON OF THE JOYSTICK.

PHONE CALLS AND SMS MESSAGES MANAGEMENT

To use phone features, view caller notifications and identifiers, it is necessary to:

- pair the smartphone with the "Vespa MIA" system via bluetooth, as previously described;
- install and access your "Vespa" application account on the smartphone;
- pair a bluetooth headset with the «Vespa MIA» system using the "Vespa" application;
- allow the address book and notifications sharing during the Bluetooth pairing of the smartphone with the "Vespa MIA" system.

The corresponding three icons are shown on the digital display. Please note that on iOS systems the message notifications will be displayed **ONLY** at the second connection of the smartphone to the vehicle.



N.B.



WHEN A SMARTPHONE CONNECTS WITH THE VESPA MIA SYSTEM (BT-ROUTER), AUDIO IS AUTOMATICALLY ROUTED TO THE VESPA MIA SYSTEM. IF THERE IS NO HEADSET CONNECTED TO THE "VESPA MIA" SYSTEM, THE AUDIO FUNCTION OR MUSIC PLAYBACK CANNOT BE MANAGED, THEREFORE THE SMARTPHONE AUDIO MUST BE MANUALLY ROUTED TO THE DESIRED DEVICE (e.g. SPEAKERS/TELEPHONE MICROPHONE).

The following information appears on the digital display:

- call in progress;
- call ended;
- SMS, email, generic notification;
- active vocal management.

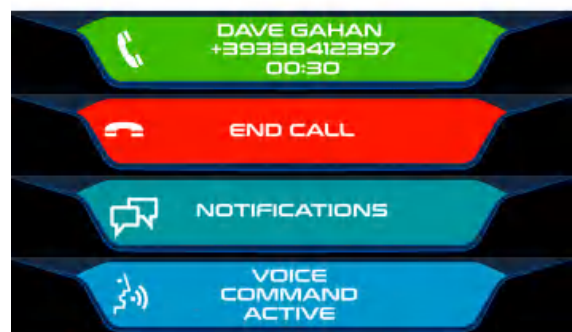

Use the MODE joystick for phone call management, as indicated in the table:

MODE JOYSTICK FUNCTIONS FOR PHONE CALL MANAGEMENT

Specification	Desc./Quantity
Accept incoming call	CENTRAL BUTTON BRIEF PRESS
End an active call	CENTRAL BUTTON LONG PRESS

Specification	Desc./Quantity
Reject incoming call	CENTRAL BUTTON LONG PRESS
Cancel outgoing call	CENTRAL BUTTON LONG PRESS
Clear most recent missed call popup (with NO call in progress)	CENTRAL BUTTON BRIEF PRESS
Redial last missed call number (with NO call in progress)	CENTRAL BUTTON LONG PRESS
Increase volume (with call in progress)	BRIEF UPWARD PRESS
Lower volume (with call in progress)	BRIEF DOWNWARD PRESS
Enable/disable voice command	SHORT DOUBLE CENTRAL PRESS

MUSIC PLAYBACK MANAGEMENT

To use the functions of the music player, the following must be performed:

- pair the smartphone with the "Vespa MIA" system via bluetooth, as previously described;
- install and access your "Vespa" application account on the smartphone;
- pair a bluetooth headset with the «Vespa MIA» system using the "Vespa" application.

The corresponding three icons are shown on the digital display.



N.B.



WHEN A SMARTPHONE CONNECTS WITH THE VESPA MIA SYSTEM (BT-ROUTER), AUDIO IS AUTOMATICALLY ROUTED TO THE VESPA MIA SYSTEM. IF THERE IS NO HEADSET CONNECTED TO THE "VESPA MIA" SYSTEM, THE AUDIO FUNCTION OR MUSIC PLAYBACK CANNOT BE MANAGED, THEREFORE THE SMARTPHONE AUDIO MUST BE MANUALLY ROUTED TO THE DESIRED DEVICE (e.g. SPEAKERS/TELEPHONE MICROPHONE).

The following information appears on the digital display:

- track playback;
- playback paused;
- playback suspended;
- forward (or reverse) track scrolling.

WARNING



A PLAYLIST MUST BE OPENED FROM THE SMARTPHONE BEFORE STARTING YOUR TRIP OR THROUGH VOCAL COMMANDS IF YOU ARE TRAVELLING.

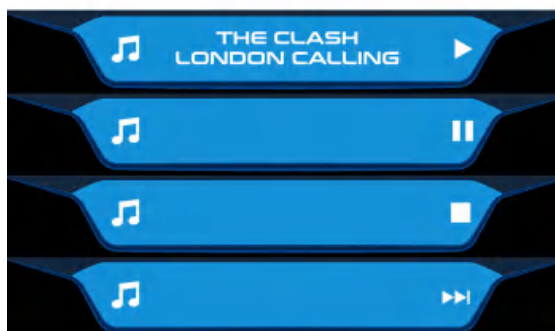

Use the MODE joystick for music playback management, as indicated in the table:

MODE JOYSTICK FUNCTIONS FOR MUSIC MANAGEMENT

Specification	Desc./Quantity
Music playback/pause	CENTRAL BUTTON BRIEF PRESS
Increase audio volume (with audio playback in progress)	BRIEF PRESS UPWARD
Lower audio volume (with audio playback in progress)	BRIEF PRESS DOWNWARD

Specification	Desc./Quantity
Next music track	PRESS SELECTOR BRIEFLY TO THE RIGHT
Previous audio track	PRESS SELECTOR BRIEFLY TO THE LEFT
Exit audio playback mode	CENTRAL BUTTON LONG PRESS

GPS NAVIGATION

Combined with the "Vespa" application, the "Vespa MIA" system allows the display of GPS indications on the digital display. By means of pictograms, distance and travel time data, the desired destination can be reached.

Refer to the navigation guide by accessing the "Vespa" application with your account. After setting the destination address and navigation is started, the navigation icon is shown on the digital display..



By holding the MODE joystick pressed to the RIGHT, the GPS indications screen is accessed. During navigation, you can return to the instrument panel home screen at any time (and vice versa) while keeping the navigation active.

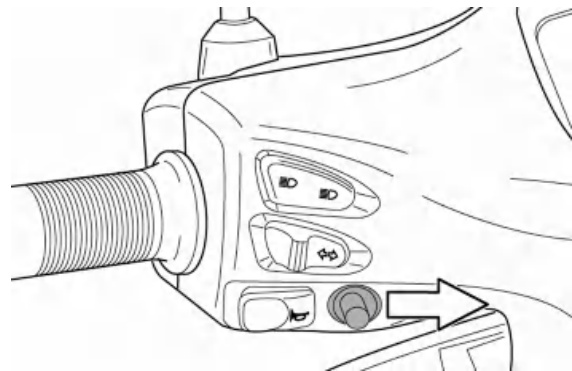

N.B.
BY SETTING THE DESTINATION ADDRESS VIA THE "VESPA" APPLICATION, THE DIGITAL DISPLAY AUTOMATICALLY DISPLAYS THE INDICATION SCREEN.

N.B.



"PRESS BRIEFLY AND RELEASE": PRESS THE BUTTON AND RELEASE WITHIN 0.5 SECONDS;
"PRESS AND HOLD": PRESS THE BUTTON AND HOLD FOR AT LEAST 2 SECONDS.



NAVIGATION SCREEN KEY

- A** = destination or next turn address;
- B** = indication following the next manoeuvre;
- C** = distance to the next manoeuvre;
- D** = remaining time until reaching the destination;
- E** = remaining distance until reaching the destination;
- F** = next manoeuvre indication;
- G** = distance related to indication "F";
- H** = exit number to follow at a roundabout;
- I** = indication regarding the speed limit on the road travelled;
- L** = indication regarding the current speed (tachometer).

Ground points

There are two ground connections on the vehicle:
 The engine ground, indicated with the letter "A".
 The chassis ground, indicated with the letter "B".
 Located in the rear left of the vehicle, to access them remove the helmet compartment.

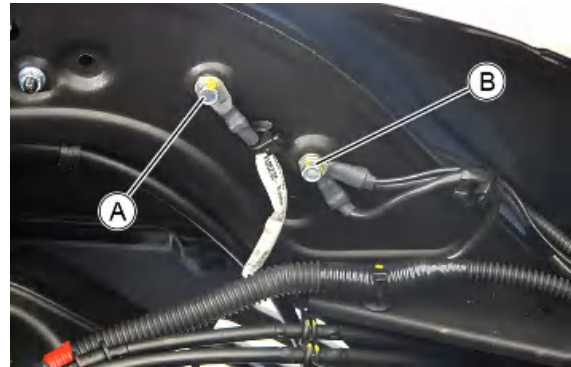

Electrical system installation

Front side

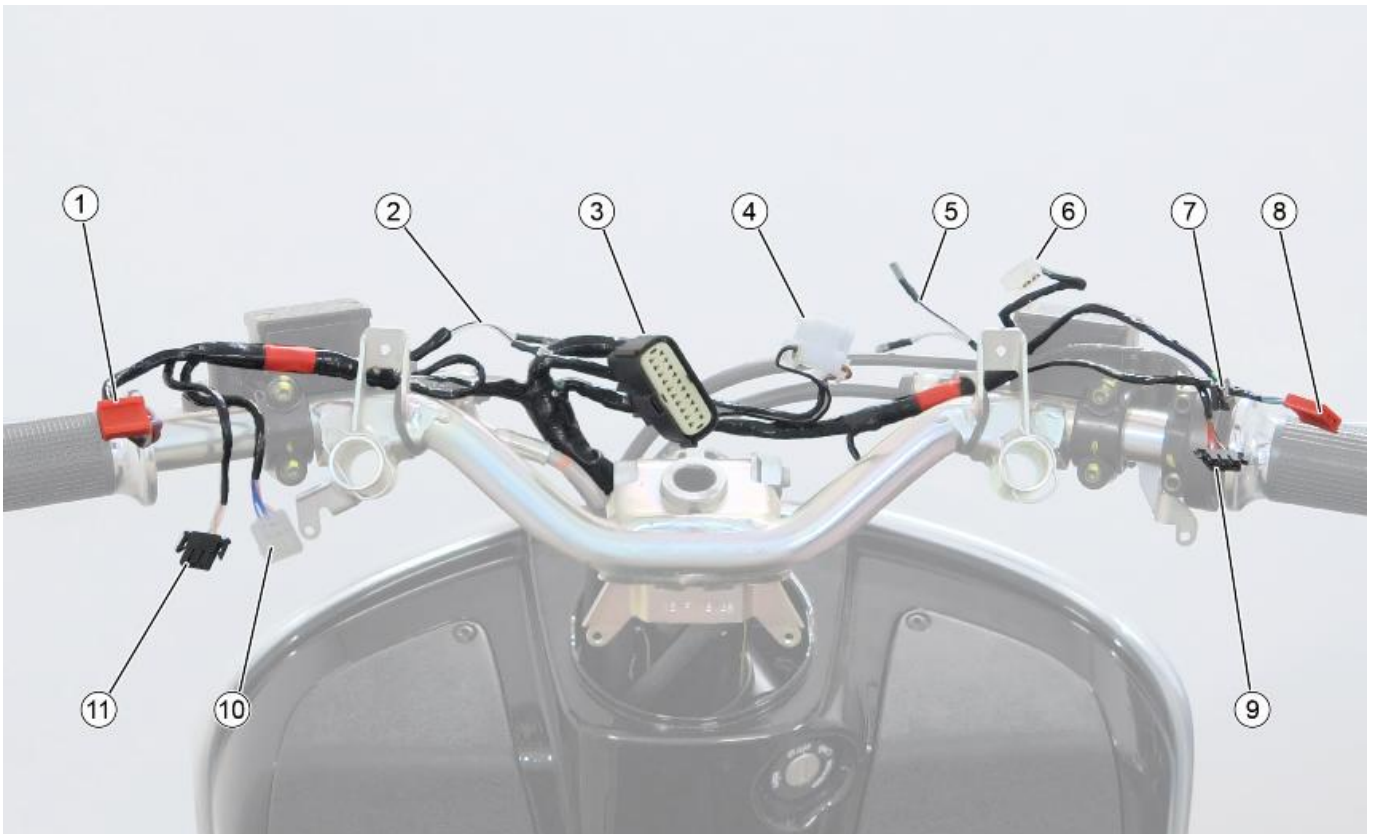

1. Turn indicators connector.
2. Rear braking system stop switch connector.
3. Instrument panel connector.
4. Headlight connector.
5. Front braking system stop switch connector.
6. ASR Button connector
7. MODE button connector
- 8.
- 9.
- 10.
- 11.

- 8. Engine stop switch connector
- 9. Starter button connector
- 10. Light switch connector
- 11. Horn button connector

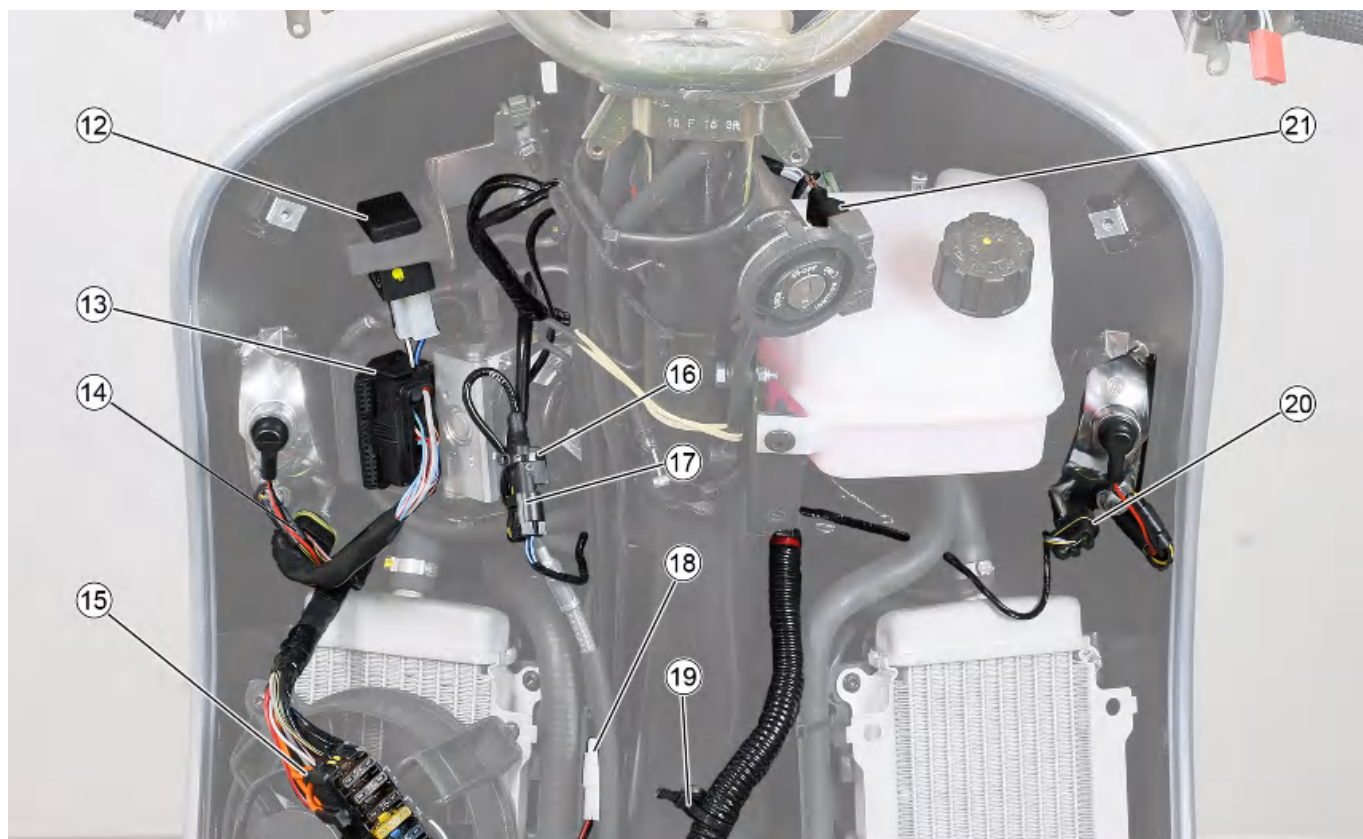

- 12. Blinker.
- 13. ABS Control unit connector.
- 14. Front left turn indicator connector and DRL light
- 15. Fuse box terminal block
- 16. Fasten the cable of the front tone wheel sensor with clamp.
- 17. Front tone wheel sensor connector.
- 18. Electric fan connector.
- 19. Clamp the cable harness.
- 20. Front right turn indicator connector and DRL light
- 21. Immobilizer antenna connector.

Back side

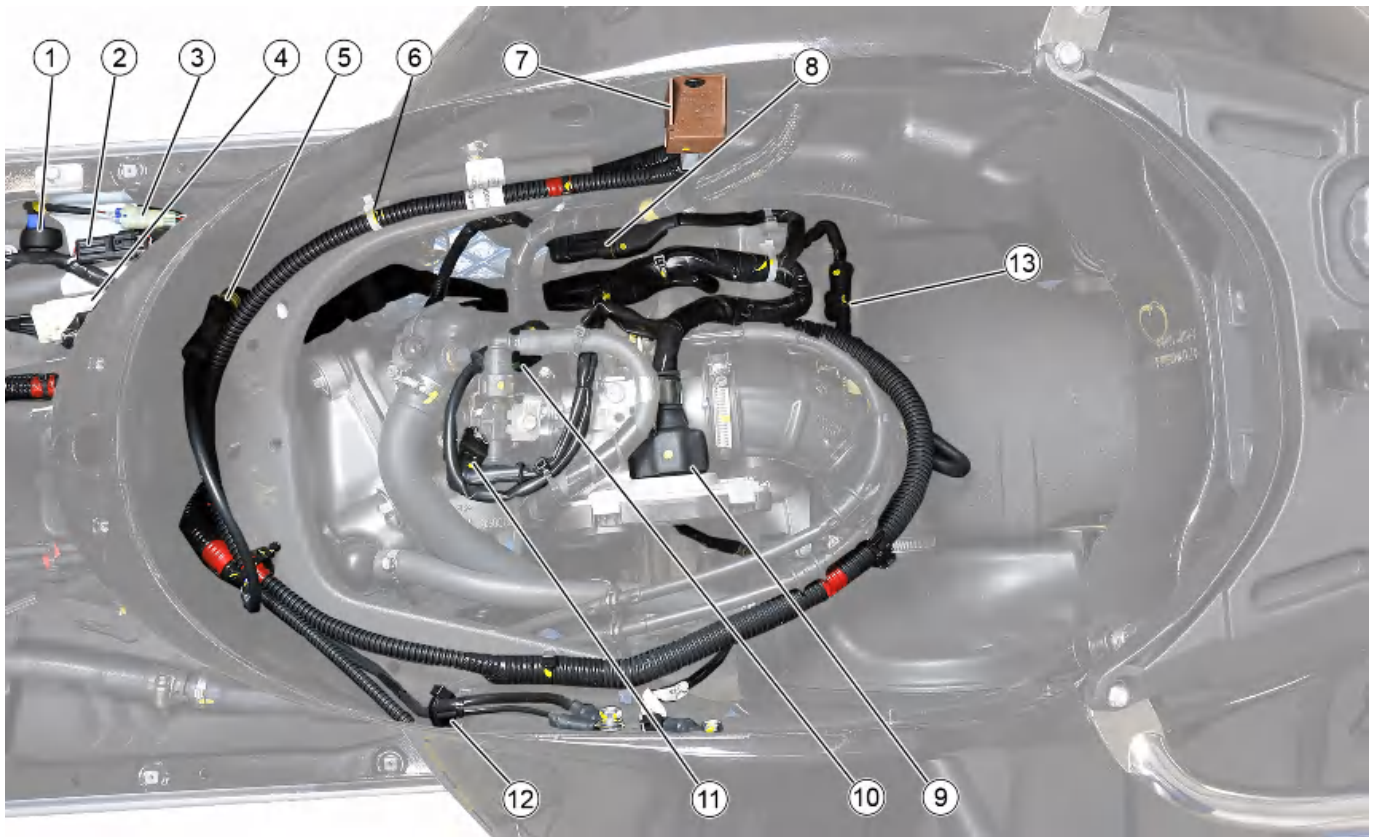

1. Tilting sensor.
2. Pick-up connector.
3. Tilting sensor connector
4. Voltage regulator connector.
5. Diagnostic connector
6. Insert the clamp on the starter motor cable in the hole on the body shell.
7. Starter relay.
8. Lambda probe connector
9. Injection ECU connector
10. Engine temperature sensor connector
11. Injector connector
12. Clamp the earth cables.
13. Rear tone wheel sensor connector.

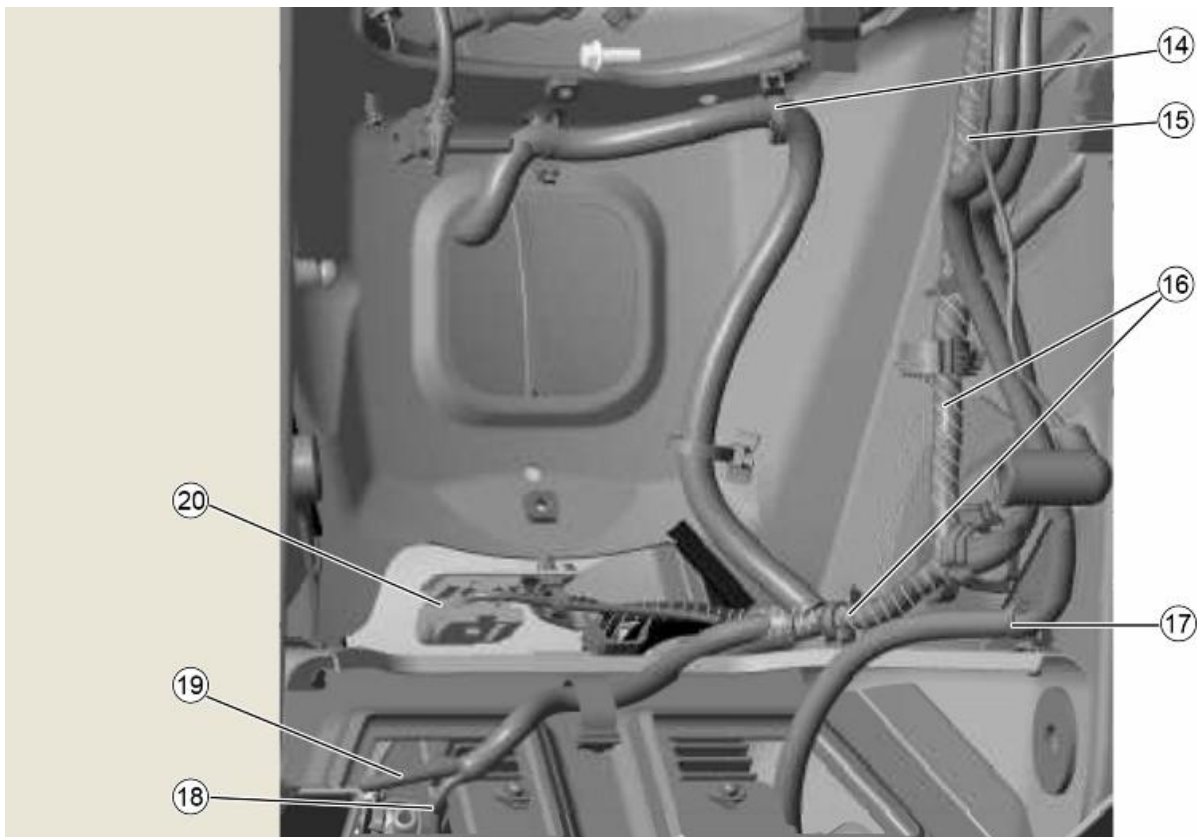

14. insert the clamp in the hole on the body shell.

15. To the starter relay.

16. Pay attention, improper assembly of these cables can lead to the vehicle catching fire.

17. Insert the clamp on the flywheel cable in the hole on the body shell.

18. To the side stand switch

19. To the H.V. coil

20. Main fuse.

Conceptual diagrams

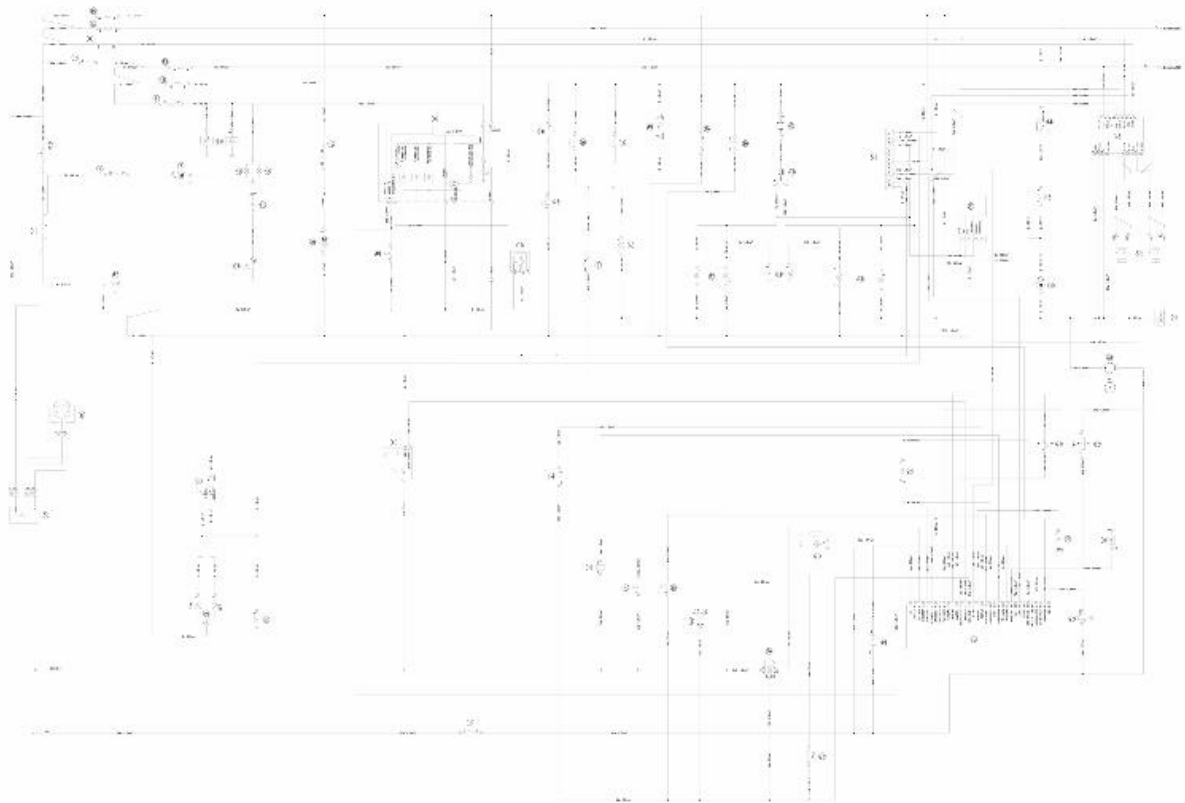

KEY

1. Battery 12V-10Ah
2. Starter relay
3. Starter motor
4. Starter button
5. Voltage regulator
6. Magneto flywheel
7. Fuse No.1 - 30A
8. Fuse No. 5 - 7.5A
9. Fuse No. 2 - 15A
10. Fuse No. 6 - 7.5A
11. Fuse No. 3 - 15A
12. Fuse No. 4 - 7.5A
13. Fuse No. 7 - 7.5A
14. Ignition switch contacts
15. Engine stop switch
16. 2 stop buttons
17. Stop light bulb 12V-16W

18. Injection load relay
19. Electric fan relay
20. Radiator electric fan
21. Horn button
22. Horn
23. Lambda probe
24. Engine speed sensor
25. H.V. coil
26. Fuel injector
27. Engine temperature sensor
28. Fuel pump
29. Diagnosis socket
30. Electronic injection control unit
31. Immobilizer antenna
32. Fuel level transmitter
33. Oil pressure sensor
34. Instrument cluster
35. Light switch
36. Headlight contactor
37. Saddle release switch
38. Saddle opening actuator
39. Headlight with twin-filament bulb 12V-55W/60W
40. Turn indicator control device
41. Turn signal switch
42. 4 bulbs for left turn indicators 12V-6W*
43. Pre-installation for anti-theft device
44. 2 LED front daylight running light bulbs
45. 1 LED rear daylight running light bulbs 12V-5W
46. 1 licence plate light 12V-5W
47. Chassis engine ground 48 MODE button
49. USB port
50. Wiring for accessories - connector
51. Bike Finder
52. ABS control unit
53. ABS sensors
54. ASR Button
55. Stand button
56. Roll-over sensor

57. Lambda heater

Ignition

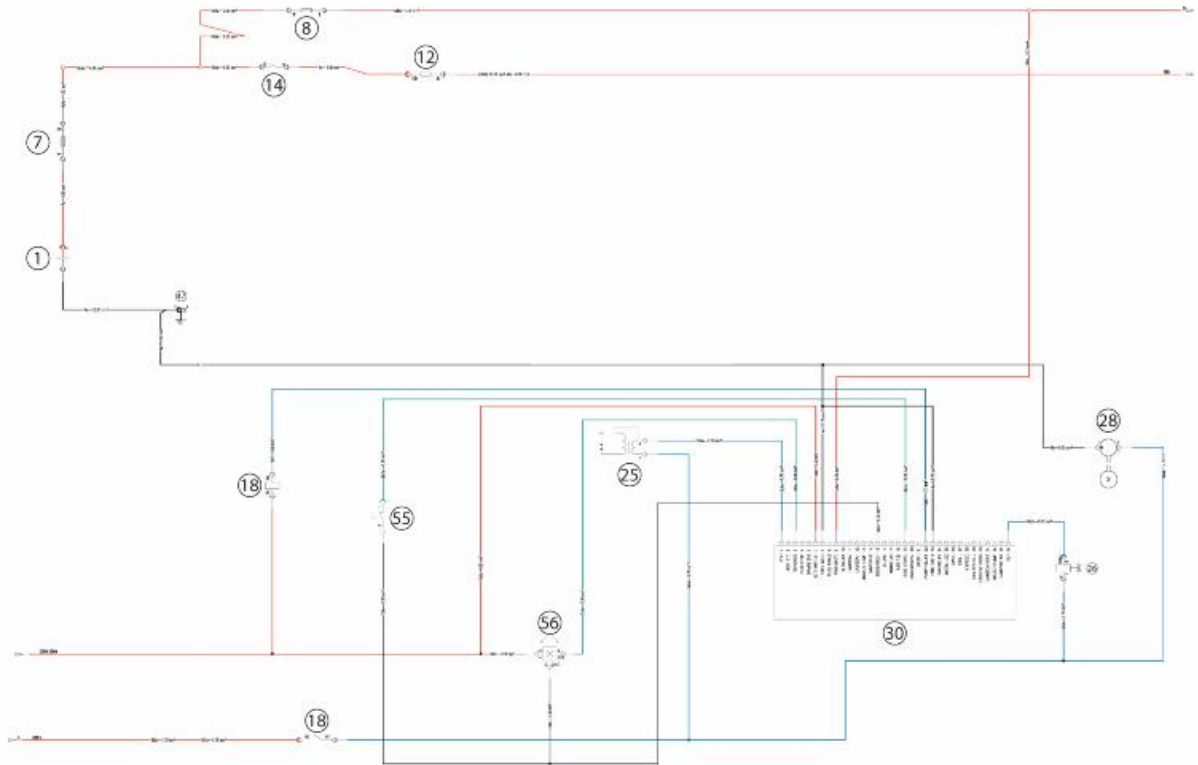

KEY

- 1. Battery 12V-10Ah
- 7. Fuse No.1 - 30A
- 8. Fuse No. 5 - 7.5A
- 12. Fuse No. 4 - 7.5A
- 14. Ignition switch contacts
- 18. Injection load relay
- 25.H.V. coil
- 26. Fuel injector
- 28.Fuel pump
- 47. Chassis engine ground
- 55. Stand button
- 56. Roll-over sensor
- 30. Electronic injection control unit

Battery recharge and starting

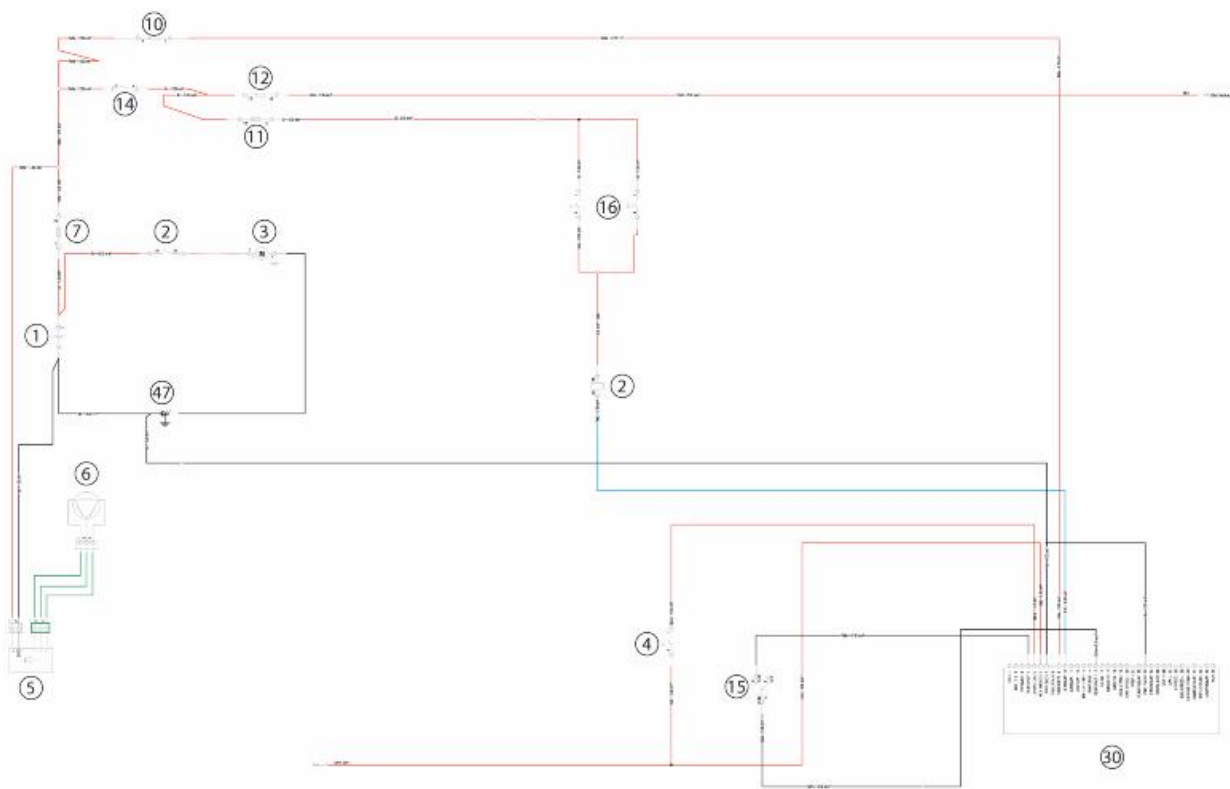

KEY

- 1. Battery 12V-10Ah
- 2. Starter relay
- 3. Starter motor
- 4. Starter button
- 5. Voltage regulator
- 6. Magneto flywheel
- 7. Fuse No.1 - 30A
- 10. Fuse No. 6 - 7.5A
- 11. Fuse No. 3 - 15A
- 12. Fuse No. 4 - 7.5A
- 14. Ignition switch contacts
- 15. Engine stop switch
- 16. 2 stop buttons
- 30. Electronic injection control unit
- 47. Chassis engine ground

Level indicators and enable signals section

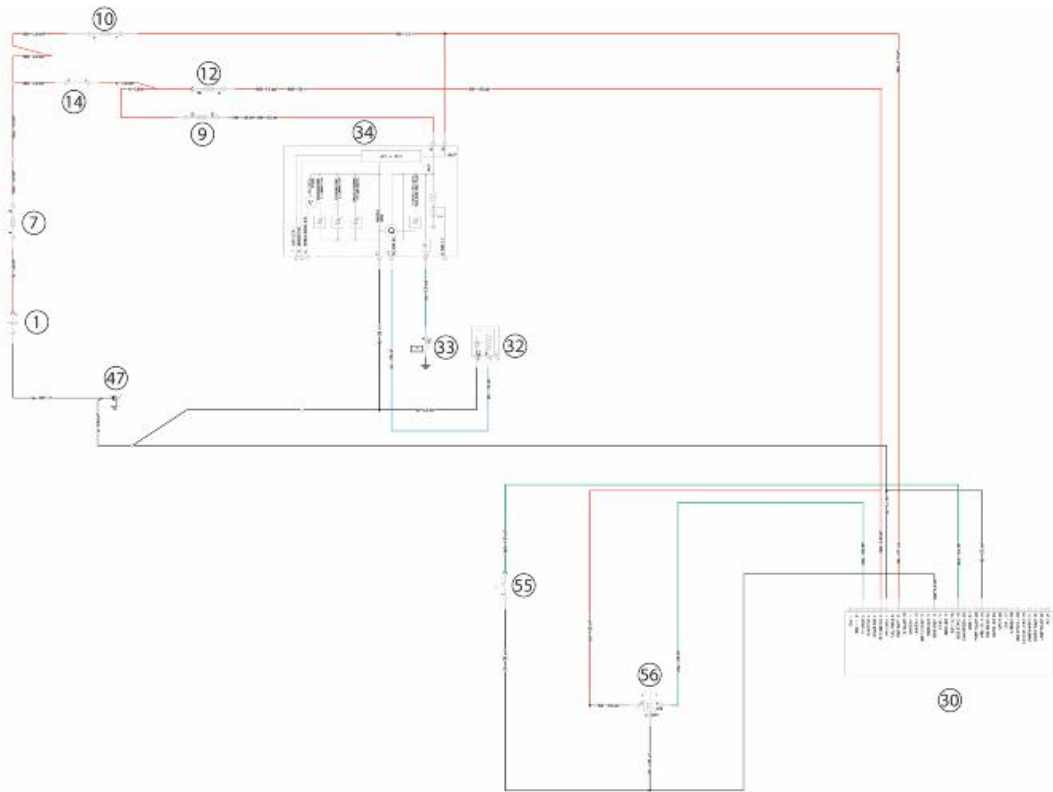

KEY

- 1. Battery 12V-10Ah
- 7. Fuse No.1 - 30A
- 9. Fuse No. 2 - 15A
- 10. Fuse No. 6 - 7.5A
- 14. Ignition switch contacts
- 30. Electronic injection control unit
- 32. Fuel level transmitter
- 33. Oil pressure sensor
- 34. Instrument cluster
- 47. Chassis engine ground
- 55. Stand button
- 56. Roll-over sensor

Turn signal lights

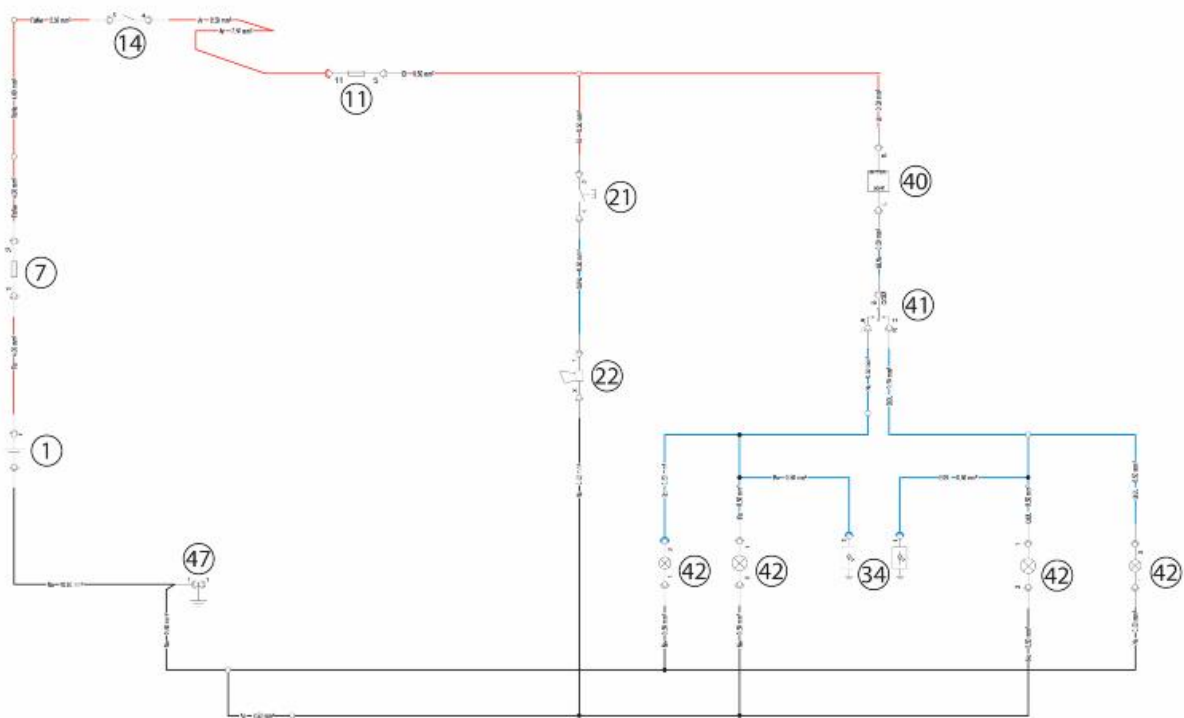

KEY

- 1. Battery 12V-10Ah
- 7. Fuse No.1 - 30A
- 11. Fuse No. 3 - 15A
- 14. Ignition switch contacts
- 21. Horn button
- 22. Horn
- 40. Turn indicator control device
- 41. Turn signal switch
- 42. 4 bulbs for left turn indicators 12V-6W*
- 47. Chassis engine ground

Devices and accessories

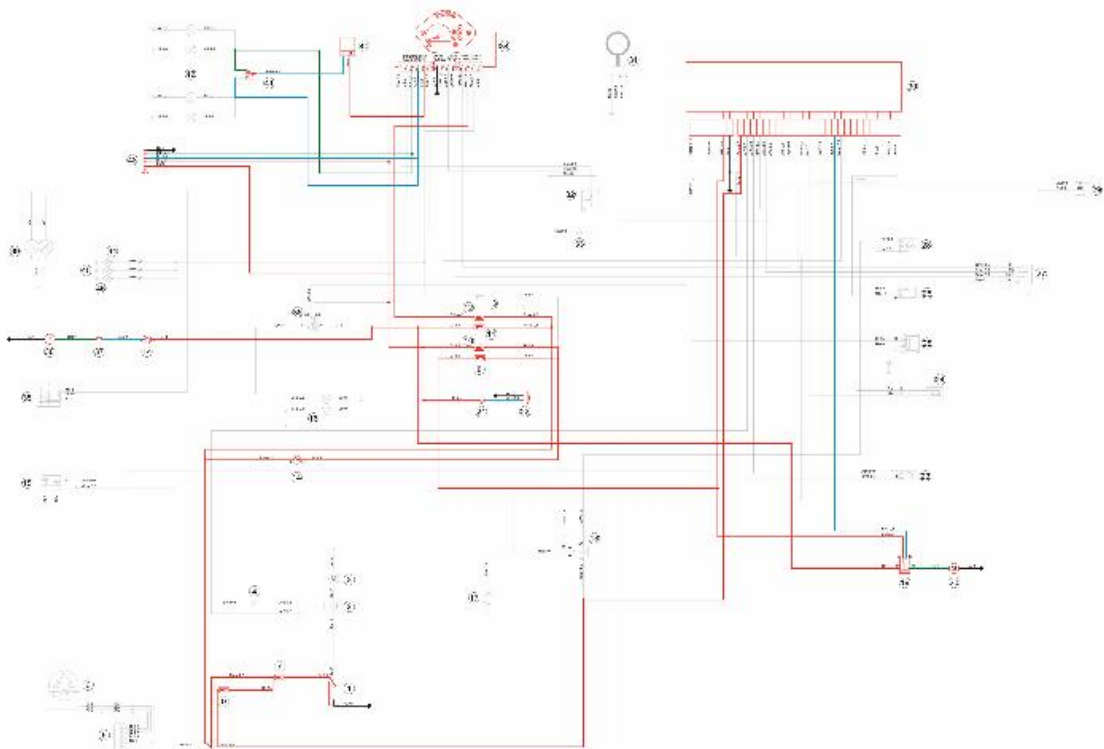

KEY

- 1. 12v-10Ah battery
- 7. Fuse No.1 - 30A
- 8. Fuse No. 5 - 7.5A
- 9. Fuse No. 2 - 15A
- 10. Fuse No. 6 - 7.5A
- 11. Fuse No. 3 - 15A
- 12. Fuse No. 4 - 7.5A
- 14. Ignition switch contacts
- 19. Electric fan relay
- 20. Radiator electric fan
- 21. Horn button
- 22. Horn
- 30. Electronic injection control unit
- 34. Instrument cluster
- 37. Saddle release switch
- 38. Saddle opening actuator
- 40. Turn indicator control device

- 41. Turn signal switch
- 43. Pre-installation for anti-theft device

Lights and turn indicators

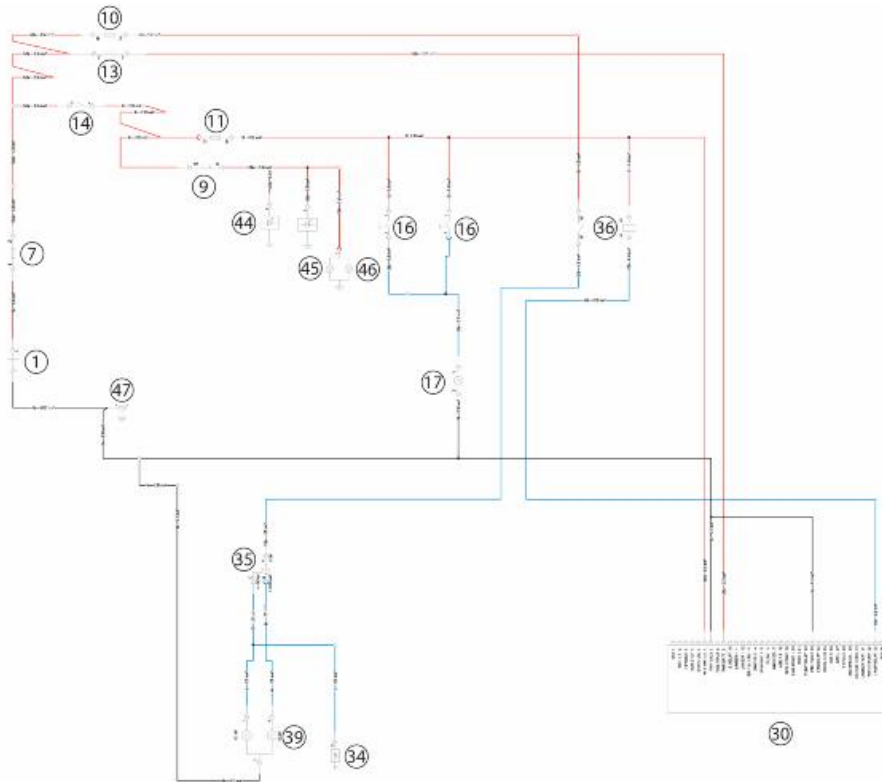

KEY

- 1. Battery 12V-10Ah
- 7. Fuse No.1 - 30A
- 10. Fuse No. 6 - 7.5A
- 11. Fuse No. 3 - 15A
- 16. 2 stop buttons
- 17. Stop light bulb 12V-16W
- 30. Electronic injection control unit
- 34. Instrument cluster
- 35. Light switch
- 36. Headlight contactor
- 39. Headlight with twin-filament bulb 12V-55W/60W
- 44. 2 LED front daylight running light bulbs
- 45. 1 LED rear daylight running light bulbs 12V-5W
- 46. 1 licence plate light 12V-5W
- 47. Chassis engine ground

Injection

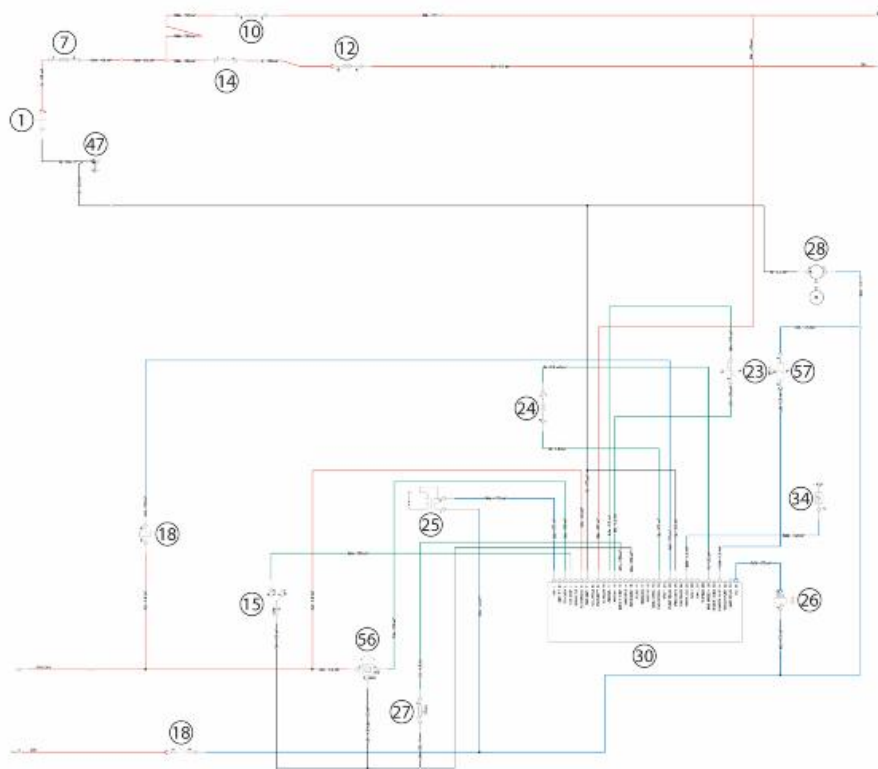

KEY

- 1. Battery 12V-10Ah
- 7. Fuse No.1 - 30A
- 10. Fuse No. 6 - 7.5A
- 12. Fuse No. 4 - 7.5A
- 14. Ignition switch contacts
- 15. Engine stop switch
- 18. Injection load relay
- 23. Lambda probe
- 24. Engine speed sensor
- 25. H.V. coil
- 26. Fuel injector
- 27. Engine temperature sensor
- 28. Fuel pump
- 30. Electronic injection control unit
- 34. Instrument cluster
- 47. Chassis engine ground
- 56. Roll-over sensor
- 57. Lambda heater

Checks and inspections

This section is dedicated to the checks on the electrical system components.

Immobiliser

The electronic ignition system is controlled by the injection electronic control unit with the integrated Immobilizer system. The immobilizer is an anti-theft system which allows the vehicle to work only if it is activated by means of the coded keys that the control unit recognises. The code is stored in a transponder installed in the body of the key. This allows the driver clear operation without having to do anything other than just turning the key.

The Immobilizer system consists of the following components: - injection electronic control unit. - immobilizer antenna - master key with built-in transponder - reserve key - diagnostic led on the instrument panel

The diagnosis LED also works as a theft-deterrent blinker. This function is activated every time the ignition switch is turned to the "OFF" position, or the emergency stop switch is turned to the "OFF" position. It remains activated for 48 hours in order not to affect the battery charge. When the ignition switch is turned to "ON", it interrupts the function of the Immobilizer lamp and a start enable lamp comes "ON". The length of time the lamp remains for depends on the control unit settings.

The diagnostic LED is normally mounted on the instrument panel and receives its power supply directly from the battery. It is controlled by the injection electronic control unit via a negative signal. If the LED is extinguished, irrespective of the position of the ignition switch and/or the instrument panel does not initialise, check: - that the emergency stop button functions correctly; - the connection line used to manage the diagnostic LED, between the injection electronic control unit and the instrument panel; - the connection line between the injection electronic control unit and the emergency stop switch.

NOTE: CONSULT THE SPECIFIC ELECTRICAL CIRCUIT DIAGRAM FOR THE VEHICLE WHEN CARRYING OUT THE FOLLOWING OPERATIONS

Emergency stop button check

1. Disconnect the emergency stop button electrical connector and carry out a continuity check on the connection lines to the injection electronic control unit; 2. Carry out a continuity check on the connection line between emergency stop button and ground. 3. Using a multimeter, check that the emergency stop button functions correctly; connect the terminals of the multimeter between the two pins on the switch that are connected to ground and the injection electronic control unit. Press the button and check that it functions correctly.

Electronic injection control unit check

1. Disconnect the connector from the injection electronic control unit. 2. Make sure that the connection line between the injection electronic control unit and the instrument panel (diagnostic LED management line) is not shorted to the battery. 3. Carry out a continuity test on the connection line between the injection electronic control unit and the instrument pane (diagnostic LED management line).

If no faults are found, replace the injection electronic control unit.

Instrument panel check

1. Disconnect the instrument panel electrical connector. 2. Make sure that the connection line between the injection electronic control unit and the instrument panel (diagnostic LED management line) is not shorted to the battery. 3. Carry out a continuity test on the connection line between the engine electronic control unit and the instrument pane (diagnostic LED management line).

If no other faults are found, replace the instrument panel.

After removing the leg shield back plate, remove the electrical connection from the antenna as shown in the picture.

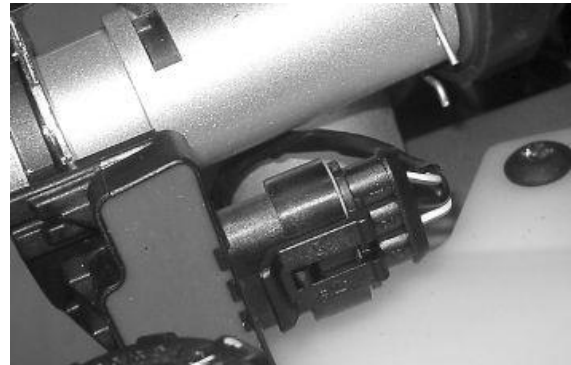

Remove the protective base from the connector.



With the ignition switch at ON check there is battery voltage between the Red-White and Black cables

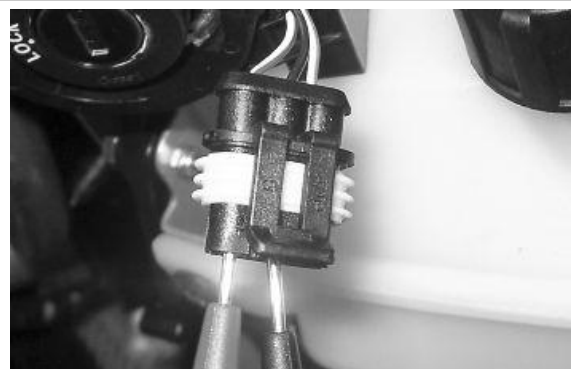

Virgin circuit

When the ignition system is not encrypted, any key will start the engine but limited to 2,000 rpm. The keys can only be recognised if the control unit has been programmed properly.

The data storage procedure for a previously unprogrammed control unit provides for the recognition of the red key (master key) as the first key to be stored to memory: this becomes particularly important because it is the only key that enables the control unit to be wiped clean and reprogrammed for the memorisation of the service keys.

The Master and service keys must be used to code the system as follows:

- Insert the Master key, turn it to «ON» and keep this position for two seconds (lower and upper limits 1 - 3 seconds).
- Insert the blue key and set to «ON» for 2 seconds.
- If you have copies of the key, repeat the operation with each key.
- Insert the MASTER key again and turn it to «ON» for 2 seconds.

The maximum time to change keys is 10 seconds. A maximum of 7 service keys (blue) can be programmed at one time.

It is essential to adhere to the times and the procedure. If you do not, start again from the beginning.

Once the system has been programmed, master key transponder, decoder and control unit are strictly matched.

With this link established, it is now possible to encode new service keys, in the event of losses, replacements, etc.

Each new programming deletes the previous one so, in order to add or eliminate keys, you must re-

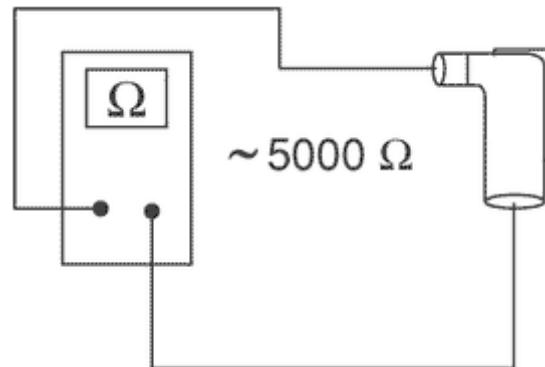

peat the procedure using all the keys you intend to keep using.

If a service key becomes uncoded, the efficiency of the high voltage circuit shielding must be thoroughly inspected. In any case it is advisable to use resistive spark plugs.

Characteristic

Shielded cap resistance

~ 5,000 Ω

Diagnostic codes

The Immobilizer system is tested each time the Ignition switch is turned from «OFF» to «ON». During this diagnosis phase a number of control unit statuses can be identified and various light codes displayed. Regardless of the code transmitted, if at the end of the diagnosis the LED remains off permanently, the ignition is enabled. If, however, the LED remains on permanently, it means the ignition is inhibited:

1. Previously unused control unit - key inserted: a single 2 second flash is displayed, after which the LED remains off permanently. The keys can be stored to memory, the vehicle can be started but with a limitation imposed on the number of revs.

2. Previously unused control unit - transponder absent or cannot be used: the LED is on permanently. In this condition no operations are possible including the start up of the vehicle.

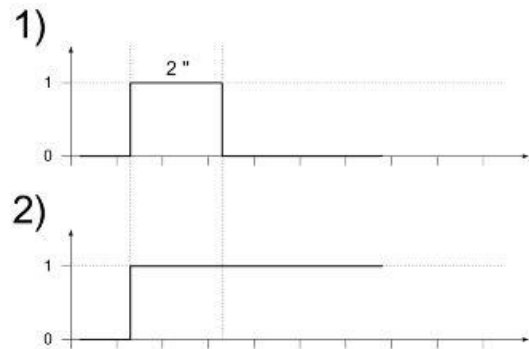

3. Programmed control unit - the service key in (normal condition of use): a single 0.7-second flash is displayed, after which the LED remains off steadily. The engine can be started.

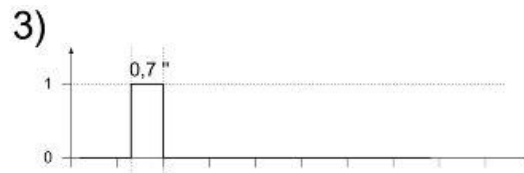

4. Programmed control unit - Master key in: a 0.7-sec flash is displayed followed by the LED remaining off for 2 sec and then by short 0.46-sec flashes, the same number of times as there are keys stored in the memory including the Master key. When the diagnosis has been completed, the LED remains permanently OFF. The engine can be started.

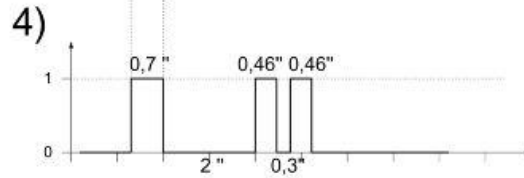

5. Programmed control unit - fault detected: a light code is displayed according to the fault detected, after which the LED remains on steadily. The engine cannot be started. The codes that can be transmitted are:

- 1-flash code
- 2-flash code
- 3-flash code

Diagnostic code - 1 flash

A one-flash code indicates a system where the serial line is not present or is not detected. Check the Immobilizer antenna wiring and change it if necessary.

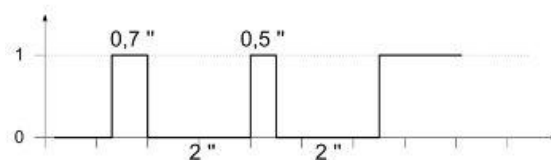

Diagnostic code - 2 flashes

A two-flash code shows a system where the control unit does not show the transponder signal. This might depend on the inefficiency of the Immobilizer antenna or the transponder.

Turn the switch to ON using several keys: if the code is repeated even with the Master key, check the antenna wiring and change it if necessary. If this is not the case, replace the defective key and/or reprogram the control unit. Replace the control unit if the problem continues.

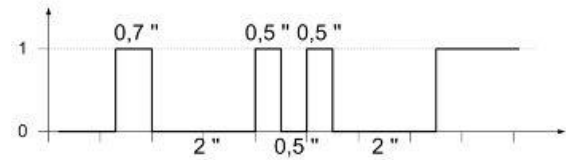

Diagnostic code - 3 flashes

A three-flash code indicates a system where the control unit does not recognise the key. Turn the switch to ON using several keys: if the error code is repeated even with the Master key, replace the control unit. If this is not the case, reprogram the decoder.

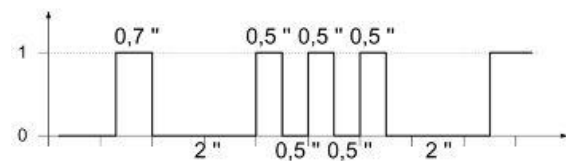

Battery recharge circuit

The charging circuit consists of three-phase alternator and a permanent magneto flywheel.

The alternator is directly connected to the voltage regulator.

This, in its turn, is connected directly to the ground and the battery positive terminal passing through the 30A protective fuse.

The three-phase alternator provides good recharge power and at low revs a good compromise is achieved between generated power and idle stability.

Stator check

Checking the stator windings

WARNING

THE CHECK-UP CAN BE MADE WITH THE STATOR PROPERLY INSTALLED.

- 1) To access the connector remove the footrest.
- 2) Disconnect the connector between stator and regulator with the three yellow cables as shown in the picture.

3) Measure the resistance between each of the yellow terminals and the other two.

Electric characteristic

Resistance:

0.2 - 1 Ω

- 4) Check that there is insulation between the each yellow cable and the ground.
- 5) If the values are incorrect, replace the stator.



Recharge system voltage check

Look for any leakage

- 1) Access the battery by removing the cover in the footrest.
- 2) Check that the battery does not show signs of losing fluid before checking the output voltage.
- 3) Turn the ignition key to position OFF, connect the terminals of the tester between the negative pole (-) of the battery and the black cable and only then disconnect the black cable from the negative pole (-) of the battery.
- 4) With the ignition key always at OFF, the reading indicated by the ammeter must be ≤ 0.5 mA.

Charging current check

WARNING

BEFORE CARRYING OUT THE CHECK, MAKE SURE THAT THE BATTERY IS IN GOOD WORKING ORDER.

- 1) Place the vehicle on its centre stand.
- 2) With the battery correctly connected to the circuit, place the multimeter leads between the battery terminals..
- 3) Start the engine, ensure that the lights are all out, increase the engine speed and at the same time measure the voltage.

Electric characteristic

Voltage ranging between 14.0 and 15.0V at 5,000 rpm.

Maximum current output check

- With engine off and panel set to "ON" turn on the lights and let the battery voltage set to 12V.
 - Connect ammeter clamp to the 2 recharge positive poles in output from the regulator.
 - Keep the lights on and start the engine, bring it to normal speed and read the values on the ammeter.
- With an efficient battery a value must be detected: $> 20A$

VOLTAGE REGULATOR/RECTIFIER

Specification	Desc./Quantity
Type	Non-adjustable three-phase transistor
Voltage	14 - 15V at 5,000 rpm with lights off

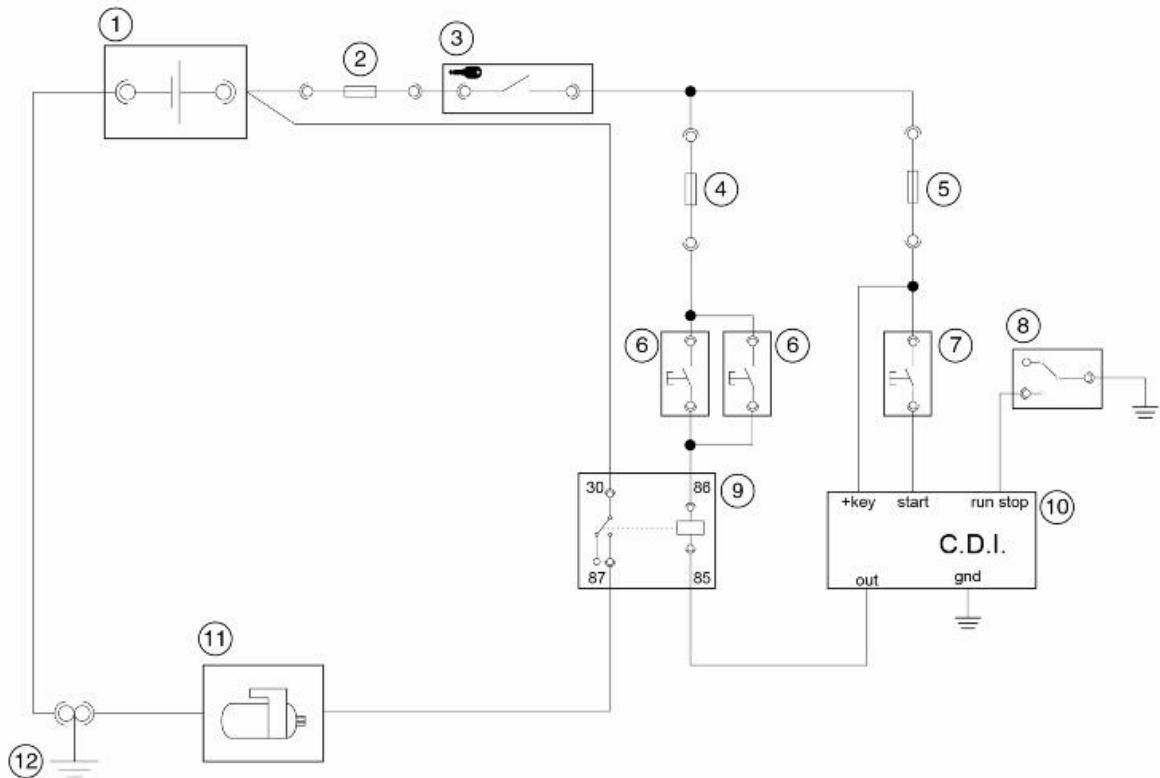
Starter motor**KEY**

1. Battery
2. Fuse n° 1 (30A)
3. Ignition switch
4. Fuse n° 3 (7.5A)
5. Fuse n° 4 (7.5A)
6. Stop buttons
7. Start button
8. Engine stop button
9. Starter relay
10. Electronic injection control unit
11. Starter Motor
12. Ground

WARNING

ALL CONTINUITY TESTS MUST BE CARRIED OUT WITH THE CORRESPONDING CONNECTORS DISCONNECTED.

- 1) Check fuses No. 1,3 and 4.
- 2) Check ignition switch contacts.
- 3) Check the contacts of the stop buttons and the starter button.
- 4) With the ignition switch «ON86 », brake engaged and start button pressed, check for the presence of a voltage between pin 86 of the starter relay and ground; if no voltage is measured, check the wiring harness.
- 5) Check the starter relay.
- 6) Check the continuity of the connection between the battery and the starter relay. Also, check continuity between the latter and the starter motor.
- 7) Check the starter motor ground connection.
- 8) Check the continuity of the connection between pin 85 on the starter relay and pin 10 on the injection electronic control unit.
- 9) Check the contacts on the engine stop switch and the continuity of the connection to pin 4 on the injection electronic control unit.
- 10) Check the engine stop switch ground connection.

Horn control

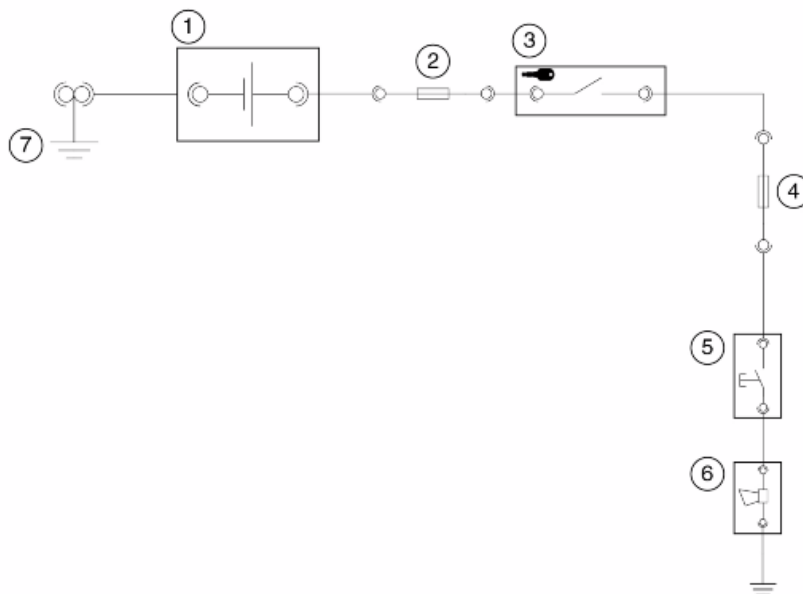

KEY

1. Battery
2. Fuse n° 1 (30A)
3. Ignition switch

4. Fuse n° 3 (7.5A)
5. Horn button
6. Horn
7. Ground

WARNING

ALL CONTINUITY TESTS MUST BE CARRIED OUT WITH THE CORRESPONDING CONNECTORS DISCONNECTED.

- 1) Check fuses No. 1 and 3.
- 2) Check the ignition switch and horn button contacts.
- 3) With the ignition switch set to «ON1 » and the horn button pressed, check if there is voltage between pin 1 on the horn device and the ground connection. If there is not, check the wiring harnesses.
- 4) Check the horn device ground connection.

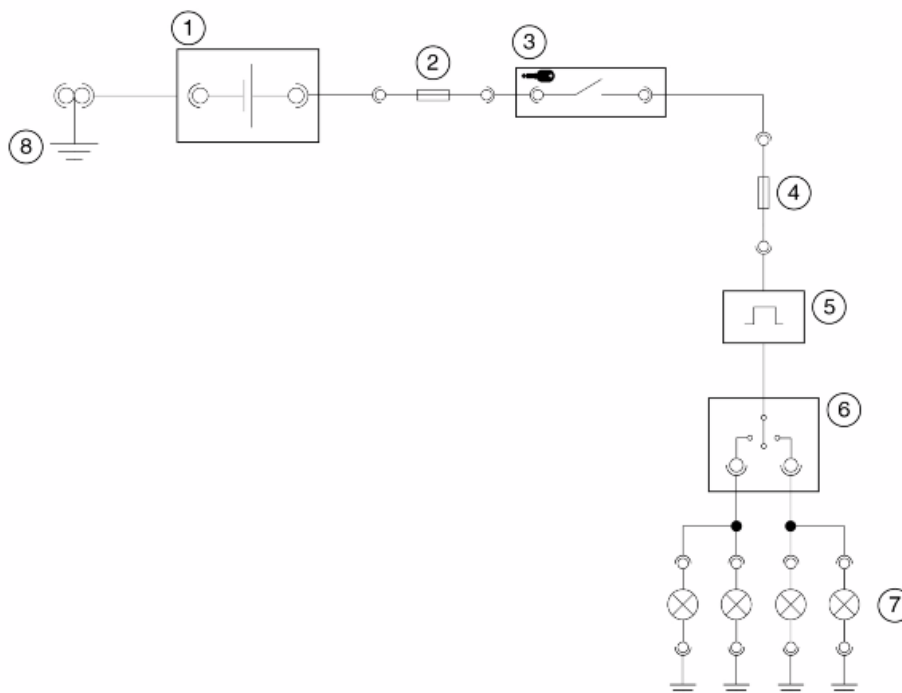
Turn signals system check**KEY**

1. Battery
2. Fuse n° 1 (30A)
3. Ignition switch
4. Fuse n° 3 (7.5A)
5. Turn indicator control device
6. Turn signal switch
7. Turn indicator bulbs

WARNING

ALL CONTINUITY TESTS MUST BE CARRIED OUT WITH THE CORRESPONDING CONNECTORS DISCONNECTED.

- 1) Check that bulbs operate properly.
- 2) Check fuses No. 1 and 3.
- 3) Check ignition switch contacts.
- 4) With the ignition switch set to «**ON**», check if there is voltage between the indicators switch and ground. If there is not, check the wiring harnesses and the connections to direction indicator control device.
- 5) Check the turn indicator switch contacts.
- 6) With the direction indicator switch pressed to the right, check if there is voltage between the switch output light and ground. If there is not, check the wiring harnesses.
- 7) With the direction indicator switch pressed to the left, check if there is voltage between the switch output light and ground. If there is not, check the wiring harnesses.
- 8) Check that the wiring harnesses of the bulbs and their ground connection are not interrupted.

level indicators

WARNING

ALL CONTINUITY TESTS MUST BE CARRIED OUT WITH THE CORRESPONDING CONNECTORS DISCONNECTED.

If faults are detected:

- 1) Using a multimeter, measure the resistance values between pins 1 and 2 on the fuel level sender in various conditions.
- 2) If the transmitter operates correctly but the indication on the instrument panel is not exact, check that the wiring harnesses between them are not interrupted.

**Electric characteristic****Resistance value with full tank**

$\leq 7 \Omega$

Resistance value with empty tank

$90 + 13/-3 \Omega$

Lights list

EUROPE VERSION**BULBS**

	Specification	Desc./Quantity
1	High beam / low beam bulb	Type: LED

Specification		Desc./Quantity
		Quantity: 2
2	Front daylight running lights	Type: LED
		Quantity: 2
3	Front and rear turn indicator bulbs	Type: Capless
		Power: 12V - 6W
		Quantity: 4
4	Rear tail light bulb	Type: LED
		Quantity: 2
5	Stop light bulb	Type: LED
		Quantity: 1
6	Licence plate light bulb	Type: LED
		Quantity: 2

FOR USA-LATAM VERSION

BULBS

Specification		Desc./Quantity
1	High beam / low beam bulb	Type: LED
		Quantity: 2
2	Front and rear turn indicator bulbs	Type: Capless
		Power: 12V - 10W
		Quantity: 4
3	Rear tail light bulb	Type: LED
		Quantity: 2
4	Stop light bulb	Type: LED
		Quantity: 1
5	Licence plate light bulb	Type: LED
		Quantity: 2

Fuses

FOR SUPERTECH VERSION

The electrical system is equipped with:

1. one fuse «**A**», located in the battery compartment;



2. six protection fuses «**B**» located in the glove compartment to the left;



3. one fuse «C» located under the seat, accessible by extracting the helmet compartment.

The tables show the position and characteristics of the fuses on the vehicle.

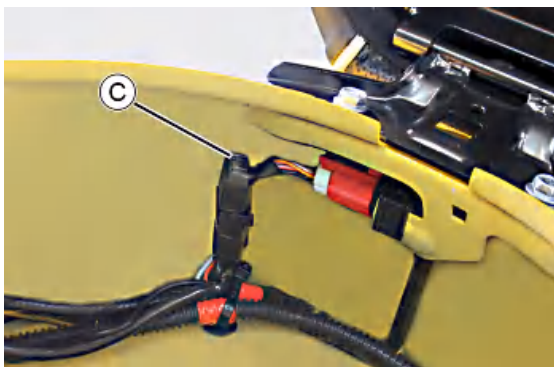

CAUTION



BEFORE REPLACING THE BLOWN FUSE, TRY TO ELIMINATE THE FAULT THAT HAS CAUSED IT TO BLOW. NEVER TRY TO REPLACE A FUSE USING DIFFERENT MATERIAL (FOR EXAMPLE A PIECE OF ELECTRIC WIRE).

CAUTION



MODIFICATIONS OR REPAIRS TO THE ELECTRICAL SYSTEM, PERFORMED INCORRECTLY OR WITHOUT STRICT ATTENTION TO THE TECHNICAL SPECIFICATIONS OF THE SYSTEM CAN CAUSE MALFUNCTIONING AND RISK OF FIRE.

Fuse «A».

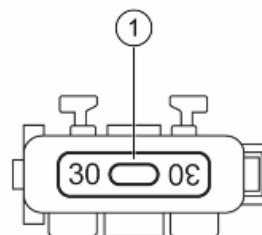

FUSE «A»

	Specification	Desc./Quantity
1	Fuse no. 1	Capacity: 30 A Protected circuits: System general.

Fuse «B».

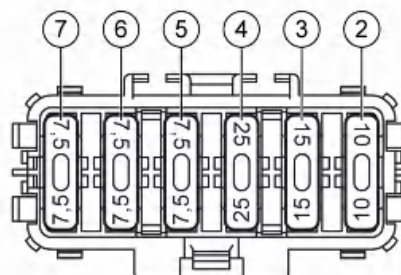

FUSE «B»

	Specification	Desc./Quantity
1	Fuse no. 2	Capacity: 10A Protected circuits: battery-powered, engine control unit, injection load relay, heater.
2	Fuse no. 3	Capacity: 15A

Specification	Desc./Quantity
	Protected circuits: battery powered, electric fan relay (contacts), 5A fuse, instrument cluster, lights relay, provision for accessories, bike finder. Key-powered: Saddle opening actuator.
3 Fuse no. 4	Capacity: 25A Protected circuits: battery-powered, ABS control unit.
4 Fuse no. 5	Capacity: 7.5 A Protected circuits: key-on power for ABS ECU, immobilizer antenna, engine management ECU, injection load relay (coil).
5 Fuse no. 6	Capacity: 7.5 A Protected circuits: key powered, horn, taillight, USB socket, lights relay, turn signal flasher unit, provision for accessories, bike finder.
6 Fuse no. 7	Capacity: 7.5 A Protected circuits: key powered, front indicators, «Vespa MIA» device, diagnostics socket, rear position light.

Fuse «C».

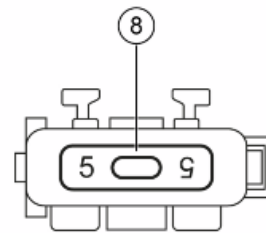

FUSE «C»

Specification	Desc./Quantity
1 Fuse no. 8	Capacity: 5A Protected circuits: 15A fuse powered, diagnostics socket.

In this section are listed the bulb types for the vehicle fitting.

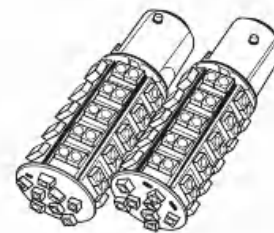

EUROPE VERSION

BULBS

Specification	Desc./Quantity
1 High beam / low beam bulb	Type: LED Quantity: 2
2 Front daylight running lights	Type: LED Quantity: 2
3 Front and rear turn indicator bulbs	Type: Capless Power: 12V - 6W Quantity: 4
4 Rear tail light bulb	Type: LED Quantity: 2
5 Stop light bulb	Type: LED Quantity: 1
6 Licence plate light bulb	Type: LED

Specification	Desc./Quantity
---------------	----------------

FOR USA-LATAM VERSION

BULBS

Specification	Desc./Quantity
1	High beam / low beam bulb Type: LED Quantity: 2
2	Front and rear turn indicator bulbs Type: Capless Power: 12V - 10W Quantity: 4
3	Rear tail light bulb Type: LED Quantity: 2
4	Stop light bulb Type: LED Quantity: 1
5	Licence plate light bulb Type: LED Quantity: 2

The electrical system is equipped with:

1. one fuse «**A**», located in the battery compartment;



2. six protection fuses «**B**» located in the glove compartment to the left;



3. one fuse «**C**» located under the seat, accessible by extracting the helmet compartment.

The tables show the position and characteristics of the fuses on the vehicle.

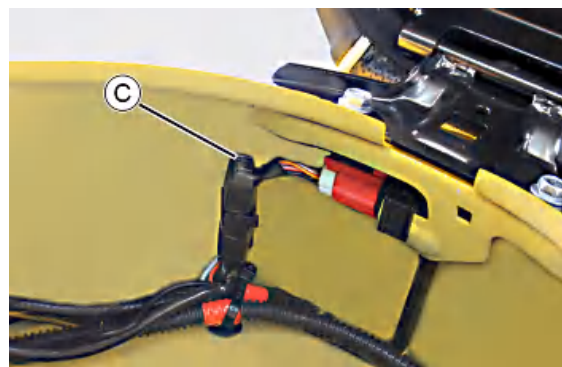

CAUTION



BEFORE REPLACING THE BLOWN FUSE, TRY TO ELIMINATE THE FAULT THAT HAS CAUSED IT TO BLOW. NEVER TRY TO REPLACE A FUSE USING DIFFERENT MATERIAL (FOR EXAMPLE A PIECE OF ELECTRIC WIRE).

CAUTION



MODIFICATIONS OR REPAIRS TO THE ELECTRICAL SYSTEM, PERFORMED INCORRECTLY OR WITHOUT STRICT ATTENTION TO THE TECHNICAL SPECIFICATIONS OF THE SYSTEM CAN CAUSE MALFUNCTIONING AND RISK OF FIRE.

Fuse «A».

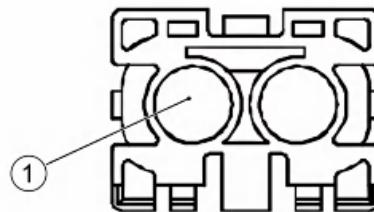

FUSE «A»

	Specification	Desc./Quantity
1	Fuse no. 1	Capacity: 30 A Protected circuits: System general.

Fuse «B».

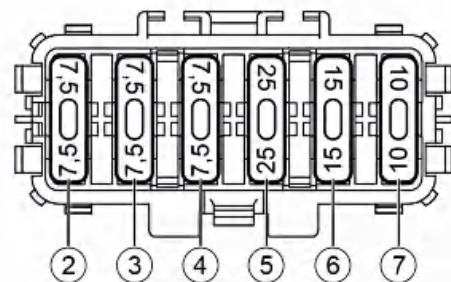

FUSE «B»

	Specification	Desc./Quantity
1	Fuse no. 2	Capacity: 7.5 A Protected circuits: key power supply, position lights, instrument panel, taillight, diagnostics socket.
2	Fuse no. 3	Capacity: 7.5 A Protected circuits: key powered, horn, taillight, USB socket, lights relay, turn signal flasher unit, provision for accessories, bike finder.
3	Fuse no. 4	Capacity: 7.5 A Protected circuits: key power supply, immobilizer antenna, engine management ECU, tilting sensor, ABS control unit, injection load coil.
4	Fuse no. 5	Capacity: 25A Protected circuits: battery-powered, ABS control unit.
5	Fuse no. 6	Capacity: 15A Protected circuits: battery powered, electric fan relay (contacts), 5A fuse, instrument cluster, lights relay, provision for accessories, bike finder. Key-powered: Saddle opening actuator.
6	Fuse no. 7	Capacity: 10A Protected circuits: battery-powered, engine control unit, injection load relay, heater.

Fuse «C».

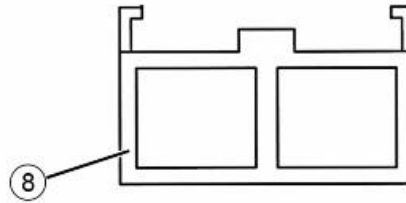

FUSE «C»

	Specification	Desc./Quantity
1	Fuse no. 8	Capacity: 5A Protected circuits: 15A fuse powered, diagnostics socket.

Dashboard

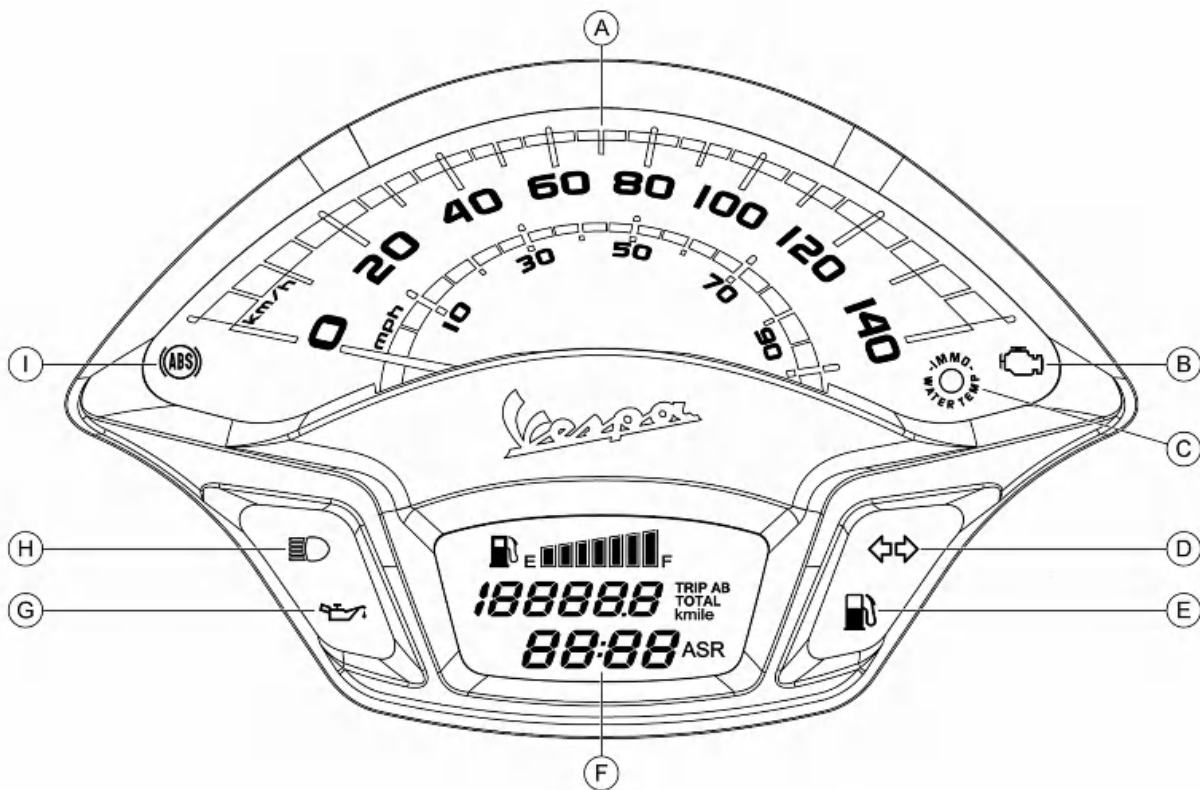

- A = Speedometer
- B = Engine control warning light
- C = Immobilizer / Engine temperature warning lamp
- D = Turn indicator warning light
- E = Low fuel warning light
- F = Digital display
- G = Low engine oil pressure warning light

H = High beam warning light

I = ABS warning light

Sealed battery

If the vehicle is provided with a sealed battery, the only maintenance required is the check of its charge and recharging, if necessary.

These operations should be carried out before delivering the vehicle, and on a six-month basis while the vehicle is stored in open circuit.

Besides upon pre-delivery it is therefore necessary to check the battery charge and recharge it, if required, before storing the vehicle and afterwards every six months.

INSTRUCTIONS FOR BATTERY REFRESH AFTER OPEN CIRCUIT STORAGE

1) Voltage check

Before installing the battery on the vehicle, check the open circuit voltage with a standard tester.

- If voltage exceeds 12.60 V, the battery can be installed without any renewal recharge.
- If voltage is below 12.60 V, a renewal recharge is required as explained in 2).

2) Constant voltage battery charge mode

- Constant voltage charge equal to 14.40 - 14.70V
- Initial charge voltage equal to 0.3 - 0.5 for Nominal capacity
- Charge time:
10 - 12 h recommended
Minimum 6 h
Maximum 24 h

3) Constant current battery charge mode

- Charge current equal to 1/10 of the battery rated capacity
 - Charge time: Maximum 5 h
-

Battery installation

VRLA battery (valve-regulated lead-acid battery) Maintenance Free (MF)

WARNING

BATTERY ELECTROLYTE IS TOXIC AND IT MAY CAUSE SERIOUS BURNS. IT CONTAINS SULPHURIC ACID. AVOID CONTACT WITH EYES, SKIN AND CLOTHING. IF IT ACCIDENTALLY COMES INTO CONTACT WITH YOUR EYES OR SKIN, WASH WITH ABUNDANT WATER FOR APPROX. 15 MIN. AND SEEK IMMEDIATE MEDICAL ATTENTION.

IN THE EVENT OF ACCIDENTAL INGESTION OF THE LIQUID, IMMEDIATELY DRINK LARGE QUANTITIES OF WATER OR MILK. MAGNESIUM MILK, BATTERED EGG OR VEGETABLE OIL. SEEK IMMEDIATE MEDICAL ATTENTION.

BATTERIES PRODUCE EXPLOSIVE GAS; KEEP CLEAR OF NAKED FLAMES, SPARKS OR CIGARETTES; VENTILATE THE AREA WHEN RECHARGING INDOORS.

ALWAYS WEAR EYE PROTECTION WHEN WORKING IN THE PROXIMITY OF BATTERIES. KEEP OUT OF THE REACH OF CHILDREN.

1) Battery preparation

Position the battery on a flat surface. Remove the adhesive sheet closing cells and proceed as quickly as possible to run the subsequent activation phases.

**2) Electrolyte preparation.**

Remove the container of the electrolyte from the pack. Remove and preserve cover strips from the container, in fact, the strip will later be used as a closing cover.

Note: Do not pierce the sealing of the container or the container itself because inside there is sulphuric acid.

**3) Procedure for filling the battery with acid.**

Position the electrolyte container upside down with the six areas sealed in line with the six battery filler holes. Push the container down with enough force to break the seals. The electrolyte should start to flow inside the battery.

Note: Do not tilt the container to prevent the flow of electrolyte from pausing or stopping.

**4) Control the flow of electrolyte**

Make sure air bubbles are rising from all six filling holes. Leave the container in this position for 20 minutes or more.

Note: If there are no air bubbles coming out of the filling holes, lightly tap the bottom of the container two or three times. Do not remove the container from the battery.

5) Take out the container.

Make sure all the electrolyte in the battery is drained. Gently tap the bottom of the container if electrolyte remains in the container. Only once the container is completely empty, gently remove the container itself from the battery. Leave the battery to rest, without sealing the six cells, for at least 1 hour before charging.

6) Recharging the new battery

With the above-mentioned procedure, the battery will have gained around 70% - 75% of its total electrical capacity. Before installing the battery on the vehicle, it must be fully charged and then must be recharged.

If the battery is to be installed on the vehicle prior to this pre-charged one, the battery will not be able to exceed 75% charge without jeopardising its useful life on vehicle.

The dry charge battery MF like the completely loaded YTX, must have a zero load voltage between 12.8 - 13.15 V Bring the battery to full charge, using the 020648Y battery charger:

- a - select the type of battery with the red switch on the left of the panel battery charger panel
- b - select NEW on the yellow timer
- c - connect the clamps of the battery charger to the battery poles (black clamp to negative pole (-) and red clamp to positive pole (+)).

- d - Press the red button, as shown in figure.

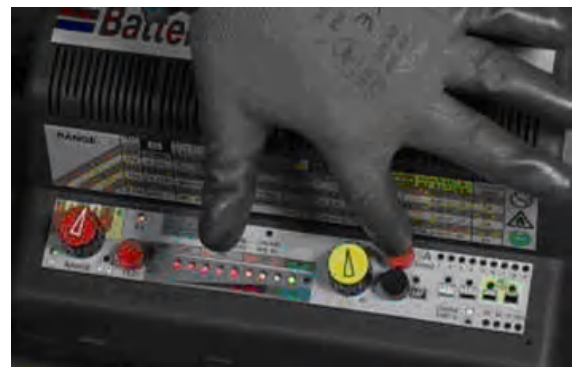

- e - Press the "MF" black button to activate the battery recharge **Maintenance Free** as shown in figure.



f - Check the ignition of the green LED indicated with a red arrow in figure.



g - The activation cycle of the new battery lasts for 30 minutes after the ignition of the recharge LED has taken place



h - Disconnect the clamps from the battery and check the voltage, if voltages are detected of less than 12.8 V, proceed with a new recharge of the battery starting from point c of the recharge procedure of **the new battery**, otherwise go to point i



i - The battery is now properly activated, disconnect the battery charger from the power supply and unplug the terminals from the battery.

7) Battery closing.

Insert the airtight cover strips into the filling holes.

Press horizontally with both hands and make sure that the strip is levelled with the top part of the battery.

Note: To do this, do not use sharp objects that could damage the closing strip, use gloves to protect your hands and do not bring your face close to the battery.

The filling process is now complete.

Do not remove the strip of caps under any circumstances, do not add water or electrolyte.

Assembly procedure of the battery on the vehicle.

Connectors

FOR SUPERTech VERSION

The list, in alphabetical order, of the vehicle's electrical components is provided below:

- Immobilizer antenna
- Engine stop
- Saddle opening actuator
- Bike Finder
- Blinker
- H.V. coil
- Starter relay coil
- ABS control unit
- MIUG4 control unit
- Horn
- Ignition switch
- Turn signal switch
- Starter relay contact
- Light switch
- Electric fan
- Taillight
- OBD socket fuse
- Main fuse
- Instrument cluster
- Right turn indicator and parking light
- Left turn indicator and parking light
- Rear right turn indicator
- Rear left turn indicator
- Fuel level indicator
- Injector
- Joystick
- Frame ground
- Battery negative
- Pick-up /oil pressure sensor
- Fuel pump
- Fuse box
- Battery positive
- Accessories pre-installation
- PMP2 pre-installation
- OBD port
- USB port

- Headlight
- Saddle release switch
- ASR Button
- Stand button
- Horn button
- Start button
- RH brake light button
- LH brake light button
- Voltage regulator
- Front ABS sensor
- Rear ABS sensor
- Roll-over sensor
- Air temperature sensor
- Engine temperature sensor
- Lambda probe with heater
- Injection load relay
- Electric fan contactor
- Light relay

Immobilizer antenna

1. (Red/White) Key-on power supply input
2. (Black) Ground
3. (Orange/White) - "ENABLE" signal output for MIG4 control unit

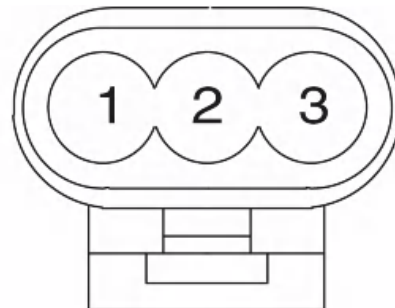

Engine stop

- A. Not connected
- B. (Grey / Green) Signal output for MIUG4 control unit
- C. (Green//Black) Ground reference from the MIUG4 control unit

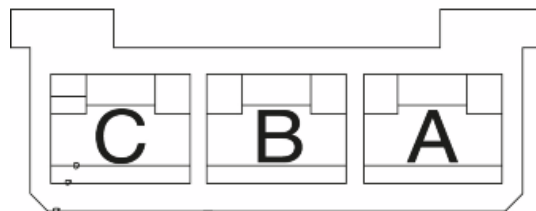

Saddle opening actuator

-)1. (Black) Ground
- 2. (Blue) Saddle release signal input

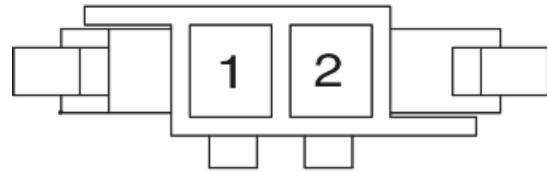

Bike Finder

-)1. (Grey) Battery power supply input
- 2. (White) Key on power supply input
- 3. (Black) Ground
- 4. (Pink) Left hand turn indicator lights signal output
- 5. (Blue) Saddle release signal input
- 6. (White/Blue) Right hand turn indicator lights signal output

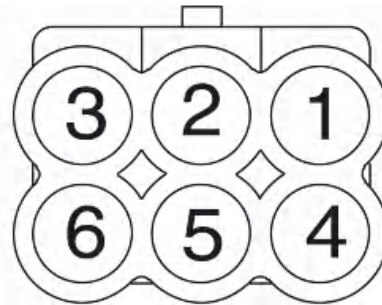

Blinker

- L. (Blue/Black) Signal output for flashers switch
- B. (White) Key on power supply input

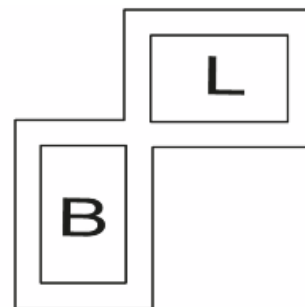

H.V. coil

-)1. (Pink / Black) Signal input (-) from the MIUG4 control unit
- 2. (Black/Green) Power supply input from injection load relay

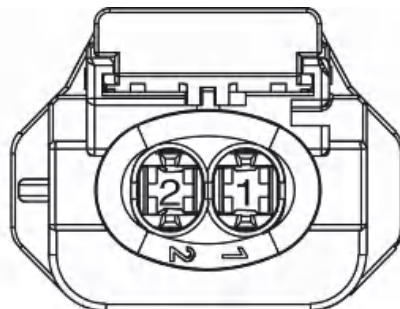

Starter relay coil

- (White/Black) Key-on power supply input from STOP buttons (right and/or left)

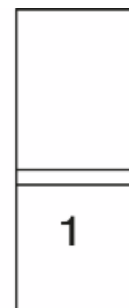

Starter relay coil

- (Orange / Blue) Signal input (-) from the MIUG4 control unit

**ABS control unit**

- 1. Not connected
- 2. (Pink/Red) CAN H line
- 3. (Blue/Green) - ABS indicator lamp command signal (-) output
- 4. (Red/White) Key-on power supply input
- 5. (Orange/Black) K line
- 6. (Brown/Red) Rear wheel sensor signal input
- 7. Not connected
- 8. (Light blue/Red) Front wheel sensor signal input
- 9. Not connected
- 10. (Black) Ground
- 11. (Pink/White) CAN L Line
- 12. Not connected
- 13. (Light blue) Vehicle speed signal output
- 14. (Black) PCC ground_2
- 15. (Brown/Black) Ground reference for rear wheel sensor
- 16. (Black) PCC ground_1
- 17. (Light blue/Black) Ground reference for front wheel sensor
- 18. (Grey/Red) Battery power supply input

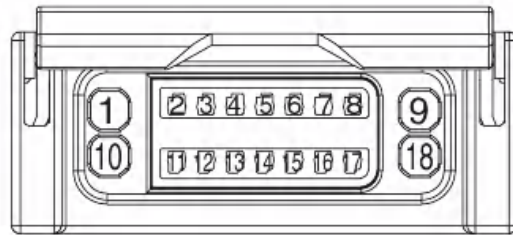
**MIUG4 control unit**

- 1. (Pink/Black) H.V. coil signal output (-)
- 2. Not connected
- 3. (Blue/Brown) ASR warning light command signal output
- 4. (Green/Black) Signal input (-) from engine stop button

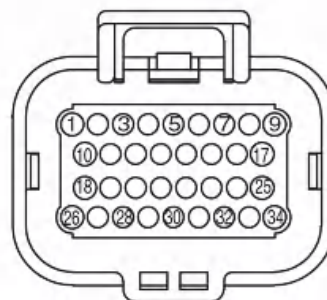

5. (Brown/Red) Signal input (+) from the start button
6. (Red/White) Key-on power supply input
7. (Black) Power ground
8. Not connected
9. (White/Black) Battery power supply input
10. (Orange/Blue) Starter relay coil command signal output (-)
11. (Light blue/Black) Lambda probe (+)
12. (White/Green) Lambda probe (-)
13. (Light blue/Green) Engine temperature sensor signal input
14. (Orange/White) "ENABLE" signal input from the immobilizer antenna
15. (Grey/Green) Sensor ground reference
16. Not connected
17. (Red/Green) Immobilizer warning light control signal output (-)
18. (Grey/Black) Tilting sensor signal input
19. (Brown/Red) Signal input (-) from the stand button
20. (Brown) Pickup (-)
21. (Light blue/White) Signal input (-) from the ASR button
22. (Black/Purple) Injection loads coil command signal output (-)
23. (Black) Power ground
24. (Blue/Yellow) Electric fan relay coil command signal output (-)
25. Not connected
26. (Pink/Red) CAN H line
27. (Pink/White) CAN L Line
28. Not connected
29. (Red) Pickup (+)
30. Not connected
31. (Light blue/red) Ground reference for lambda probe heater
32. Not connected

33. (Purple/White) Lights relay coil command signal output (-)

34. (Red/Yellow) Injector command signal output (-)

Horn

- (Yellow/Pink) Signal (+) input from horn button

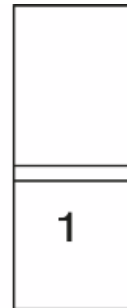

Horn

- (Black) Ground

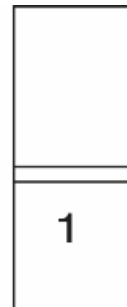

Ignition switch

- 1. (Grey) Battery power supply input
- 2. Not connected
- 3. (Blue / Black) Key on power supply output for the saddle release button
- 4. (Orange) Key on power supply output
- 5. (Red/Black) - Battery power supply input

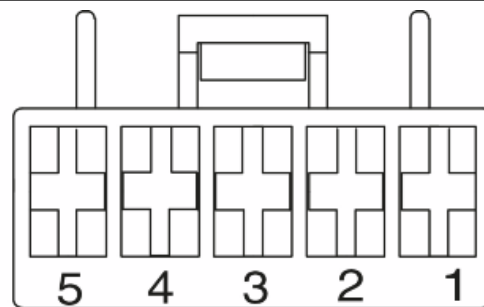

Turn signal switch

- A. (Pink) Signal output from left hand flashers
- B. (Blue/Black) - Signal input from Blinker
- C. (White/Blue) Signal output from right hand flashers

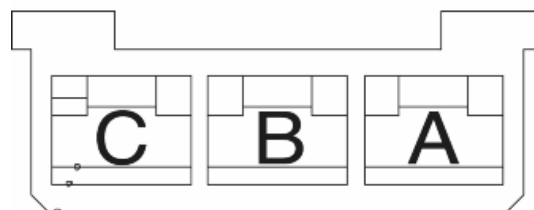

Starter relay contact

- (Red) Battery power supply input

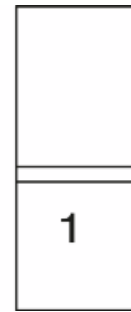

Light switch

A. (Grey / Red) Power input from the lights relay contact

B. (Brown) Low beam lights activation signal output

C. (Purple) High beam lights activation signal output

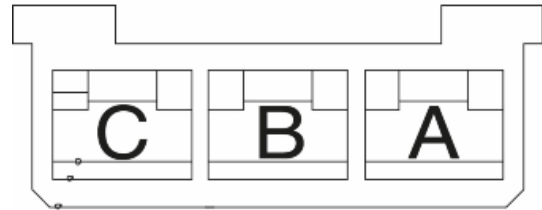

Electric fan

1. (Black) Ground

2. (Red) Power supply input from electric fan relay contact

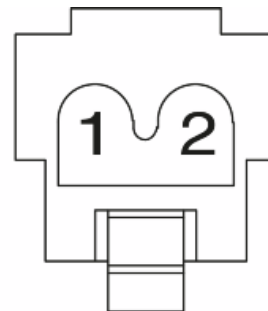

Taillight

1. (Yellow/Black) Key on power supply for position lights activation

2. (Black) Ground

3. (White/Black) Brake light activation signal (+) input

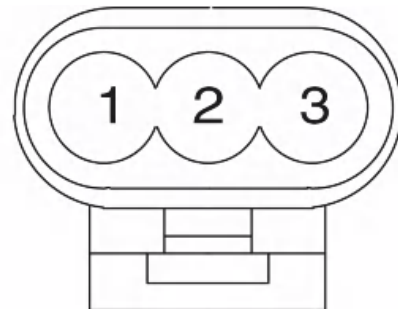

OBD socket fuse

1. (Red / Yellow) Power supply output for OBD socket

2. (Grey) Battery power supply input

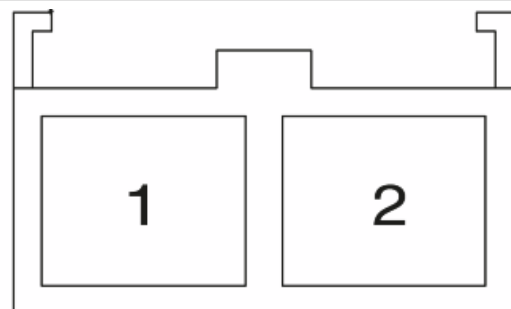

Main fuse

1. (Red) Battery power input
2. (Red/Black) Battery power supply output

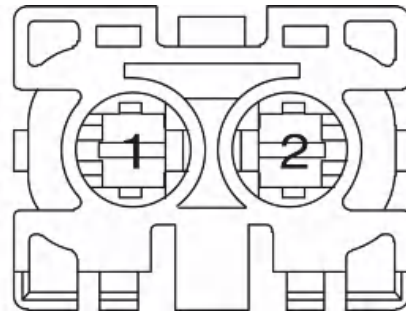
**Instrument cluster**

1. Not connected
2. Not connected
3. Not connected
4. (White/Green) - Fuel level signal input
5. (Red/Yellow) - Air temperature signal input
6. (Blue/White) - UP signal input from Joystick
7. Not connected
8. Not connected
9. (Grey) - Battery power supply input
10. Not connected
11. (Green) - DOWN signal input from Joystick
12. (Red) - PUSH signal input from Joystick
13. (Pink / Green) - Engine oil pressure indicator light command signal input
14. (Purple) - High beam indicator light command signal input
15. (Blue) - ABS indicator light control signal input
16. (Yellow/Black) - Key on power supply input
17. (Grey) - Battery power supply input
18. (Light blue) - Vehicle speed signal input
19. (White/Blue) - Right hand turn signal indicator lamp command signal input
20. (Pink) - Left hand turn signal indicator lamp command signal input
21. (Red/Green) Immobilizer indicator light control signal input
22. (Yellow) - RIGHT signal input from Joystick
23. (White) - LEFT signal input from Joystick
24. (Black) - Ground
25. (Black) - Ground

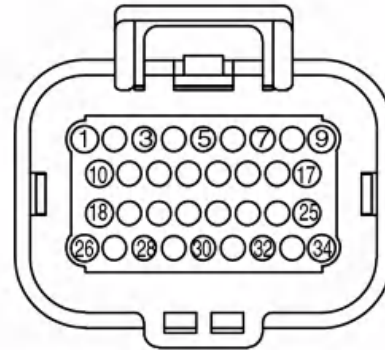

- 26. Not connected
- 27. Not connected
- 28. Not connected
- 29. (Blue/Brown) - ASR indicator light command signal input
- 30. Not connected
- 31. (Grey / Red) - Motor temperature signal input
- 32. (Pink/White) - CAN L
- 33. (Pink/Red) - CAN H
- 34. Not connected

Right turn indicator and parking light

- 1. (White/Blue) Turn indicator activation signal input (+)
- 2. (Yellow/Black) Parking light activation signal input (+)
- 3. (Black) Ground

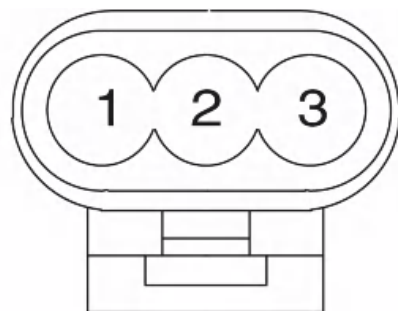

Left turn indicator and parking light

- 1. (Pink) Turn indicator light activation signal input (+)
- 2. (Yellow/Black) Parking light activation signal input (+)
- 3. (Black) Ground

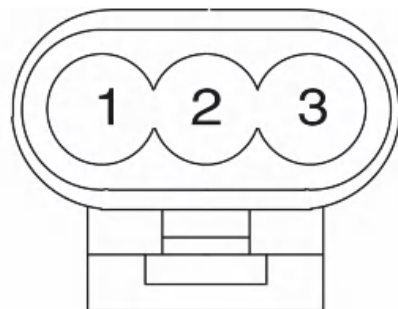

Rear right turn indicator

- 1. (Black) Ground
- 2. (White/Blue) Turn indicator activation signal input (+)

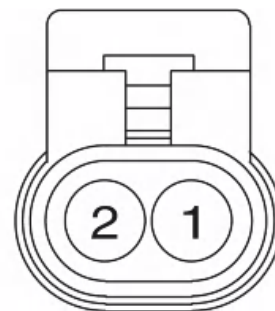

Rear left turn indicator

- 1. (Black) Ground
- 2. (Pink) Turn indicator light activation signal input (+)

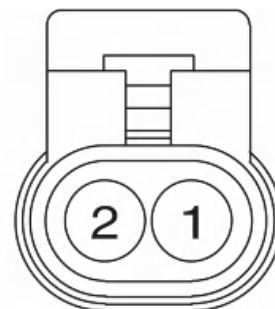

Fuel level indicator

- 1. (White/Green) Fuel level signal output
- 2. (Black) Ground
- 3. Not connected

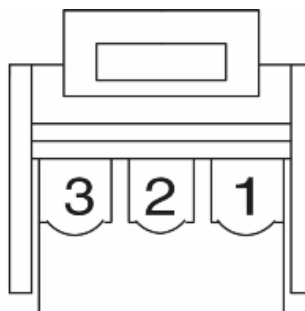
**Injector**

- 1. (Black/Green) Power supply input from injection load relay
- 2. (Red/Yellow) Signal input (-) from the MIUG4 control unit

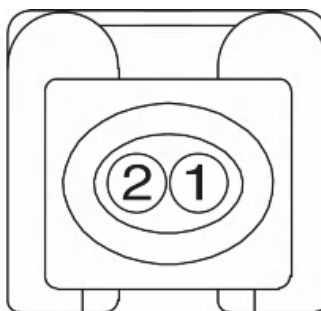
**Joystick**

- 1. (Black) - Ground
- 2. (White) - LEFT signal output
- 3. (Yellow) - RIGHT signal output
- 4. (Green) - DOWN signal output
- 5. (Light blue/White) - UP signal output
- 6. (Red) - PUSH signal output

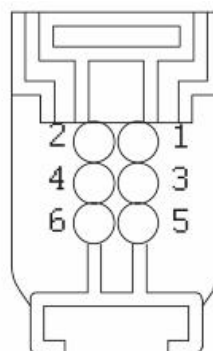
**Frame ground**

- (Black) Direct connection with the battery negative
- (Black) Power ground for vehicle electric devices

**Battery negative**

- (Black) Direct connection with the chassis ground point
- (Black) Direct connection with the voltage regulator



Pickup / Oil pressure sensor

- 1. (Red) Power supply from the MIUG4 control unit
- 2. (Brown) Ground reference from the MIUG4 control unit
- 3. (Pink/Green) Engine oil warning light activation command signal output (-)

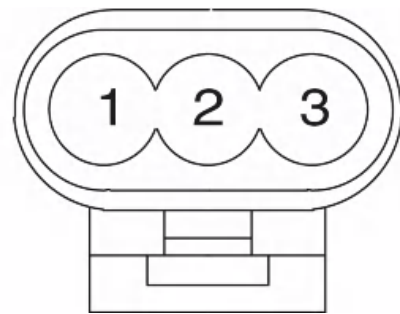

Fuel pump

- 1. (Black) Ground
- 2. (Black/Green) Power supply input from injection load relay

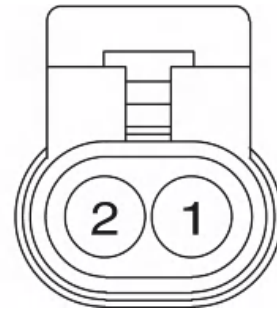

Fuse box

- 1. (White/Black) Battery power supply output from 10A fuse
- 2. (Grey) Battery power supply output from 15A fuse
- 3. (Grey/Red) Battery power supply output from 25A fuse
- 4. (Red/White) Key-on power supply output from 7.5A fuse
- 5. (White) Key-on power supply output from 7.5A fuse
- 6. (Yellow/Black) Key-on power supply output from 7.5A fuse
- 7. (Red/Black) Battery power supply input for 10A fuse
- 8. (Red/Black) Battery power supply input for 15A fuse
- 9. (Red/Black) Battery power supply input for 25A fuse
- 10. (Orange) Key-on power supply input for 7.5A fuse
- 11. (Orange) Key-on power supply input for 7.5A fuse

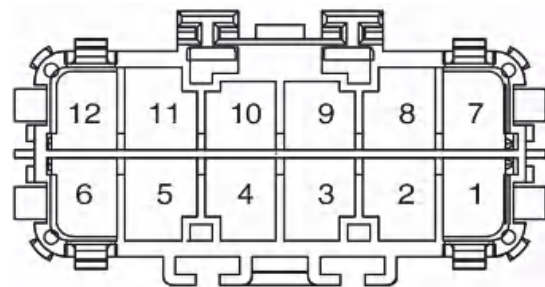

12. (Orange) Key-on power supply input for 7.5A fuse

Battery positive

- (Red) Direct connection with the 30A main fuse
- (Red) Direct connection with starter motor relay contact

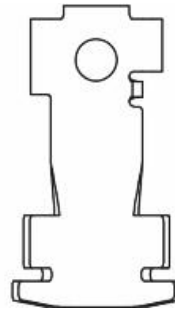

Accessories pre-installation

1. (Black) Ground
2. (White/Green) Fuel level signal
3. (Pink/Red) CAN H line
4. (Pink/White) CAN L Line
5. (Orange/Black) K line
6. Not connected
7. (Grey) Battery power supply input
8. (White) Key on power supply input
9. Not connected
10. (Blue) Saddle release signal
11. (Pink) Left hand turn indicator signal
12. (White/Blue) Right hand turn indicator signal
13. (Purple) High-beam light signal
14. (Light blue) Vehicle speed signal

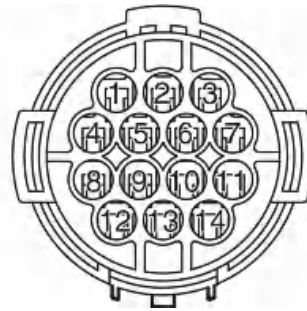

PMP2 pre-installation

1. (Yellow/Black) - Key on power supply input
2. (Black) - Ground
3. (Pink/Red) - CAN H
4. (Pink/White) - CAN L
5. Not connected
6. (White/Green) - Fuel level signal
7. (White/Blue) - Right hand turn indicator signal
8. (Pink) - Left turn indicator signal

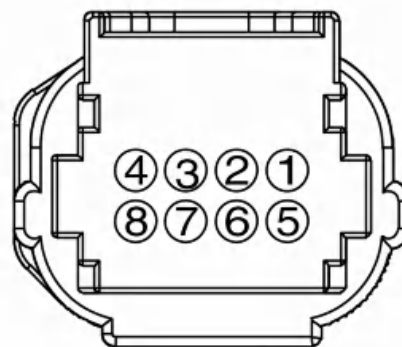

OBD port

-)1. (Yellow/Black) Key on power supply input
- 2. (Pink/Red) CAN H line
- 3. (Black) Ground
- 4. (Red/Yellow) Battery power supply input from the specific protection fuse 5A
- 5. (Pink/White) CAN L Line
- 6. (Orange/Black) K line

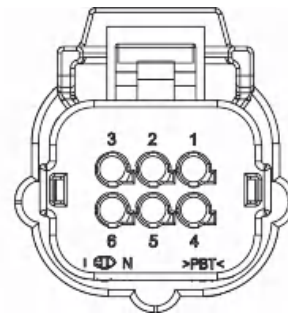

USB port

-)1. (White) Key on power supply input
- 2. (Black) Ground

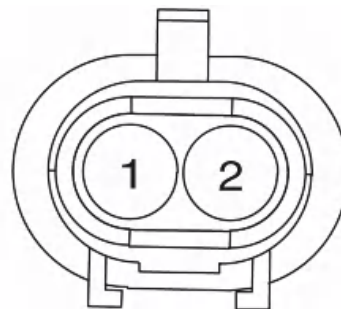

Headlight

-)1. (Brown) Low beam light activation signal input (+)
- 2. (Purple) High beam light signal input (+)
- 3. (Black) Ground

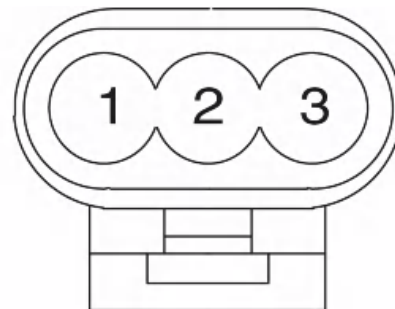

Saddle release switch

-)1. (Blue / Black) Key on power supply input from the ignition switch
- 2. (Blue) Saddle release signal output (+)

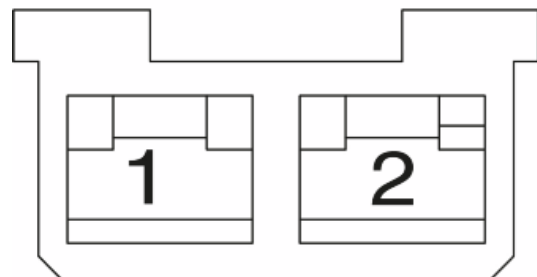

ASR Button

- A. (Grey/Green) Ground reference from the MIUG4 control unit
- B. Not connected
- C. (Light blue/White) Signal output (-) for the MIUG4 control unit

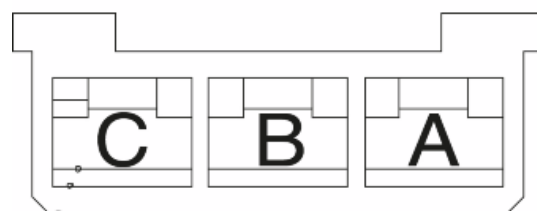

Stand button

- 1. (Brown/Red) Signal output (-) for the MIUG4 control unit
- 2. (Grey/Green) Ground reference from the MIUG4 control unit

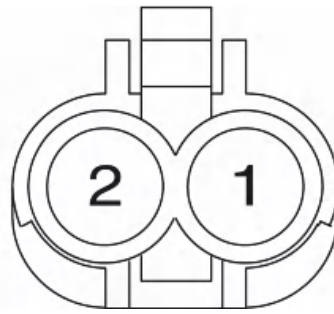
**Horn button**

- 1. (Yellow/Red) Signal output (+) for horn activation
- 2. (White) Key on power supply input
- 3. Not connected

**Start button**

- 1. (Brown/Red) Key on power supply input
- 2. (Red/White) Signal output (+) for the MIUG4 control unit
- 3. Not connected

**RH brake light button**

- (White) Key on power supply input

**RH brake light button**

- (White/Black) Signal output for brake light activation and starter relay coil power supply



LH brake light button

- (White) Key on power supply input



LH brake light button

- (White/Black) Signal output for brake light activation and starter relay coil power supply



Voltage regulator

-)1. (Red/Black) Battery power supply input from the 30A main fuse
- 2. (Black) Direct ground from the battery negative

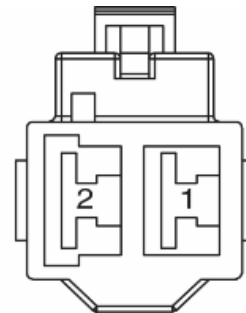

Front ABS sensor

-)1. (Light blue/Black) Ground reference from the ABS control unit
- 2. (Light blue/Red) - Signal output for ABS control unit

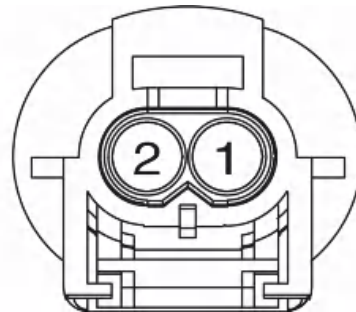

Rear ABS sensor

-)1. (Brown/Black) Ground reference from the ABS control unit
- 2. (Brown/Red) Signal output for the ABS control unit

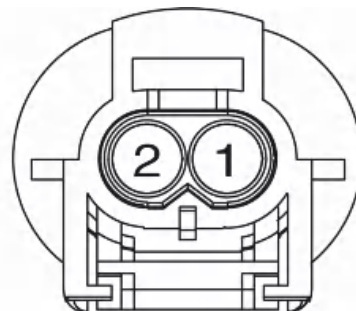

Roll-over sensor

- 1. Not connected
- 2. (Grey/Green) Ground reference from the MIUG4 control unit
- 3. (Red/White) Key-on power supply input
- 4. (Grey / Black) Signal output for the MIUG4 control unit

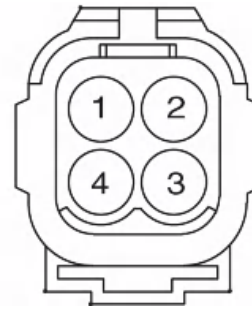
**Air temperature sensor**

- 1. (Black) - Ground
- 2. (Red/Yellow) - Signal output for instrument cluster

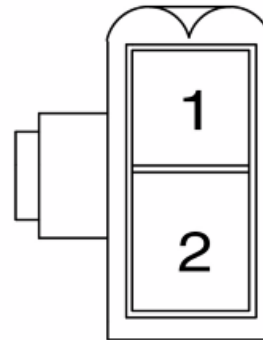
**Engine temperature sensor**

- 1. (Grey/Green) - Ground reference from the MIUG4 control unit
- 2. (Black) - Ground
- 3. (Light blue / Green) - Signal output for the MIUG4 control unit
- 4. (Grey/Red) - Signal output for instrument cluster

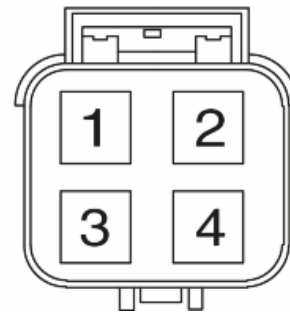
**Lambda probe with heater**

- 1. (Light blue/Black) Power supply from the MIUG4 control unit for the lambda probe
- 2. (White/Green) Ground reference from the MIUG4 control unit for the lambda probe
- 3. (Light blue/Red) Ground reference from the MIUG4 control unit for the heater
- 4. (Black/Green) Power supply input from the injection load relay for the heater

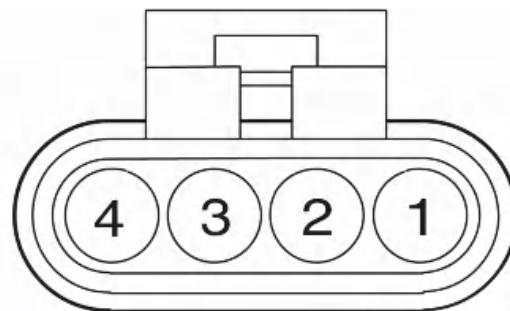

Injection load relay

- 30.** (White/Black) Battery power supply input
- 85.** (Black/Purple) Signal input (-) for coil from the MIUG4 control unit
- 86.** (Red/White) Key-on power supply input
- 87.** (Black / Green) Power supply output from contact for injection loads

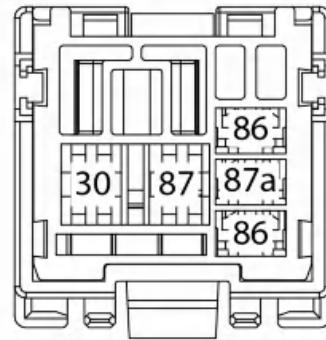
**Electric fan contactor**

- 30.** (Grey) Battery power supply input
- 85.** (Blue/Yellow) Signal input (-) for coil from the MIUG4 control unit
- 86.** (Black/Green) Power supply input from injection load relay
- 87.** (Red) Signal output (+) for electric fan activation

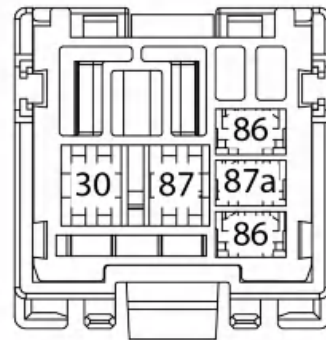
**Light relay**

- 30.** (Grey) Battery power supply input
- 85.** (Purple/White) Signal input (-) from the MIUG4 control unit
- 86.** (White) Key on power supply input
- 87.** (Grey/Red) Signal output (+) for lights selector switch

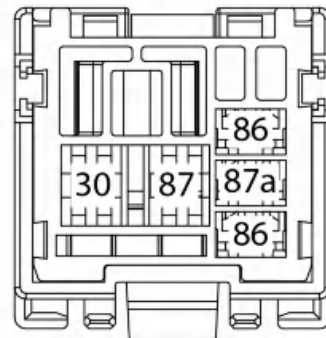
**MY 2019 VERSION**

The list, in alphabetical order, of the vehicle's electrical components is provided below:

- Immobilizer antenna
- Engine stop
- Saddle opening actuator
- Bike Finder
- Blinker
- H.V. coil
- Starter relay coil
- ABS control unit
- MIUG4 control unit
- Horn

- Ignition switch
- Turn signal switch
- Starter relay contact
- Light switch
- Electric fan
- Tail light
- OBD socket fuse
- Main fuse
- Instrument cluster
- Right turn indicator and parking light
- Left turn indicator and parking light
- Rear right turn indicator
- Rear left turn indicator
- Fuel level indicator
- Injector
- Frame ground
- Battery negative
- Pickup / Oil pressure sensor
- Fuel pump
- Fuse box
- Battery positive
- Accessories pre-installation
- OBD port
- USB port
- Headlight
- Saddle release switch
- ASR Button
- Stand button
- Horn button
- Start button
- MODE button
- RH brake light button
- LH brake light button
- Voltage regulator
- Front ABS sensor
- Rear ABS sensor
- Roll-over sensor
- Engine temperature sensor

- Lambda probe with heater
- Injection load relay
- Electric fan contactor
- Light relay

Immobilizer antenna

- 1. (Red/White) Key-on power supply input
- 2. (Black) Ground
- 3. (Orange/White) - "ENABLE" signal output for MIG4 control unit

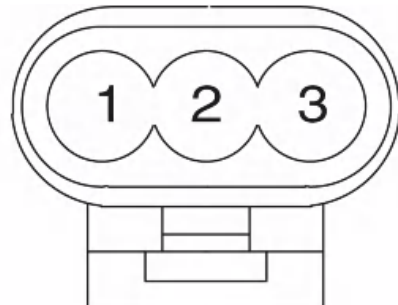

Engine stop

- A. Not connected
- B. (Grey / Green) Signal output for MIUG4 control unit
- C. (Green//Black) Ground reference from the MIUG4 control unit

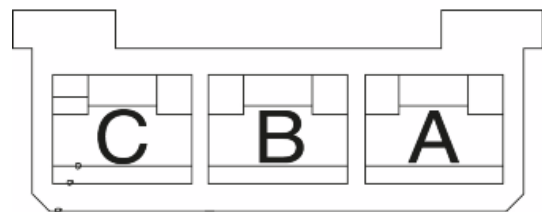

Saddle opening actuator

- 1. (Black) Ground
- 2. (Blue) Saddle release signal input

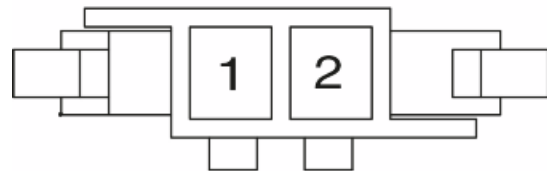

Bike Finder

- 1. (Grey) Battery power supply input (from fuse F2)
- 2. (White) Key-on power supply input (from fuse F5)
- 3. (Black) Ground
- 4. (Pink) Left hand turn indicator lights signal output
- 5. (Blue) Saddle release signal input
- 6. (White/Blue) Right hand turn indicator lights signal output

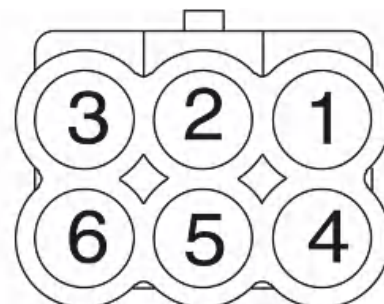

Blinker

- L.** (Blue/Black) Signal output for flashers switch
- B.** (White) Key-on power supply input (from fuse F5)

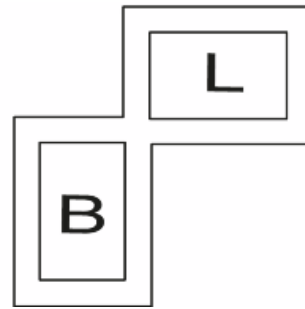
**H.V. coil**

- 1.** (Pink / Black) Signal input (-) from the MIUG4 control unit
- 2.** (Black/Green) Power supply input from injection load relay

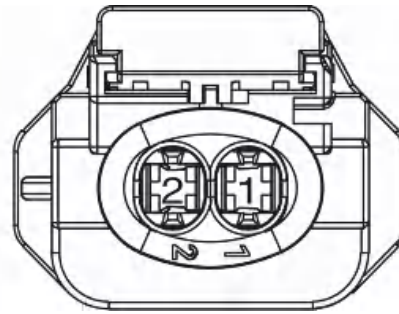
**Starter relay coil**

- (White/Black) Key-on power supply input from STOP buttons (right and/or left)

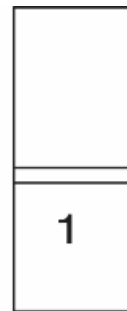
**Starter relay coil**

- (Orange / Blue) Signal input (-) from the MIUG4 control unit

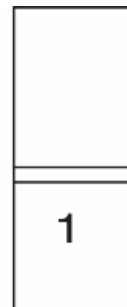
**ABS control unit**

- 1.** Not connected
- 2.** (Pink/Red) CAN H line
- 3.** (Blue/Green) - ABS indicator lamp command signal (-) output
- 4.** (Red/White) Key-on power input (from fuse F4)
- 5.** (Orange/Black) K line
- 6.** (Brown/Red) Rear wheel sensor signal input
- 7.** Not connected
- 8.** (Light blue/Red) Front wheel sensor signal input

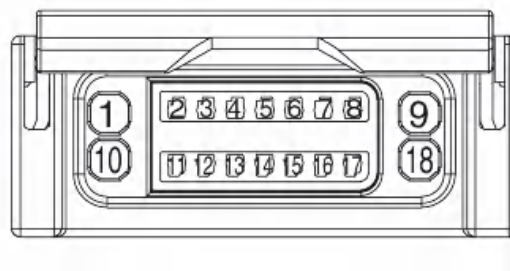

9. Not connected
10. (Black) Ground
11. (Pink/White) CAN L Line
12. Not connected
13. (Light blue) Vehicle speed signal output
14. (Black) PCC ground_2
15. (Brown/Black) Ground reference for rear wheel sensor
16. (Black) PCC ground_1
17. (Light blue/Black) Ground reference for front wheel sensor
18. (Grey/Red) Battery power supply input (from fuse F3)

MIUG4 control unit

1. (Pink/Black) H.V. coil signal output (-)
2. Not connected
3. (Blue/Brown) ASR warning light command signal output
4. (Green/Black) Signal input (-) from engine stop button
5. (Brown/Red) Signal input (+) from the start button
6. (Red/White) Key-on power input (from fuse F4)
7. (Black) Power ground
8. Not connected
9. (White/Black) Battery power input (from fuse F1)
10. (Orange/Blue) Starter relay coil command signal output (-)
11. (Light blue/Black) Lambda probe (+)
12. (White/Green) Lambda probe (-)
13. (Light blue/Green) Engine temperature sensor signal input
14. (Orange/White) "ENABLE" signal input from the immobilizer antenna
15. (Grey/Green) Sensor ground reference
16. Not connected

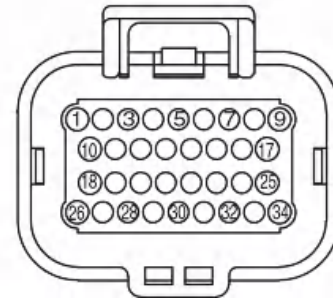

17. (Red/Green) Immobilizer warning light control signal output (-)

18. (Grey/Black) Tilting sensor signal input

19. (Brown/Red) Signal input (-) from the stand button

20. (Brown) Pickup (-)

21. (Light blue/White) Signal input (-) from the ASR button

22. (Black/Purple) Injection loads coil command signal output (-)

23. (Black) Power ground

24. (Blue/Yellow) Electric fan relay coil command signal output (-)

25. (Brown/Black) MIL warning light control signal output (-)

26. (Pink/Red) CAN H line

27. (Pink/White) CAN L Line

28. Not connected

29. (Red) Pickup (+)

30. Not connected

31. (Light blue/red) Ground reference for lambda probe heater

32. Not connected

33. (Purple/White) Lights relay coil command signal output (-)

34. (Red/Yellow) Injector command signal output (-)

Horn

- (Yellow/Pink) Signal (+) input from horn button

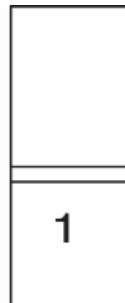

Horn

- (Black) Ground



Ignition switch

- 1. (Grey) Battery power supply input (from fuse F2)
- 2. Not connected
- 3. (Blue / Black) Key on power supply output for the saddle release button
- 4. (Orange) Key-on power supply output for fuses F4, F5, F6
- 5. (Red/Black) - Battery power supply input

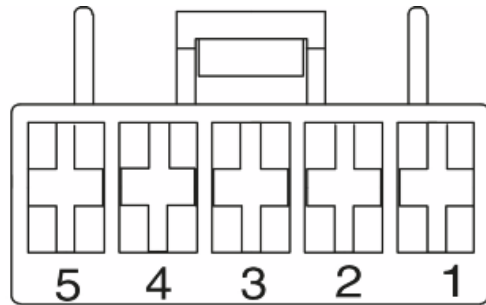

Turn signal switch

- A. (Pink) Signal output from left hand flashers
- B. (Blue/Black) - Signal input from Blinker
- C. (White/Blue) Signal output from right hand flashers

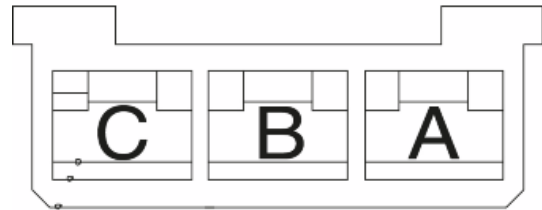

Starter relay contact

- (Red) Battery power supply input

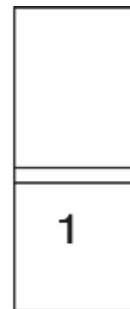

Light switch

- A. (Grey / Red) Power input from the lights relay contact
- B. (Brown) Low beam lights activation signal output
- C. (Purple) High beam lights activation signal output

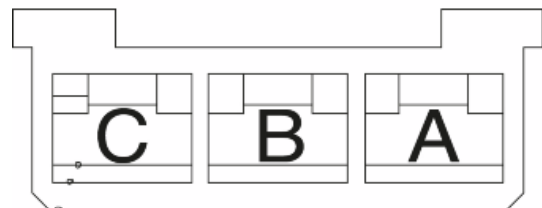

Electric fan

- 1. (Black) Ground
- 2. (Red) Power supply input from electric fan relay contact

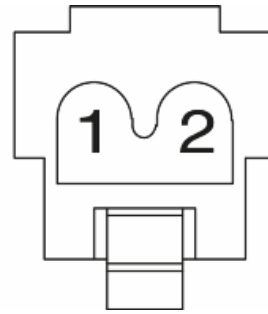
**Tail light**

- 1. (Yellow/Black) Parking lights key-on power supply input (from fuse F6)
- 2. (Black) Ground
- 3. (White/Black) Brake light activation signal (+) input

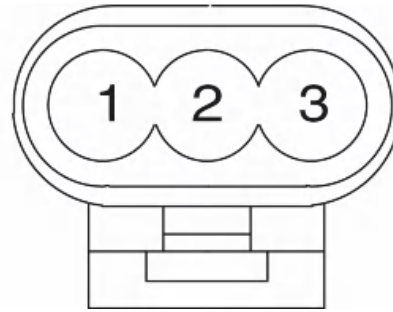
**OBD socket fuse**

- 1. (Red / Yellow) Power supply output for OBD socket
- 2. (Grey) Battery power supply input (from fuse F2)

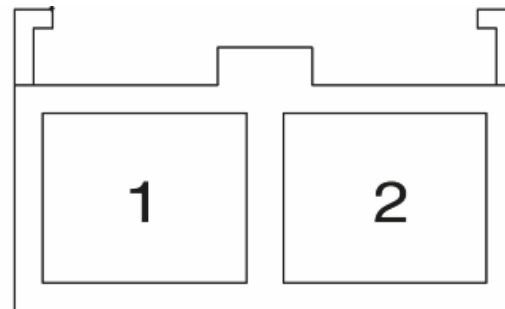
**Main fuse**

- 1. (Red) Battery power input
- 2. (Red/Black) Battery power supply output

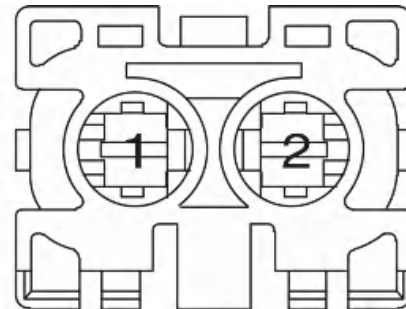
**Instrument cluster**

- 1. (Pink / Green) Engine oil indicator light command signal input (-)
- 2. (Green) Signal input (-) from the MODE button
- 3. (Pink) - Left hand turn signal indicator command signal input
- 4. (White/Blue) - Right hand turn signal indicator command signal input
- 5. (Purple) - High beam indicator light command signal input (+)

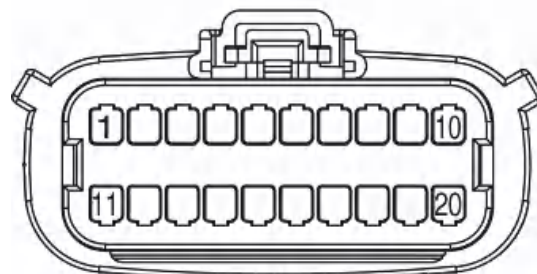

- 6. (Blue/Green) ABS indicator light command signal input (-)
- 7. (Blue/Brown) ASR indicator light command signal input
- 8. Not connected
- 9. Not connected
- 10. Not connected
- 11. Not connected
- 12. (White/Green) Fuel level signal input
- 13. Not connected
- 14. (Light blue) Vehicle speed signal input
- 15. Not connected
- 16. (Brown/Black)
- 17. (Black) Ground
- 18. (Red/Green) Immobilizer warning light control signal input (-)
- 19. (Yellow/Black) Key-on power supply input (from fuse F6)
- 20. (Grey) Battery power supply input (from fuse F2)

Right turn indicator and parking light

- 1. (White/Blue) Turn indicator activation signal input (+)
- 2. (Yellow/Black) Parking light activation signal input (+)
- 3. (Black) Ground

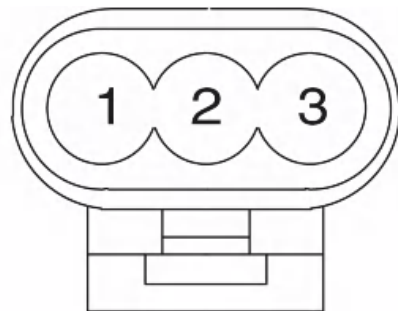

Left turn indicator and parking light

- 1. (Pink) Turn indicator light activation signal input (+)
- 2. (Yellow/Black) Parking light activation signal input (+)
- 3. (Black) Ground

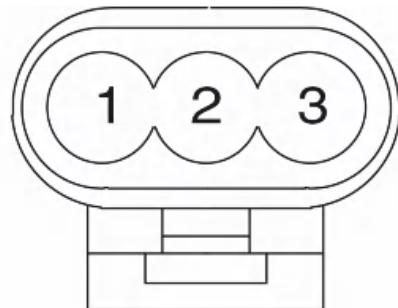

Rear right turn indicator

- 1. (Black) Ground
- 2. (White/Blue) Turn indicator activation signal input (+)

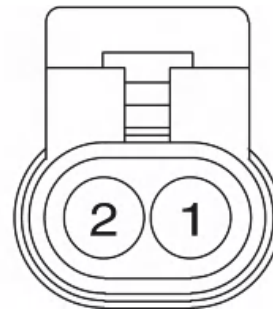
**Rear left turn indicator**

- 1. (Black) Ground
- 2. (Pink) Turn indicator light activation signal input (+)

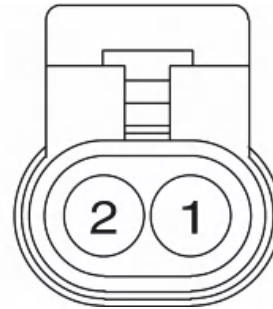
**Fuel level indicator**

- 1. (White/Green) Fuel level signal output
- 2. (Black) Ground
- 3. Not connected

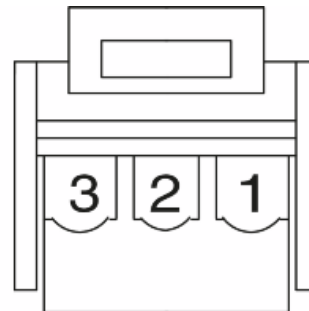
**Injector**

- 1. (Black/Green) Power supply input from injection load relay
- 2. (Red/Yellow) Signal input (-) from the MIUG4 control unit

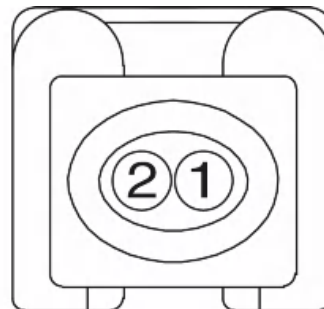
**Frame ground**

- (Black) Direct connection with the battery negative
- (Black) Power ground for vehicle electric devices



Battery negative

- (Black) Direct connection with the chassis ground point
- (Black) Direct connection with the voltage regulator

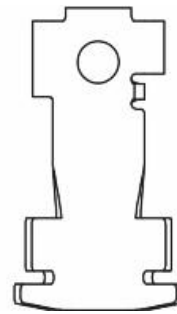

Pickup / Oil pressure sensor

- 1. (Red) Power supply from the MIUG4 control unit
- 2. (Brown) Ground reference from the MIUG4 control unit
- 3. (Pink/Green) Engine oil warning light activation command signal output (-)

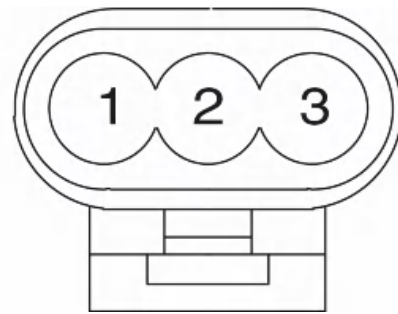

Fuel pump

- 1. (Black) Ground
- 2. (Black/Green) Power supply input from injection load relay

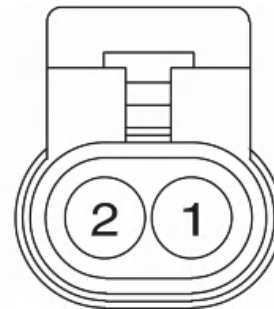

Fuse box

- 1. (White/Black) Battery power output from fuse F1
- 2. (Grey) Battery power supply output from fuse F2
- 3. (Grey/Red) Battery power supply output from fuse F3
- 4. (Red/White) Key-on power supply output from fuse F4
- 5. (White) Key-on power supply output from fuse F5
- 6. (Yellow/Black) Key-on power supply output from fuse F6
- 7. (Red/Black) Battery power supply input for fuse F1
- 8. (Red/Black) Battery power supply input for fuse F2

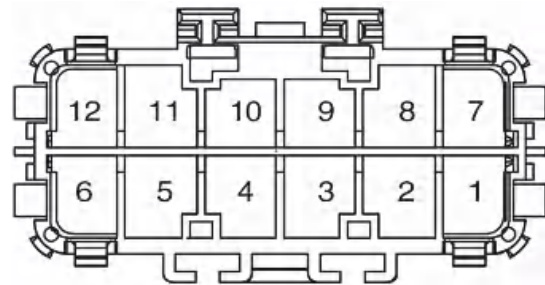

9. (Red/Black) Battery power supply input for fuse F3

10. (Orange) Key-on power supply input for fuse F4

11. (Orange) Key-on power supply input for fuse F5

12. (Orange) Key-on power supply input for fuse F6

Battery positive

- (Red) Direct connection with the 30A main fuse
- (Red) Direct connection with starter motor relay contact

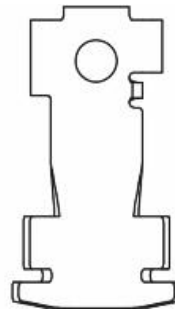

Accessories pre-installation

1. (Black) Ground
2. (White/Green) Fuel level signal
3. (Pink/Red) CAN H line
4. (Pink/White) CAN L Line
5. (Orange/Black) K line
6. Not connected
7. (Grey) Battery power supply input from fuse F2
8. (White) Key-on power supply input from fuse F5
9. Not connected
10. (Blue) Saddle release signal
11. (Pink) Left hand turn indicator signal
12. (White/Blue) Right hand turn indicator signal
13. (Purple) High-beam light signal
14. (Light blue) Vehicle speed signal

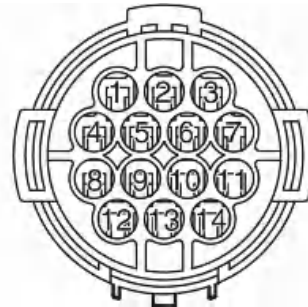

OBD port

1. (Yellow/Black) Key-on power supply input from fuse F6
2. (Pink/Red) CAN H line
3. (Black) Ground
4. (Red/Yellow) Battery power supply input from the specific protection fuse 5A

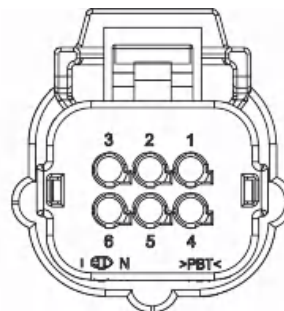

5. (Pink/White) CAN L Line

6. (Orange/Black) K line

USB port

)1. (White) Key-on power supply input from fuse

F5

2. (Black) Ground

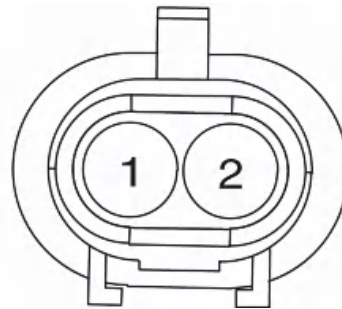

Headlight

)1. (Brown) Low beam light activation signal input

(+)

2. (Purple) High beam light signal input (+)

3. (Black) Ground

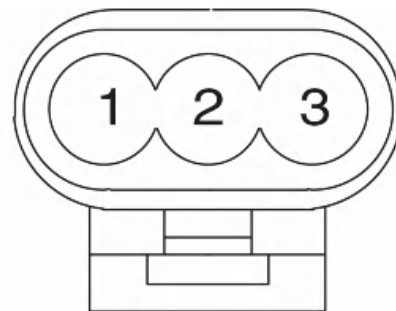

Saddle release switch

)1. (Blue / Black) Key on power supply input from the ignition switch

2. (Blue) Saddle release signal output (+)

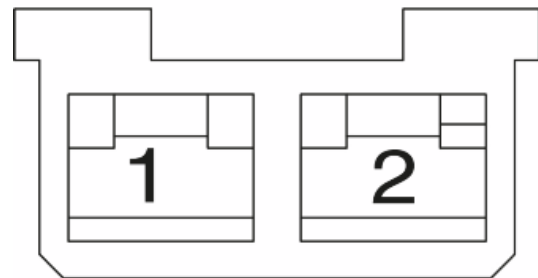

ASR Button

A. (Grey/Green) Ground reference from the MIUG4 control unit

B. Not connected

C. (Light blue/White) Signal output (-) for the MIUG4 control unit

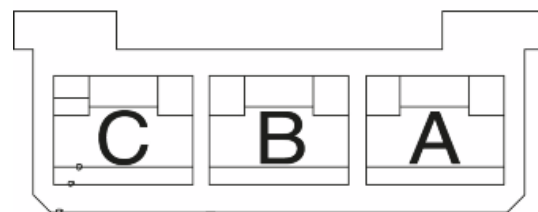

Stand button

)1. (Brown/Red) Signal output (-) for the MIUG4 control unit

2. (Grey/Green) Ground reference from the MIUG4 control unit

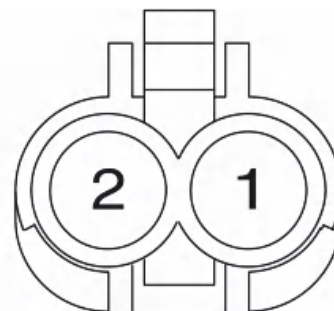

Horn button

- 1. (Yellow/Red) Signal output (+) for horn activation
- 2. (White) Key-on power supply input from fuse F5
- 3. Not connected

**Start button**

- 1. (Brown/Red) - Key-on power supply input from fuse F4
- 2. (Red/White) Signal output (+) for the MIUG4 control unit
- 3. Not connected

**MODE button**

- 1. (Green) Signal output (-) for the instrument cluster
- 2. (Black) Ground

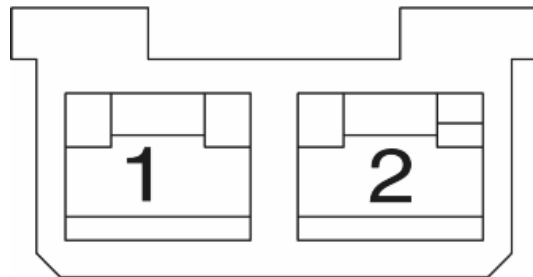
**RH brake light button**

- (White) Key-on power supply input from fuse F5

**RH brake light button**

- (White/Black) Signal output for brake light activation and starter relay coil power supply



LH brake light button

(White) Key-on power supply input from fuse F5



LH brake light button

- (White/Black) Signal output for brake light activation and starter relay coil power supply



Voltage regulator

- 1. (Red/Black) Battery power supply input from the 30A main fuse
- 2. (Black) Direct ground from the battery negative

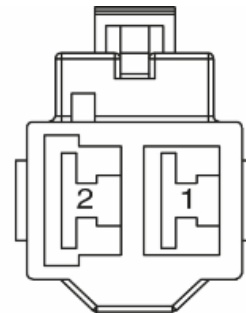

Front ABS sensor

- 1. (Light blue/Black) Ground reference from the ABS control unit
- 2. (Light blue/Red) - Signal output for ABS control unit

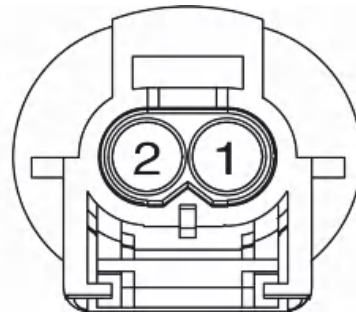

Rear ABS sensor

- 1. (Brown/Black) Ground reference from the ABS control unit
- 2. (Brown/Red) Signal output for the ABS control unit

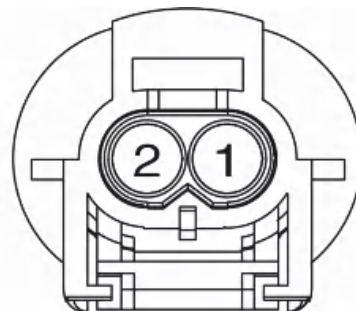

Roll-over sensor

- 1. Not connected
- 2. (Grey/Green) - Ground reference from the MIUG4 control unit
- 3. (Red/White) Key-on power supply input from fuse F4
- 4. (Grey / Black) Signal output for the MIUG4 control unit

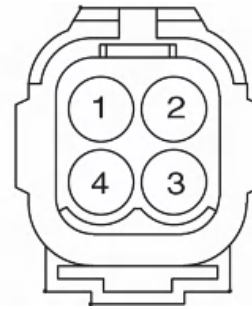
**Engine temperature sensor**

- 1. (Grey/Green) - Ground reference from the MIUG4 control unit
- 2. Not connected
- 3. (Light blue / Green) Signal output for the MIUG4 control unit
- 4. Not connected

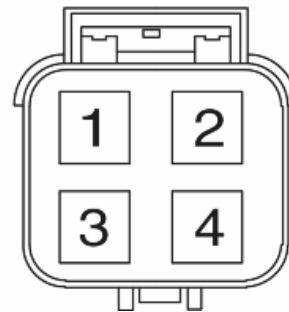
**Lambda probe with heater**

- 1. (Light blue/Black) Power supply from the MIUG4 control unit for the lambda probe
- 2. (White/Green) Ground reference from the MIUG4 control unit for the lambda probe
- 3. (Light blue/Red) Ground reference from the MIUG4 control unit for the heater
- 4. (Black/Green) Power supply input from the injection load relay for the heater

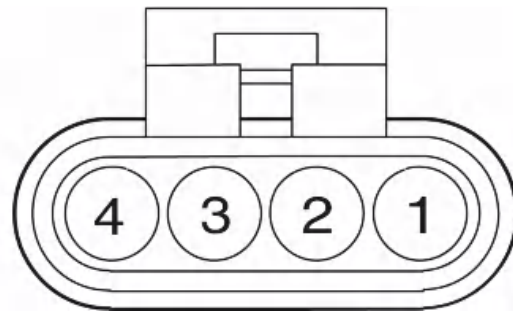
**Injection load relay**

- 30. (White/Black) Battery power supply input from fuse F1
- 85. (Black/Purple) Signal input (-) for coil from the MIUG4 control unit
- 86. (Pink/White) Key-on power supply input for coil from fuse F4
- 87. (Black / Green) Power supply output from contact for injection loads

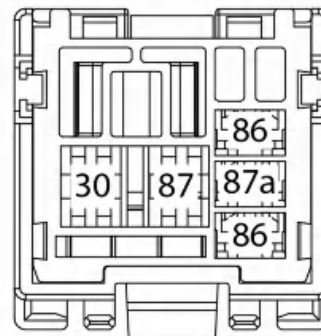

Electric fan contactor

- 30.** (Grey) Battery power supply input from fuse F2
- 85.** (Blue/Yellow) Signal input (-) for coil from the MIUG4 control unit
- 86.** (Black/Green) Power supply input from injection load relay
- 87.** (Red) Signal output (+) for electric fan activation

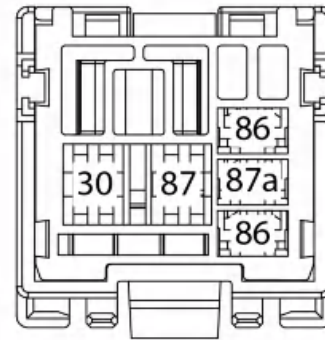
**Light relay**

- 30.** (Grey) Battery power supply input from fuse F2
- 85.** (Purple/White) Signal input (-) from the MIUG4 control unit
- 86.** (White) Key-on power supply input from fuse F5
- 87.** (Grey/Red) Signal output (+) for lights selector switch

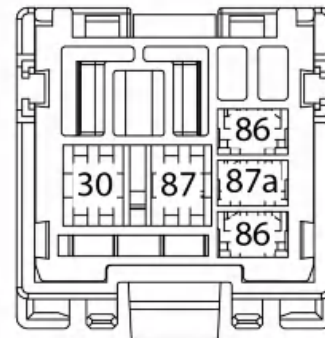
**Remote seat opening****Battery replacement**

The remote control is powered by internal batteries that get discharged after extended use; If the LED turns on when the button is pressed, the remote control is working properly.

You may need to replace the batteries if the remote control fails or if its range of operation is reduced. To separate the two halves of the remote control, insert the blade of a plain slot screwdriver at one point on the edge and slide it all around.

Once the remote control is open, remove the two batteries from the contact terminal. Install the two new CR2016 batteries with the positive pole facing the contact terminal. Reassemble the remote control by pressing the two clip-on halves gently with your fingers.

To open the saddle itself without using the remote control, it is possible to proceed as described in section «Saddle opening».

Programming

To program the new radio commands, do the following:

1. disconnect the battery of the vehicle;
2. reconnect the battery of the vehicle;
3. within 5 seconds of reconnecting the battery, simultaneously press buttons "1" and "3" on the remote control twice. the «Bike Finder» device will confirm the process with an optical signal by the quick flashing of the turn indicator;
4. the programming of the new radio command generates the end of the procedure and the system is ready for use.

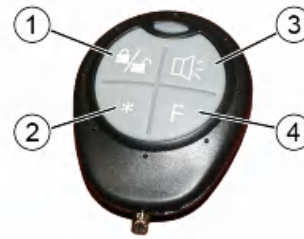

If it is necessary to erase a radio command from the memory of the device, it will be necessary to repeat the programming 4 times even with the same remote control, in order to recover the 4 provided memories.

CAUTION



TO STORE THE OTHER REMOTE CONTROLS TO MEMORY (4 MAXIMUM) YOU NEED TO REPEAT THE WHOLE PROCEDURE AGAIN. FAILURE TO CARRY OUT THESE OPERATIONS WITHIN THE INDICATED TIMES WILL RESULT IN THE REMOTE-CONTROL UNIT KEY PROGRAMMING PROCEDURE BEING ABANDONED AUTOMATICALLY. STORING A FIFTH REMOTE CONTROL MAY LEAD TO CANCELLATION OF THE FIRST ONE.

WARNING



DO NOT KEEP THE REMOTE CONTROL IN PLACES WITH TEMPERATURES EXCEEDING 60° C THE BATTERY WILL RUN DOWN TOO QUICKLY.

CAUTION



TO AVOID BATTERY DISCHARGE, THE SADDLE OPENING REMOTE CONTROL RADIO RECEIVER DEACTIVATES 3 MINUTES AFTER THE LAST RECEIPT. TO RESTORE FUNCTIONS SIMPLY PRESS THE ACTIVATION BUTTON ON THE REMOTE CONTROL FOR ABOUT 3 SECONDS, AS DESCRIBED ABOVE.

INDEX OF TOPICS

ENGINE FROM VEHICLE

ENG VE

This section describes the operations to carry out when removing the engine from the vehicle.

FRAME ASSEMBLY

Name	Torque in Nm
Swinging arm pin - engine	64 - 72
swinging arm bolt - body shell	76 to 83
Engine and vehicle side swinging arm junction bolt	33 - 41
Bolt of the Silent block support plate	42 to 52
Central stand bolt	32 - 40
Side stand fixing bolt	35 - 40

REAR SUSPENSION

Name	Torque in Nm
Retainer for left shock absorber to crankcase support plate	20 - 25
Shock absorber lower fitting	40 - 45
Shock absorber upper fitting	20 - 25
Rear wheel axle	104 ÷ 126
Screw fixing wheel to hub	20 - 25
Screws for silencer - shock absorber support arm on engine	20 - 25 (The two screws must be tightened after having done so with the rear wheel axle nut at the specified torque. Safety fasteners: see «Pre-delivery Operations»)
Engine- and vehicle-side swinging arm junction bolt	40 - 45

SILENCER

Name	Torque in Nm
Silencer heat guard fixing screw	4 - 5
Screw used to fasten silencer to supporting arm	20 - 25
Lambda probe tightening on exhaust manifold	40 - 50
Manifold/silencer joint tightening torque	12 - 13
Manifold - silencer diaphragm tightening clamp	16 - 18

Exhaust assy. Removal

- Remove the left and right fairing and spoiler terminals.

- Remove the Lambda probe from its support and disconnect it.



Remove the lambda probe cable retainer clamp from the coolant pipe shown in the photo



- Undo the two exhaust manifold fixings on the head. To unscrew the nuts that fix the silencer flange to the head properly, use a jointed wrench that allows, according to the travel direction, to get also at the right nut. That is difficult to do with a traditional straight wrench.

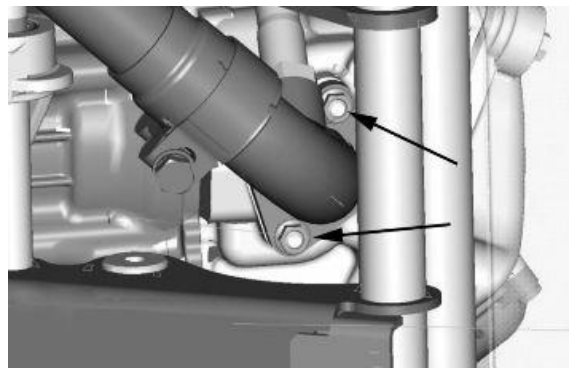

- Undo the three screws that fix the muffler to the support arm.
- Remove the complete silencer.



- Remove the lambda probe from the manifold.



CAUTION
WARNING



SHOULD IT BE NECESSARY TO REMOVE ONLY THE SILENCER TIP, ALWAYS REPLACE THE GRAPHITE GASKET BETWEEN THE PRIMARY PIPE AND SILENCER.

Removal of the engine from the vehicle

CAUTION



SUPPORT THE VEHICLE ADEQUATELY.

- Disconnect the battery.
- Remove the helmet compartment.
- Remove the side fairings and the spoiler terminals.
- Remove the rear brake calliper.
- Remove the air cleaner from the housing by unscrewing the three screws indicated in the photograph.

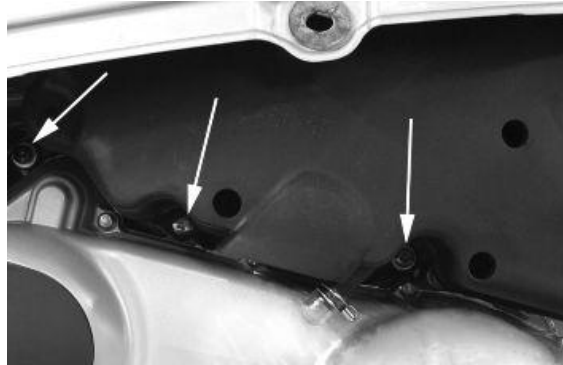

CAUTION



THIS OPERATION MUST BE CARRIED OUT WHEN THE ENGINE IS COLD.

- Remove the clamp from the blow-by pipe and take the pipe out; remove the retainer clamp.
- Remove the clamp indicated in the photograph and disconnect the sleeve connecting it to the throttle body.

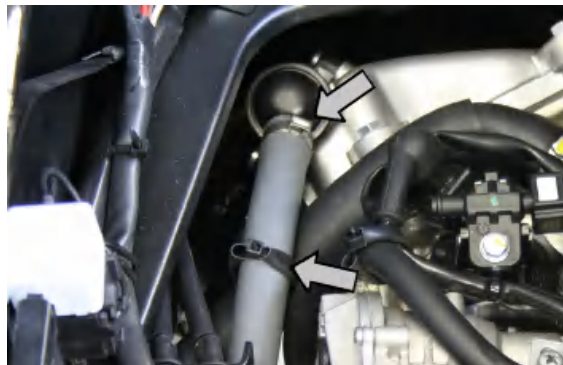

- Get a + 2.5 l container to collect the coolant.

- Remove the coolant inlet pipe to the motor as indicated in the photograph.

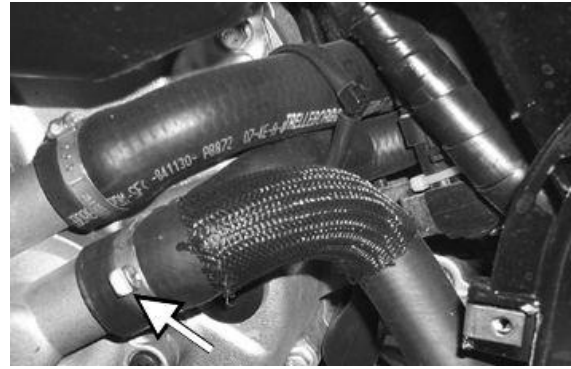

- Disconnect the fuel pipe from the injector and remove the screw locking the retainer clamp.
- Disconnect the injector wiring and the throttle body control unit wiring.

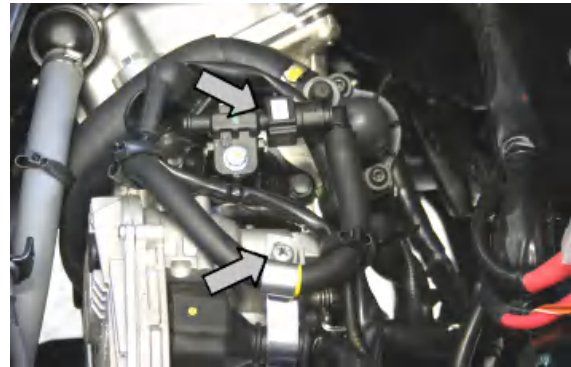

- Disconnect the cable harnesses from the two clamps indicated.

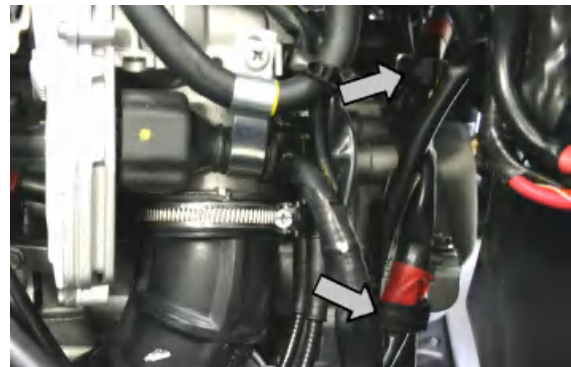

- Remove the coolant outlet pipe from the engine as indicated.

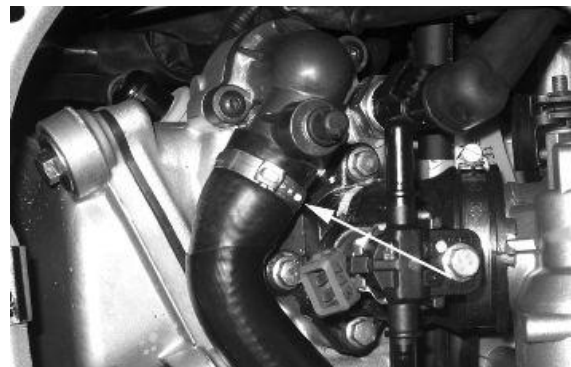

- Remove the spark plug cap.
- Remove the coolant temperature sensor connector indicated in the picture.

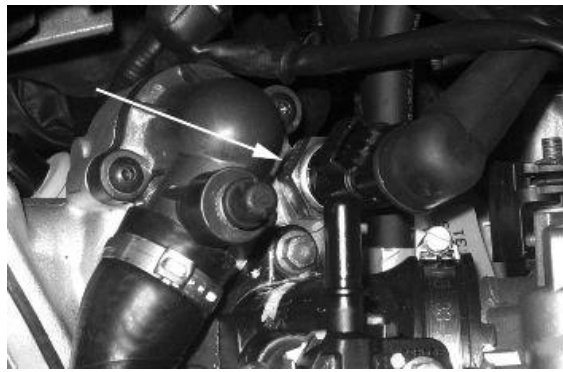

- Remove the throttle control cables from the throttle body by undoing the nuts indicated in the photograph.



- Loosen the clamp indicated in the photograph and remove the throttle body.

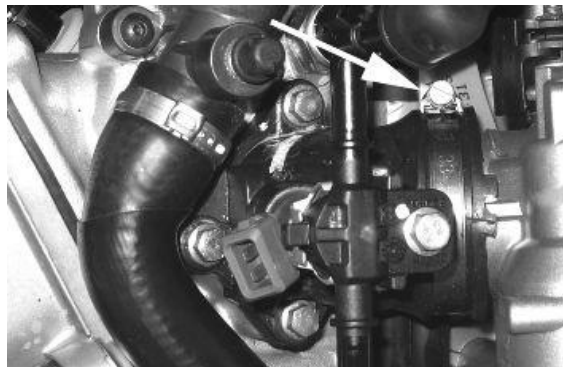

- Remove the clamp retaining the starter motor from the sleeve.



- Remove the positive and negative wiring from the starter motor as shown in the picture.

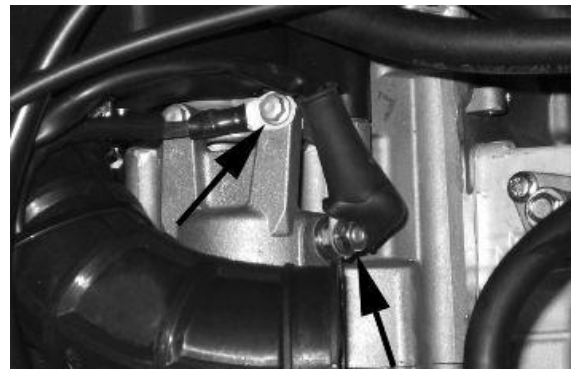

- Disconnect the connectors from the flywheel wiring as shown in the photo.
- Release the cables from the retainer clamps.

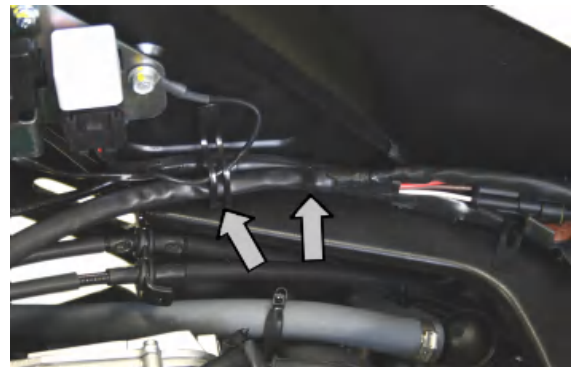

- Remove the four retainers of the rear brake pipes from the crankcase.
- Remove the rear shock absorbers.



- Remove the engine-swinging arm fixing pin by undoing the nut and operating on the head of the pin as shown in the photograph.
- The engine is now free.

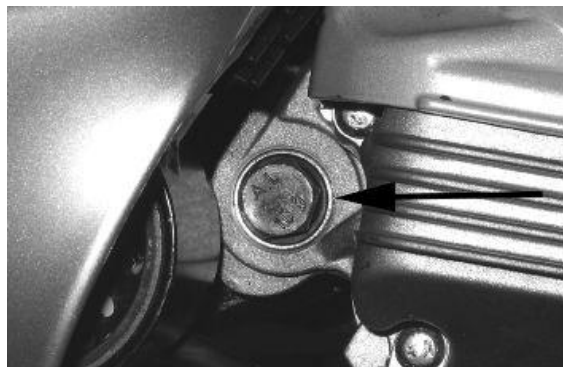
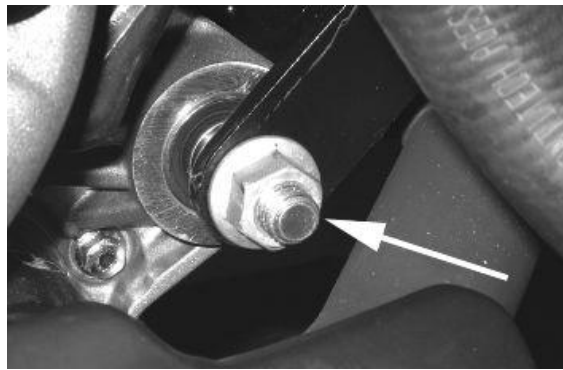

Upon refitting the engine to the vehicle, carry out the removal operations but in reverse order, and respect the tightening torques shown in the «Specifications» Chapter.

- Check that there is a small clearance when the valve is in abutment against the set screw.
- Check the engine oil level and if necessary, top it up with the recommended type.
- Fill and bleed the cooling circuit.
- Check accelerator and electric devices for correct functioning.
- Pay particular attention to the sleeve, be careful to position the throttle body reference marks as indicated in the photograph.



CAUTION

PAY PARTICULAR ATTENTION TO POSITIONING THE THROTTLE CONTROL TRANSMISSION PROPERLY.

INDEX OF TOPICS

ENGINE

ENG

This section describes the operations to be carried out on the engine and the tools to be used.

SILENCER

Name	Torque in Nm
Silencer heat guard fixing screw	4 - 5
Screw used to fasten silencer to supporting arm	20 - 25
Lambda probe tightening on exhaust manifold	40 - 50
Manifold/silencer joint tightening torque	12 - 13
Manifold - silencer diaphragm tightening clamp	16 - 18

LUBRICATION

Name	Torque in Nm
Hub oil drainage plug	15 to 17
Oil filter on crankcase fitting	27 - 33
Engine oil drainage plug/ mesh filter	24 to 30
Oil filter	4 - 6
Oil pump cover screws	7 - 9
Screws fixing oil pump to the crankcase	5 to 6
Oil pump command sprocket screw	10 - 14
Oil pump cover plate screws	4 - 6
Oil sump screws	10 - 14
Minimum oil pressure sensor	12 - 14

CYLINDER HEAD

Name	Torque in Nm
Spark plug	12 - 14
Cylinder head cover screws	6 - 7
Nuts fixing head to cylinder	$7\pm 1 + 10\pm 1 + 270^\circ$
Head fixing side screws	11 - 12
Starter ground screw	7 to 8.5
Tappet adjustment check nut	6 - 8
Inlet manifold screws	11 to 13
Timing chain tensioner slider screw	10 - 14
Starter counterweight support screw	11 to 15
Timing chain tensioner support screw	11 to 13
Timing chain tensioner central screw	5 to 6
Camshaft retention plate screw	4 - 6

TRANSMISSION

Name	Torque in Nm
Belt support roller screw	11 to 13
Clutch unit nut on driven pulley	45 - 50
Driver pulley nut	75 - 83
Transmission cover screws	11 - 13 Nm
Driven pulley shaft nut	54 - 60
Rear hub cover screws	24 to 27

FLYWHEEL

Name	Torque in Nm
Flywheel cover screw	11 to 13
Stator assembly screws	3 - 4 (Apply LOCTITE medium type 242 threadlock)
Flywheel nut	94 - 102
Pick-up fixing screws	3 - 4
Screw fixing freewheel to flywheel	13 - 15

CRANKSHAFT AND CASE

Name	Torque in Nm
Internal engine crankcase bulkhead (transmission-side half shaft) screws	4 - 6
Engine-crankcase coupling screws	11 to 13
Starter screws	11 to 13
Crankcase timing cover screws	3.5 - 4.5 (Apply LOCTITE medium type 242 threadlock)

Automatic transmission

Transmission cover

To remove the transmission cover, proceed as follows:

- Block clutch housing rotation using the appropriate tool.

Specific tooling

020423Y Driven pulley lock wrench



- Unscrew the fixing nut.

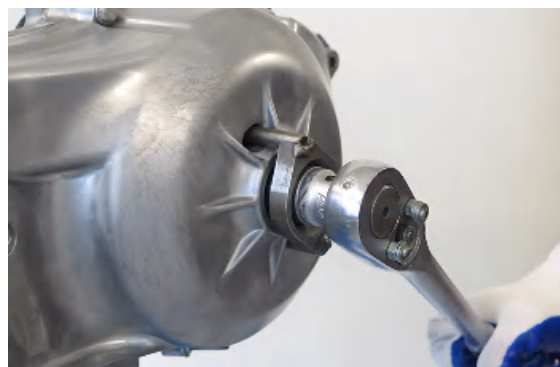

- Remove the nut and the washer.



- Unscrew and remove the transmission cover's fixing screws.



- Remove the transmission cover.

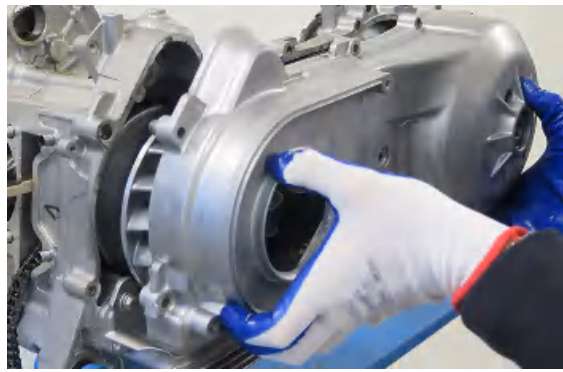

Removing the driven pulley shaft bearing

To remove the driven pulley shaft support bearing, proceed as follows:

- Remove the Seeger ring inside the transmission cover.



- Remove the bearing using the specific tool.

Specific tooling

020376Y Adaptor handle

020375Y 28 x 30 mm adaptor

020412Y 15-mm guide



Refitting the driven pulley shaft bearing

- Heat the transmission cover from the inside.
- Insert a new bearing using the specific tool.

Specific tooling

020376Y Adaptor handle

020375Y 28 x 30 mm adaptor

020412Y 15-mm guide



- Fit the Seeger ring.



Baffle roller

Plastic roller

- Check that the roller does not show signs of wear and that it turns freely.
- Remove the special clamping screws as indicated in the picture

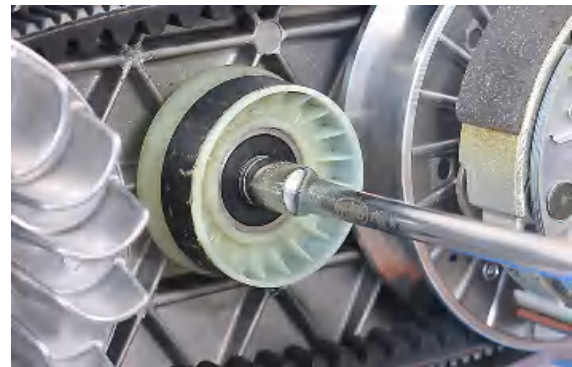

- Check the outer diameter of the roller does not have defects that could jeopardise belt functioning
- For refitting, place the roller with the belt containment edge on the engine crankcase side
- Tighten the wrench to the prescribed torque.



Locking torques (N*m)

Anti-flapping roller 12 - 16

Removing the driven pulley

- Remove the clutch housing and the driven pulley assembly.

N.B.

THE UNIT CAN ALSO BE REMOVED WITH THE DRIVING PULLEY MOUNTED.



Inspecting the clutch drum

- Make sure that the clutch housing is not worn or damaged.
- Measure the clutch housing inside diameter.

Characteristic

Clutch housing max. value

Max. value: \varnothing 134.5 mm

clutch housing standard value

Standard value: \varnothing 134 - 134.2 mm



Checking the bell working surface eccentricity

- Install the bell on a driven pulley shaft using 2 bearings (inside diameter: 15 and 17 mm).
- Lock with the original spacer and nut.
- Place the bell/shaft unit on the support to check the crankshaft alignment.



- Using a dial gauge and the magnetic base, measure the bell eccentricity.
- Repeat the measurement at 3 positions (Central, internal, external).
- In case of faults, replace the bell.



Specific tooling

020074Y Support base for checking crankshaft alignment

020335Y Magnetic mounting for dial gauge

Characteristic

clutch housing check: Limit eccentricity.

Admissible limit eccentricity: 0.15 mm

Removing the clutch

To remove the driven pulley unit, proceed as follows:

- Fit the specific driven pulley spring compressor tool, fixing it firmly in a vice.



Specific tooling

020444Y Tool for installing/removing clutch on/from driven pulley

- Insert the long pins in the "F" position, screwed from the external side of the tool.

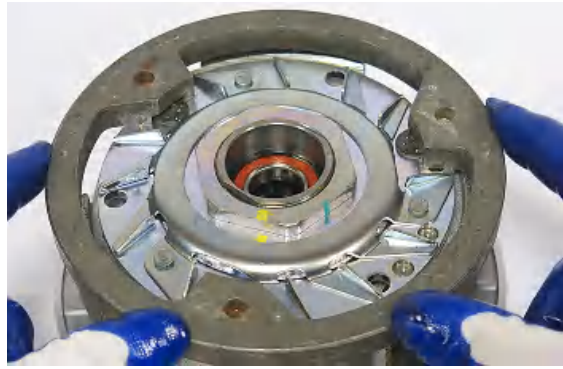

- Fit the adapter ring on the clutch.

Specific tooling**020444Y008 adapter ring**

- Fit the driven pulley assembly on the tool together with the adapter ring.



- Tightening the screw mechanism of the tool, compress the return spring.

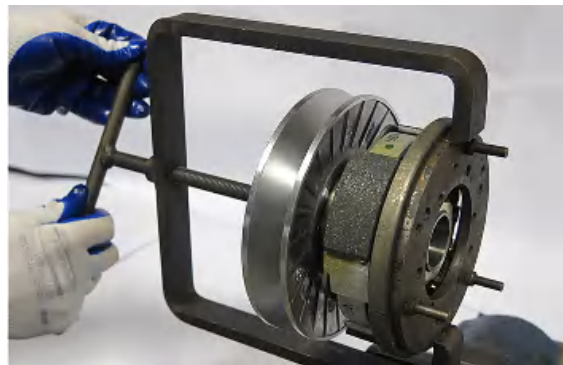

- Using the specific 46x55 wrench, unscrew the clutch fixing hexagonal fixing ring.

Specific tooling**020444Y009 wrench 46 x 55**

- Remove the hexagonal ring nut.
- Loosen the screw mechanism of the tool and separate the driven pulley components



Inspecting the clutch

- Check the thickness of the clutch mass friction material.
- The masses must exhibit no traces of lubricants; in that case, check the driven pulley unit seals.

N.B.

UPON RUNNING-IN, THE MASSES MUST EXHIBIT A CENTRAL FACING SURFACE AND MUST NOT BE DIFFERENT FROM ONE ANOTHER. VARIOUS CONDITIONS CAN CAUSE THE CLUTCH TO TEAR.

CAUTION

DO NOT USE TOOLS TO OPEN THE MASSES TO AVOID VARIATION IN THE RETURN SPRING LOAD.



Characteristic

Check minimum thickness

1 mm

Pin retaining collar

- Simultaneously turn and pull the collar manually to remove it.

N.B.

USE TWO SCREWDRIVERS IF YOU HAVE ANY DIFFICULTY.

N.B.

BE CAREFUL NOT TO PUSH THE SCREWDRIVERS IN TOO FAR TO AVOID DAMAGE THAT COULD COMPROMISE THE O-RING SEAL.



- Remove the 4 torque server pins and pull the pulley halves apart.



Removing the driven half-pulley bearing

- Check there are no signs of wear and/or noisiness; - Replace with a new one if there are.
- Remove the retainer ring using two flat blade screwdrivers.
- Support the pulley bushing adequately from the threaded side using a wooden surface.
- Using a hammer and pin, knock the ball bearing out as shown in the figure.



- Support the pulley properly using the bell as shown in the figure.

Specific tooling

001467Y035 Bearing housing, external \varnothing 47 mm



- Remove the roller bearing using the modular punch.

Specific tooling

020376Y Adaptor handle

020456Y \varnothing 24 mm adaptor

020363Y 20-mm guide

Inspecting the driven fixed half-pulley

- Measure the outside diameter of the pulley bushing.
- Check the contact surface with the belt to make sure there are no flaws.
- Check the riveted joints are functional.
- Check the evenness of the belt contact surface.

Characteristic

Half-pulley minimum diameter

Minimum admissible diameter: \varnothing 40.96 mm

Half-pulley standard diameter

Standard diameter: \varnothing 40.985 mm

Wear limit

0.3 mm



Inspecting the driven sliding half-pulley

- Remove the two seal rings and the two O-rings
- Measure the movable half-pulley bushing inside diameter.
- Check the contact surface with the belt to make sure there are no flaws.
- Check the riveted joints are functional.
- Check the evenness of the belt contact surface.

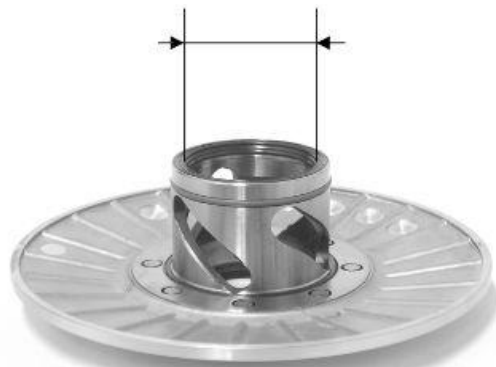

MOVABLE DRIVEN HALF-PULLEY DIMENSIONS

Specification	Desc./Quantity
Wear limit	0.3 mm
standard diameter	Ø 41.000 - 41.035 mm
maximum allowable diameter	Ø 41.08 mm

Refitting the driven half-pulley bearing

- Support the pulley bushing adequately from the threaded side using a wooden surface.
- Fit a new roller bearing as shown in the figure.
- For the fitting of the new ball bearing, follow the example in the figure using a modular punch.

Fit the retainer ring

WARNING

N.B.

FIT THE BALL BEARING WITH THE VISIBLE SHIELDING

Specific tooling

020376Y Adaptor handle

020375Y 28 x 30 mm adaptor

020424Y Driven pulley roller casing fitting punch

**Refitting the driven pulley**

- Insert the new oil seals and O-rings on the movable half-pulley.
- Lightly grease the O-rings «A» shown in the figure.
- Fit the half-pulley over the bushing using the specific tool.
- Check that the pins are not worn and proceed to refitting them in their slots.
- Refit the torque server closure collar.
- Using a curved-spout grease gun, lubricate the driven pulley unit with approximately 6 grams of

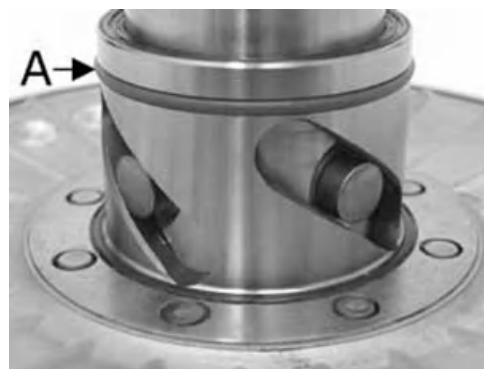

grease. Apply grease through one of the holes in the bushing until it comes out through the hole on the opposite side. This operation is necessary to avoid the presence of grease beyond the O-rings.

N.B.

THE TORQUE SERVER CAN BE GREASED WHETHER WITH BEARINGS FITTED OR WHEN THEY ARE BEING REPLACED; UNDERTAKING THE OPERATION WHEN THE BEARINGS ARE BEING SERVICED MIGHT BE EASIER.

Specific tooling

020263Y Driven pulley assembly sheath

Recommended products

Molybdenum disulphide grease Lithium grease with molybdenum disulphide

Grey black grease.



Inspecting the clutch spring

- Measure the length of the spring when it is relaxed.

Characteristic

Standard length

123 mm

Acceptable limit after use:

118 mm

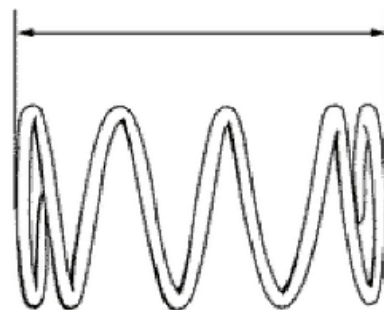

Refitting the clutch

To fit the clutch unit to the driven pulley, proceed as follows:

- Place the specific tool in the vice with the control screw on the vertical axis.

Specific tooling

020444Y Tool for installing/removing clutch on/from driven pulley



- Prepare the tool, with the long pins inserted in the "F" position, screwed from the external side.



- Put the adapter ring on the tool.

Specific tooling

020444Y008 adapter ring



- Insert the clutch on the adapter ring.



- Lubricate the end of the spring that abuts against the torque server closing collar.
- Insert the spring with its plastic holder in contact with the clutch.



- Insert the drive belt into the pulley unit according to their direction of rotation.



- Insert the pulley unit with the belt into the tool.



- Make sure that the clutch is fully inserted in the adapter ring.
- Slightly pre-load the spring.



- Place the tool in the clamp with the control screw on the horizontal axis.
- Fully pre-load the spring.
- Insert the hexagonal nut and tighten it to the prescribed torque using the specific 46x55 wrench.

N.B.

FOR DESIGN REASONS, THE NUT IS SLIGHTLY ASYMMETRIC; THE FLATTEST SURFACE SHOULD BE MOUNTED CONTACTING THE CLUTCH.

N.B.

DURING THE SPRING PRE-LOADING PHASE, BE CAREFUL NOT TO DAMAGE THE PLASTIC SPRING STOP AND THE BUSHING THREADING.



Specific tooling

020444Y009 wrench 46 x 55

Locking torques (N*m)

Centrifugal clutch - Driven pulley 48.0 ± 2.0 Nm

- Pre-load the clutch return spring with a traction/ rotation combined action and place the belt in the smaller diameter rolling position.
- Remove the driven pulley /belt unit from the tool.

**Refitting the driven pulley**

- Refit the clutch bell.

**Drive-belt**

- Check that the drive belt is not damaged.
- Check belt for correct width.

Characteristic**Drive belt - minimum width**

21,0 mm

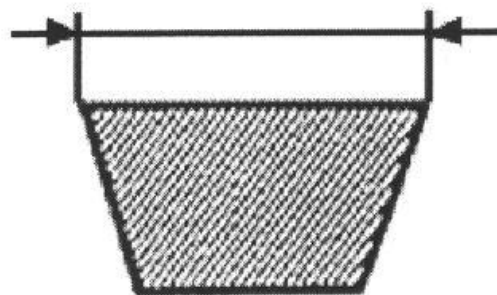

During the wear checks foreseen in the scheduled maintenance services, check that the rim bottom of the toothing does not show signs of incisions or cracking (see figure): The rim bottom of the tooth must not have incisions or cracking; if it does, change the belt.

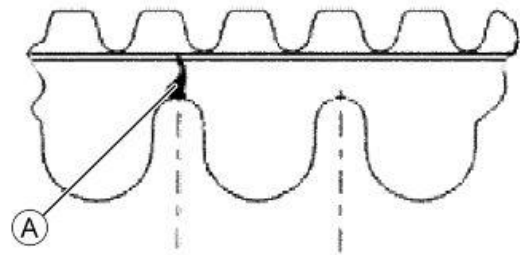

Removing the driving pulley

To remove the drive pulley, proceed as follows:

- Turn the crankshaft until the cavities of the pulley are on a vertical axis.

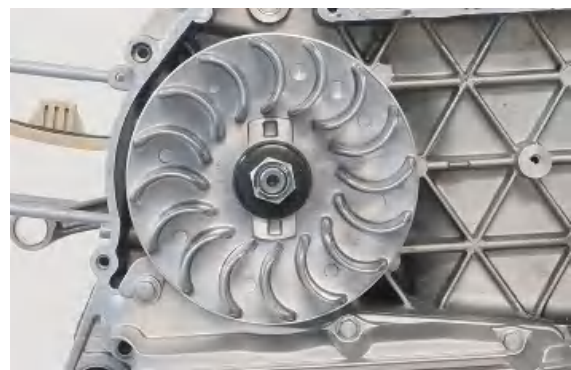

- Block the drive pulley using a specific tool.

Specific tooling

021021Y Drive pulley lock

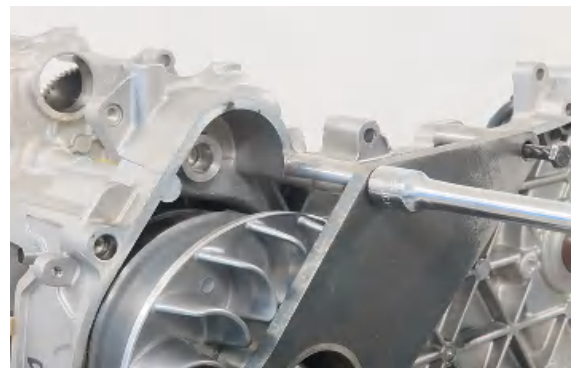

- Unscrew the pulley fixing nut.



- Unscrew the screws and remove the tool.



- Remove the nut, the spring washer and the flat washer.



- Remove the stationary drive pulley half



- Remove the entire roller housing.



Inspecting the rollers case

- Check that the internal bushing shown in the figure is not abnormally worn and measure inner diameter A.
- Measure outer diameter B of the pulley sliding bushing shown in the figure.
- Check that the rollers are not damaged or worn.
- Check the sliding shoes for the variator back-plate are not worn.
- Check the wear of the roller housings and of the belt facing surfaces on both pulley halves.
- Check that stationary driving pulley does not show signs of abnormal wear on the grooved edge and on the surface in contact with the belt.
- Check that the O-ring is not pushed out of shape.



CAUTION

DO NOT LUBRICATE OR CLEAN SINTERED BUSHINGS

Characteristic

Maximum allowable clearance of the mobile half-pulley bushing - sliding bushing

0.15 mm

Roller: Standard Diameter

Diameter 20.5 - 20.7 mm

Roller: Minimum diameter permitted

Ø 20 mm





Refitting the driving pulley

To fit the drive pulley, proceed as follows:

- Insert the entire roller housing.



- Insert the stationary drive pulley half



- Insert the flat washer, the spring washer and the nut.

- Pay specific attention to the orientation of the spring washer.

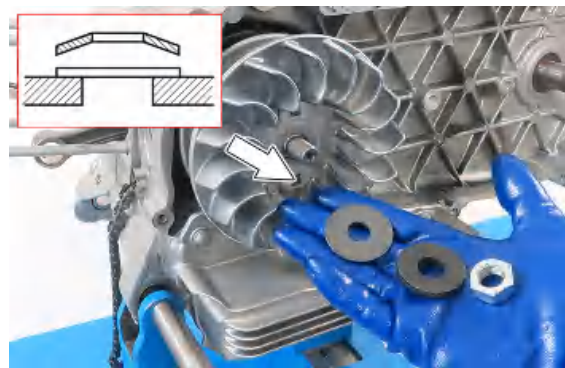

- Fit the specific tool.

Specific tooling

021021Y Drive pulley lock

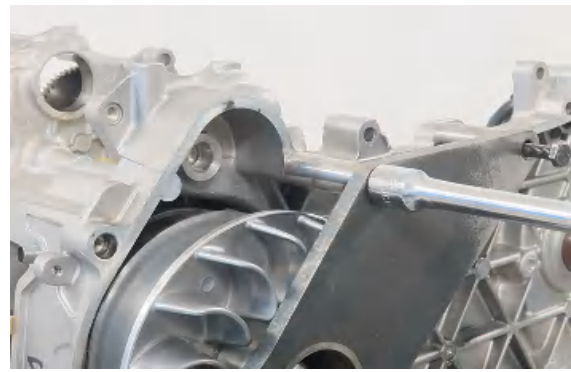

- Tighten the fixing nut to the specified torque.

Locking torques (N*m)

Stationary drive pulley - Crankshaft 79.0 ± 4.0 Nm



- Remove the special tool.

Specific tooling

021021Y Drive pulley lock



Refitting the transmission cover

- Make sure the alignment dowels are present.
- Put the transmission cover.



- Insert and tighten the fixing screws of the transmission cover to the prescribed torque.



- Put the washer and the fixing nut.



- Block clutch housing rotation using the appropriate tool.

Specific tooling

020423Y Driven pulley lock wrench



- Tighten the fixing nut to the specified torque.



End gear

Removing the hub cover

- Empty the rear hub through the oil drainage plug.
- Remove the 7 flanged screws indicated in the figure.
- Remove the hub cover and its gasket.

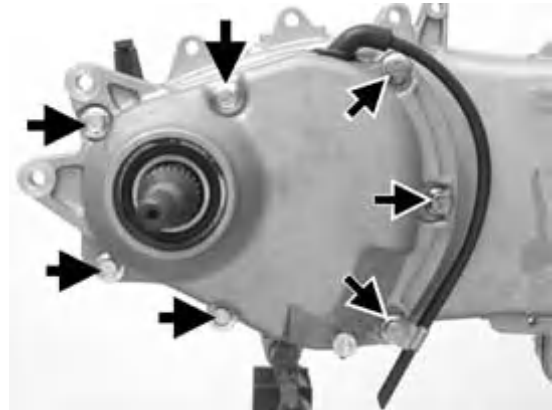

Removing the wheel axle

- Remove the wheel axle complete with gear.
- Remove the intermediate gear.

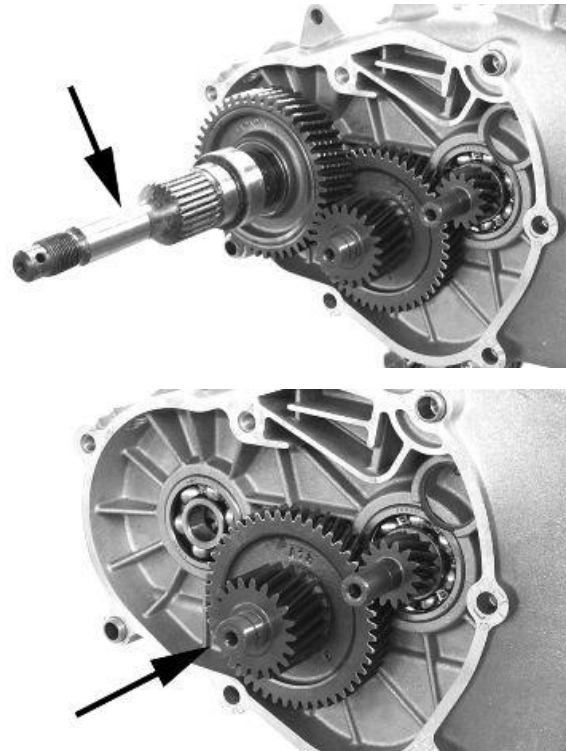

Removing the hub bearings

- Check the state of the bearings being examined (wear, clearance and noisiness). If faults are detected, do the following.
- Use the specific bearing extractor to remove the three 15 mm bearings (2 in the crankcase and 1 in the hub cover)

Specific tooling

001467Y013 Calliper to extract \varnothing 15-mm bearings



Removing the wheel axle bearings

- Take out the clip on the outside of the hub cover.
 - Support the hub cover and expel the bearing.
- By means of the appropriate tools, remove the oil seal as in the figure.

Specific tooling

020376Y Adaptor handle

020477Y Adapter 37 mm

020483Y 30-mm guide

020359Y 42 x 47 mm Adaptor

020489Y Hub cover support stud bolt kit



Removing the driven pulley shaft bearing

- As you need to remove the driven pulley shaft, its bearing and oil seal, remove the transmission cover as described above.
- Extract the driven pulley shaft from its bearing.
- Remove the oil seal using a screwdriver, working from inside the bearing and being careful not to damage the housing, make it come out of the belt transmission side.
- Remove the Seeger ring shown in the figure
- Remove the driven pulley shaft bearing using the modular punch.

Specific tooling

020376Y Adaptor handle

020375Y 28 x 30 mm adaptor

020363Y 20-mm guide

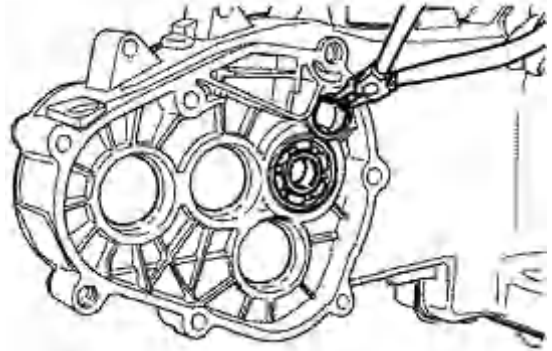

Inspecting the hub shaft

- Check the three shafts for wear or distortion of the toothed surfaces, the bearing housings, and the oil seal housings.
- If faults are found, replace the damaged components.

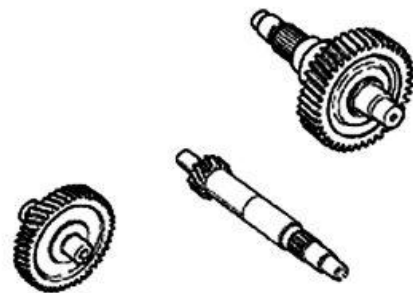

Inspecting the hub cover

- Check that the fitting surface is not dented or distorted.
 - Check the bearing bearings.
 - In case of faults, replace the damaged components.
-

Refitting the wheel axle bearing

- Support the hub cover on a wooden surface.
- Heat the crankcase cover with the specific heat gun.
- Fit the wheel shaft bearing with a modular punch as shown in the figure.
- Fit the Seeger ring.
- Fit the oil seal with seal lip towards the inside of the hub and place it flush with the internal surface by means of the appropriate tool used from the 52-mm side.

The 52-mm side of the adapter must be turned towards the bearing.

Specific tooling

020376Y Adaptor handle

020360Y 52 x 55 mm adaptor

020483Y 30-mm guide

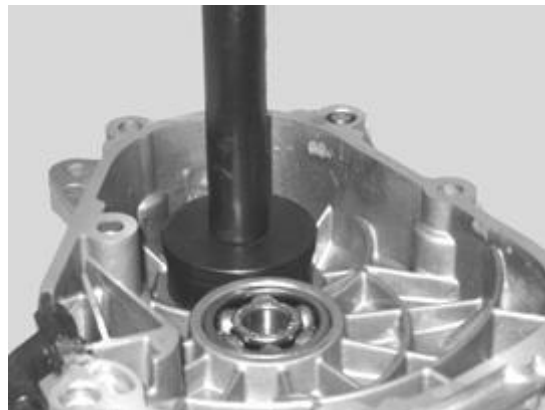

Refitting the hub cover bearings

In order to fit the hub box bearings, the engine crankcase and the cover must be heated with the special heat gun.

- The three 15-mm bearings must be fitted using the appropriate tools:
- The 42 mm side of the adaptor must be turned towards the bearing.

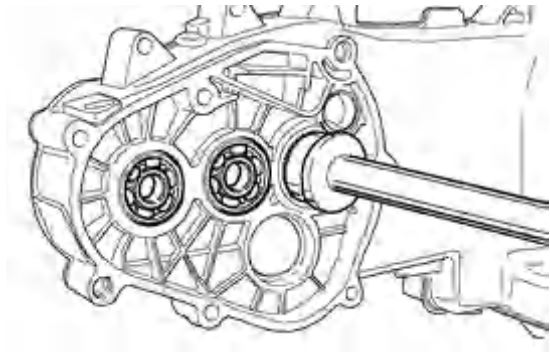

Specific tooling

020150Y Air heater mounting

020151Y Air heater

020376Y Adaptor handle

020359Y 42 x 47 mm Adaptor

020412Y 15-mm guide



N.B.

TO FIT THE BEARING ON THE COVER, ADEQUATELY SUPPORT THE COVER WITH THE STUD BOLT KIT.

- Refit the driven pulley shaft bearing with a modular punch as shown in the figure.

N.B.

IF THE BEARING HAS AN ASYMMETRICAL BALL RETAINER, PLACE IT SO THAT THE BALLS ARE VISIBLE FROM THE HUB INNER SIDE.

Specific tooling

020376Y Adaptor handle

020359Y 42 x 47 mm Adaptor

020363Y 20-mm guide



N.B.

WHEN FITTING THE BEARINGS ON THE ENGINE CRANKCASE, SUPPORT THE CRANKCASE PREFERABLY ON A SURFACE TO ALLOW THE BEARINGS TO BE DRIVEN VERTICALLY.

- Refit the Seeger ring with the opening facing the bearing and fit a new oil seal flush with the crankcase from the pulley side.

Refitting the hub bearings

- Assemble the 3 shafts in the engine crankcase as shown in the figure.



Refitting the ub cover

- Fit a new gasket together with the alignment dowels.
- Seal the gasket of the breather pipe using black silicone sealant.
- Fit the gearbox cover, making sure the breather pipe is in the correct position.
- Position the shorter screw that can also be recognised from the different colour as shown in the figure.
- Fix the breather tube support by means of the lower screw.
- Fit the remaining screws and tighten the seven screws to the prescribed torque.

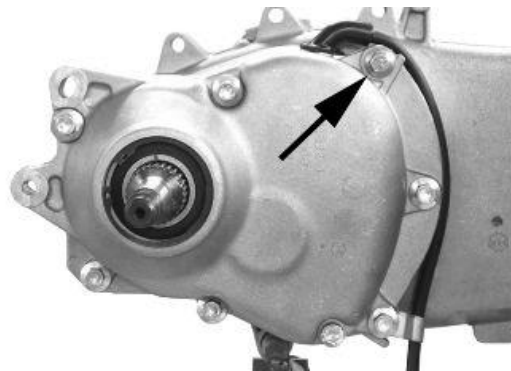
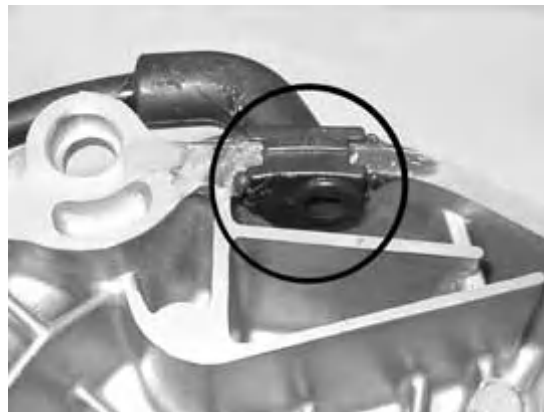

Flywheel cover

Removing the hub cover

To remove the flywheel cover, proceed as follows:

- Remove the clip fixing the sleeve to the cylinder.



- Remove the fixing screws of the flywheel cover.

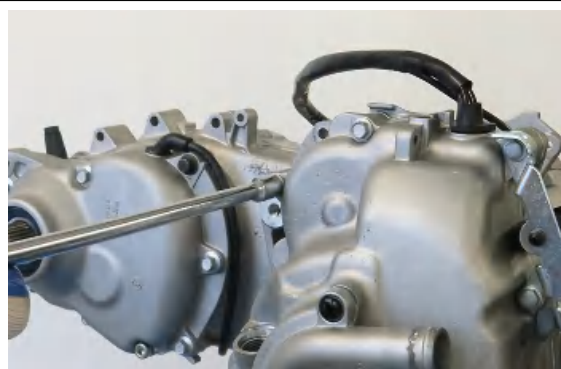

- Remove the flywheel cover.

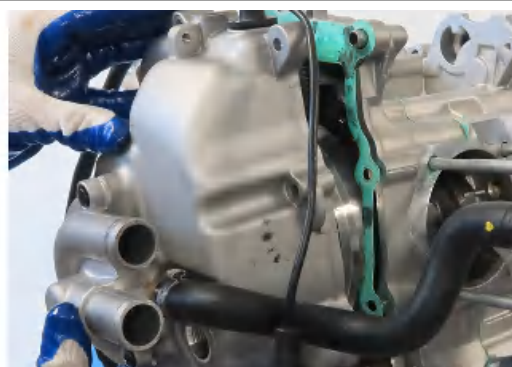

- Remove the keying spring of the water pump shaft.



- remove the cover gasket.



Removing the stator

- Remove the two pick-up screws and the screw holding the wiring support and the three stator clamping screws shown in the figure.
- Remove the stator and its cable harness.



Refitting the stator

- Refit the stator and flywheel carrying out the removal procedure in reverse, tightening the retainers to the specified torque.

Locking torques (N*m)

Stator assembly screws (°) 3 - 4



Refitting the flywheel cover

- Position the spline clip on the crankshaft and orient the end as shown in the figure.

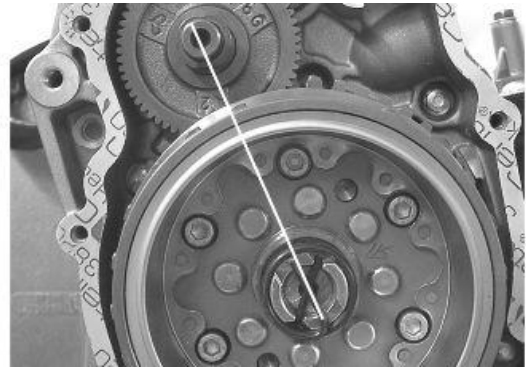

- Orient the water pump shaft with reference to the transmission gear seat as shown in the picture.

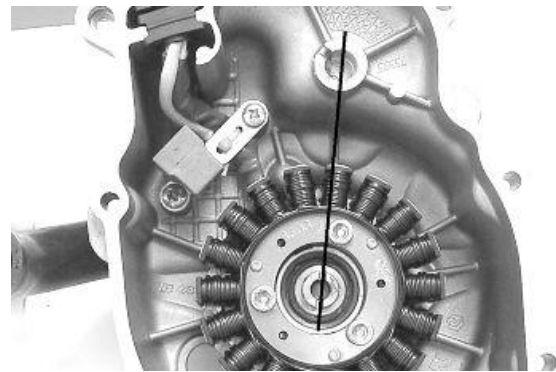

- Refit the cover over the engine and tighten the screws to the prescribed torque.
- Carry out the removal steps but in the reverse order.

CAUTION

TAKE CARE TO CORRECTLY POSITION THE FLYWHEEL CONNECTOR. MAKE SURE THE CENTRING DOWELS ARE PRESENT.

Locking torques (N*m)

Flywheel cover screws 11 - 13

Flywheel and starting

Removing the starter motor

- Disconnect the positive connector for electrical system connection to the starter motor.



- Unscrew the starter motor's fixing screws.

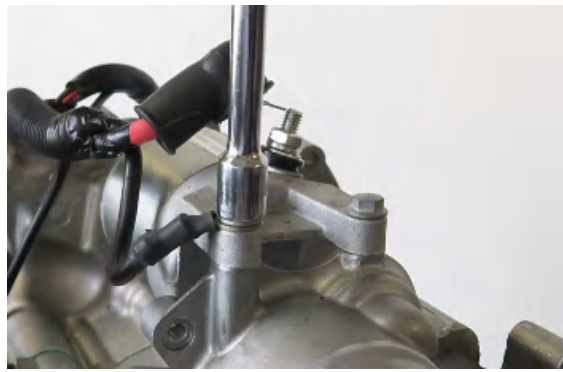

- Remove the screws and the negative connector.



- Remove the starter motor.



Removing the flywheel magneto

- Remove the water pump shaft and crankshaft spline clip



-
- Line up the two holes in the flywheel as shown in the picture

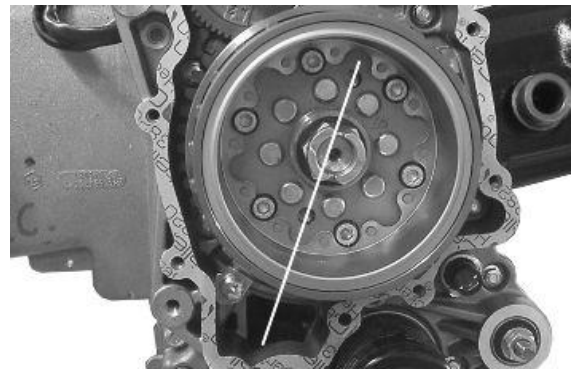

-
- Screw in the guide bushing that is part of the special flywheel stop tool on the flywheel as shown in the picture



-
- Insert the special flywheel stop tool on the flywheel as shown in the picture

Specific tooling

020627Y Flywheel lock tool



-
- Remove the flywheel nut with its washer
 - Do up the flywheel nut by three or four threads so that the flywheel does not fall accidentally on extraction
 - Screw the extractor onto the flywheel and extract it as shown in the picture

Specific tooling

020467Y Flywheel extractor



Inspecting the flywheel components

- Check the integrity of the internal plastic parts of the flywheel and the Pick-up control plate.
-

Refitting the free wheel

- Make sure the freewheel contact surfaces are in good condition.
- Thoroughly clean the free wheel to remove LOCTITE residue.
- Degrease the threading of the holes in the free wheel and the clamping screws.
- Apply the recommended product to the end of the screws.

Recommended products

Loctite 243 Medium strength thread-locking sealant.

Blue

- Fit the freewheel on the magneto flywheel making sure that the ground side is in contact with the flywheel itself, i.e. with wheel Seeger ring visible.
- Lock the six clamping screws in criss-cross fashion to the prescribed torque.



Locking torques (N*m)

Screw fixing freewheel to flywheel 13 - 15

- Oil the free wheel "rollers".



Refitting the flywheel magneto

- Insert the free wheel on the flywheel as shown in the picture
- Then refit the flywheel with free wheel and transmission gear



- Using the special flywheel lock wrench, tighten up the flywheel fixing nut to the prescribed torque
- Refit the retention plate



Specific tooling

020627Y Flywheel lock tool

Locking torques (N*m)

Flywheel nut 94 - 102

Refitting the starter motor

- Insert the starter motor in its seat.



- Insert the fixing screws and the negative connector.



- Tighten the starter motor fixing screws to the recommended torque.

Locking torques (N*m)

Starter motor - Crankcase $12,0 \pm 1,0$



- Connect the positive connector for electrical system connection to the starter motor.



Cylinder assy. and timing system

Removing the intake manifold

- Remove the throttle body and the injector.
- Unscrew the manifold fastening screws.



- Remove the fixing screws.



- Remove the manifold.



-
- Remove the gasket.



Removing the rocker-arms cover

- Remove the 5 screws indicated in the figure

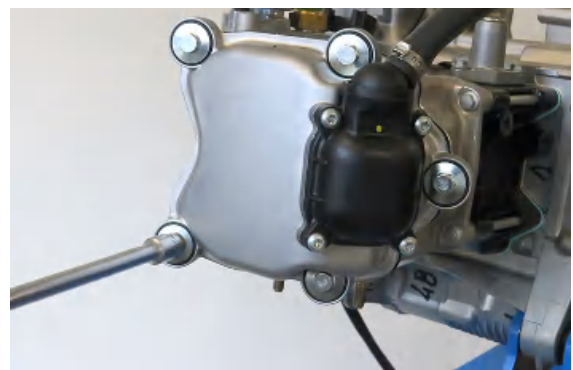

Removing the timing system drive

First remove the parts listed below:

- Transmission cover
 - Driving pulley
 - Oil sump
 - Oil pump pulley cover
 - O-ring from the crankshaft and the pinion separating washer
- Remove the tappet cover.
 - Undo the central screw.

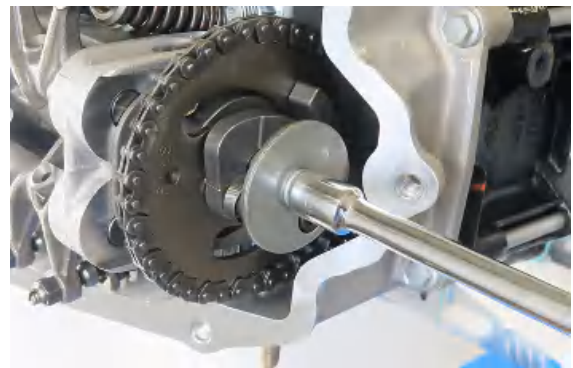

- Remove the central screw and the washer.

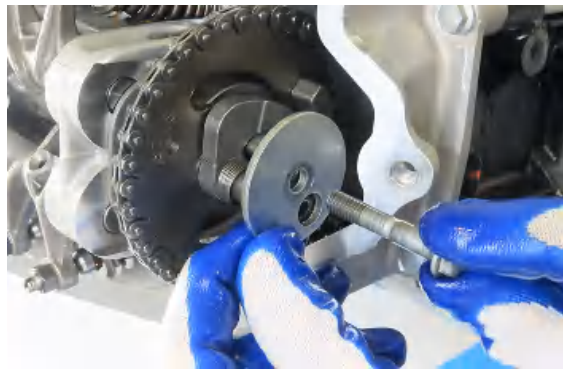

- Unscrew and remove the screw fastening the counterweight.

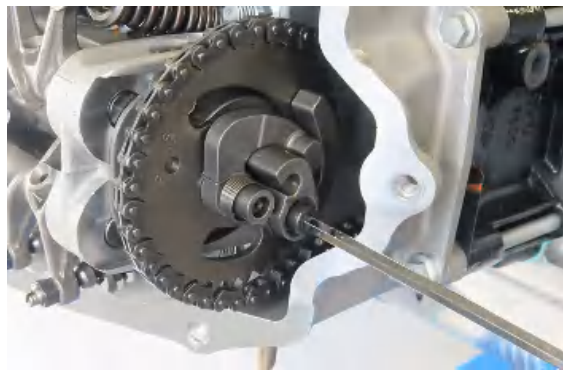

- Remove the spring and the counterweight.

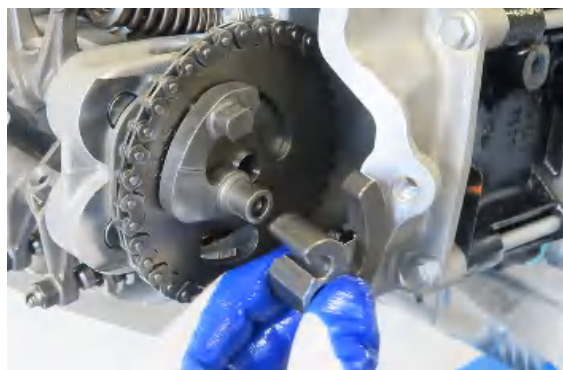

Remove the decompression counterweight.

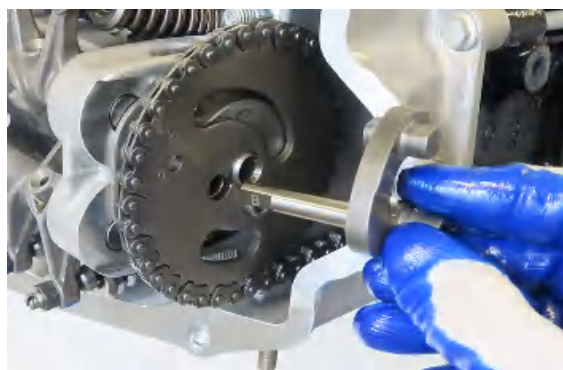

- Remove the distribution system's screw plug.

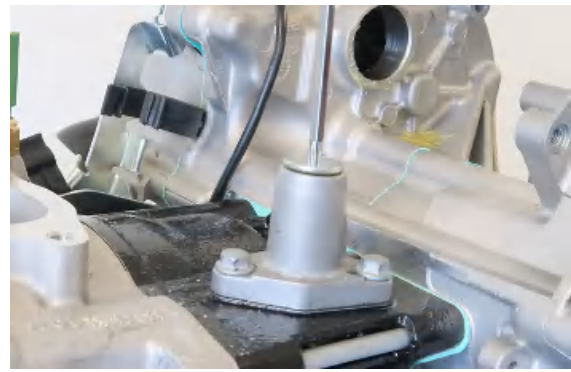

- Using a small screwdriver, loosen the chain tensioner by turning anticlockwise.



- Remove the timing system sprocket.

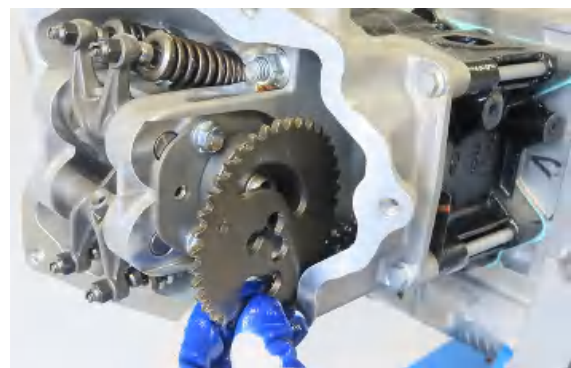

- Remove the control sprocket wheel and the timing chain.

- Remove the screws indicated in the figure, the spacer bar and the tensioner slider.

The tensioner pad must be removed from the transmission side. As regards the lower chain guide slider, it may only be removed after the head has been removed.

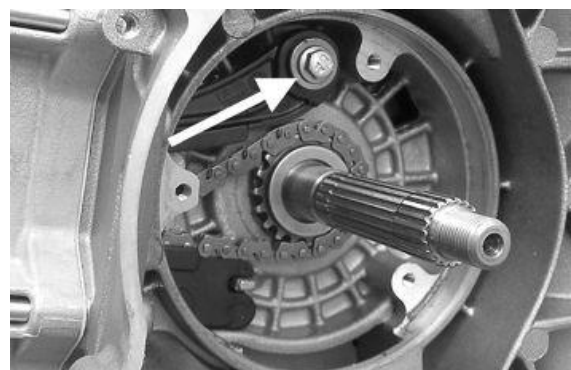

N.B.

IT IS ADVISABLE TO MARK THE CHAIN IN ORDER TO ENSURE THAT THE INITIAL DIRECTION OF ROTATION IS MAINTAINED

Removing the cam shaft

To remove the camshaft proceed as follows:

- Remove the tappet cover.
- Remove the timing system sprocket.
- Unscrew and remove the fixing screws of the camshaft retaining bracket.

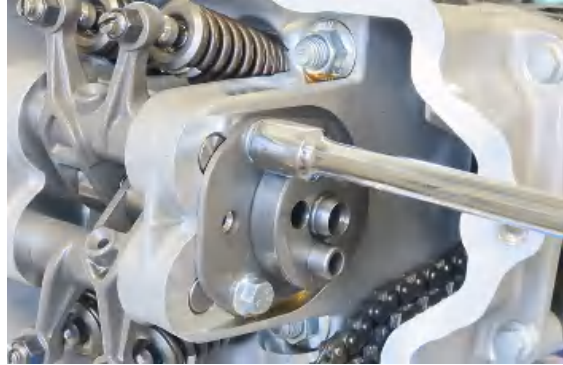

- Remove the camshaft retaining plate.

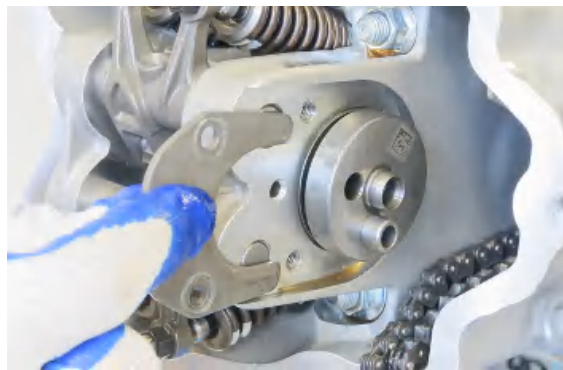

- Remove the camshaft.

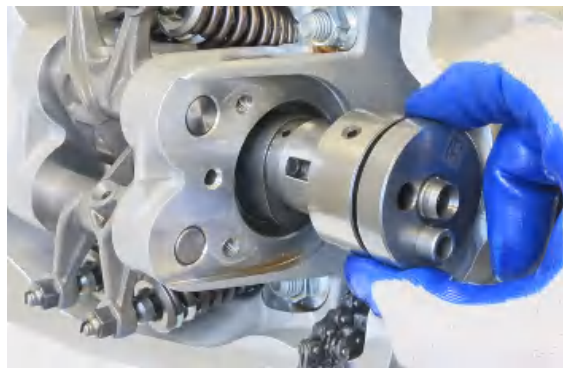

- Remove the rocker pins.

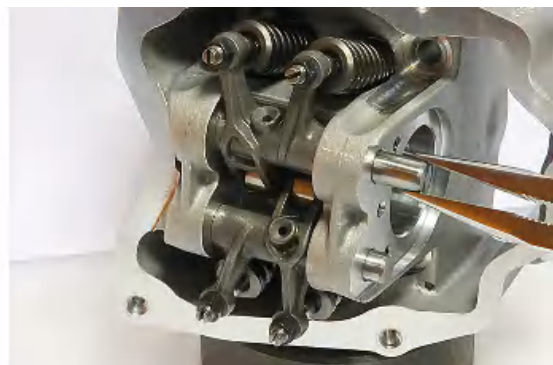

- Remove the rockers.



Removing the cylinder head

- Remove the tappet cover.
- Remove the timing system components.
- Remove the spark plug.



- Unscrew and remove the fixing screws on the timing system side.



- Operating in crossed sequence and in several stages, loosen the fixing nuts of the head.

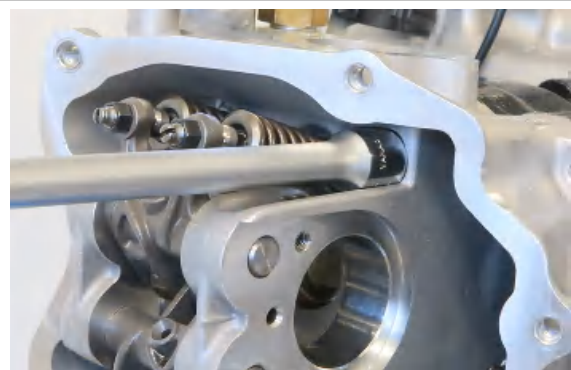

- Remove the cylinder head.

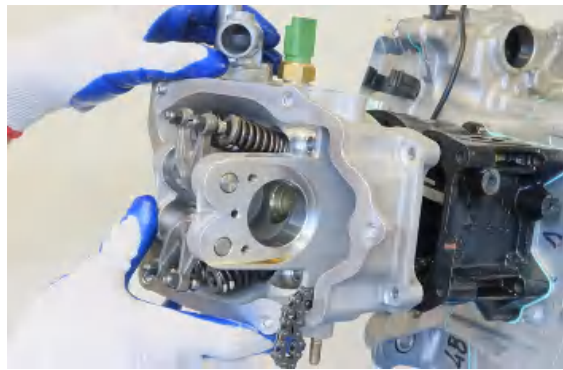

Removing the valves

- Using the appropriate tool fitted with an adaptor, remove the cotters, caps, springs and valves.
- Remove the oil guards with the appropriate tool
- Remove the lower spring supports.

CAUTION

REPLACE THE VALVES IN SUCH A WAY AS TO RECOGNISE THEIR ORIGINAL POSITION ON THE HEAD.

Specific tooling

020382Y011 adapter for valve removal tool

020382Y Valve cotters equipped with part 012 removal tool

020431Y Valve oil seal extractor



Removing the cylinder - piston assy.

To remove the cylinder and the piston, proceed as follows:

- Remove the cylinder head.



- Remove the chain tensioner sliding shoe.



- Remove the alignment dowels and the O-Rings.



- Remove the clamp and disconnect the sleeve of the cooling system.



- Pull out the cylinder.

CAUTION
TO PREVENT DAMAGING THE PISTON, SUPPORT IT
WHILE REMOVING THE CYLINDER.

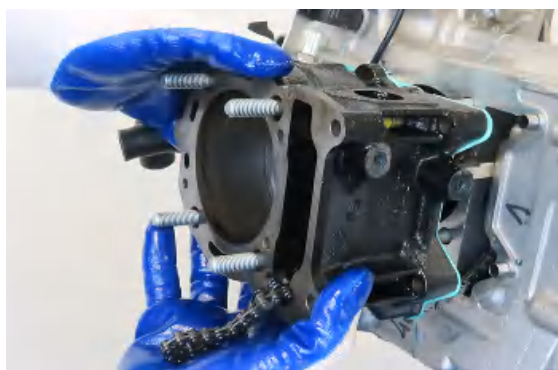

- Remove the piston.

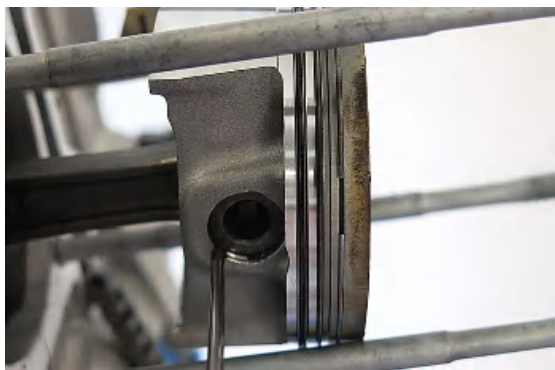

Inspecting the small end

N.B.

TO MEASURE WEAR LIMITS AND COUPLING CLEARANCES, SEE THE SPECIFICATIONS CHAPTER.

See also

[Crankcase - crankshaft - connecting rod](#)

Inspecting the wrist pin

N.B.

TO MEASURE WEAR LIMITS AND COUPLING CLEARANCES, SEE THE SPECIFICATIONS CHAPTER.

See also

[Cylinder - piston assy.](#)

Inspecting the piston

N.B.

TO MEASURE WEAR LIMITS AND COUPLING CLEARANCES, SEE THE SPECIFICATIONS CHAPTER.

See also

[Cylinder - piston assy.](#)

Inspecting the cylinder

N.B.

TO MEASURE WEAR LIMITS AND COUPLING CLEARANCES, SEE THE SPECIFICATIONS CHAPTER.

See also

[Cylinder - piston assy.](#)

Inspecting the piston rings

N.B.

TO MEASURE WEAR LIMITS AND COUPLING CLEARANCES, SEE THE SPECIFICATIONS CHAPTER.

See also[Piston rings](#)**Removing the piston**

- Fit the piston and wrist pin onto the connecting rod, aligning the piston arrow the arrow facing towards the exhaust.
- Fit the pin retainer ring onto the appropriate tool
- With opening in the position indicated on the tool
S = left
D= right
- Place the wrist pin retainer ring into position using a punch.
- Fit the pin retainer ring using the plug as shown in the figure.

N.B.

THE TOOL FOR INSTALLING THE RETAINER RINGS MUST BE USED MANUALLY.

CAUTION

USING A HAMMER MIGHT DAMAGE THE STOPS' HOUSING.

Specific tooling

020454Y Tool for fitting the pin snap rings

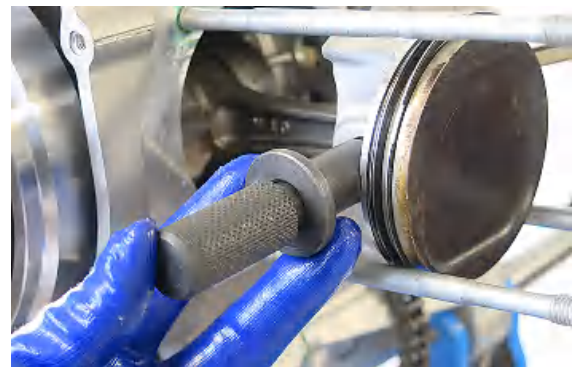
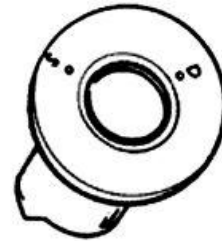
**Choosing the gasket**

- Provisionally fit the piston into the cylinder, without any base gasket.
- Assemble a dial gauge on the specific tool.

Specific tooling

020428Y Piston position check mounting

- Using an abutment plane, reset the dial gauge with a pre-load of a few millimetres.
- Finally fix the dial gauge.
- Check the perfect sliding of the feeler pin.
- Install the tool on the cylinder without changing the dial gauge position.
- Lock the tool using the original head fixing nuts.
- Turn the crankshaft to TDC (point at which dial gauge reading reverses).
- Measure the deviation from the reset value.



- By means of the table, see the Specifications chapter identify the cylinder base gasket thickness to be used for refitting. Correctly identify the cylinder base gasket thickness to keep the correct compression ratio.
- Remove the special tool and the cylinder.

N.B.

IF DEVIATIONS (PROTRUSIONS OR RECESSES) CLOSE TO THE CHANGE OF CATEGORY ARE MEASURED, REPEAT THE MEASUREMENT AT THE OPPOSITE SIDE. TO DO SO, REPEAT THE TOOL FITTING OPERATION, INVERTING ITS POSITION.

See also

[Slot packing system](#)

Refitting the piston rings

- Place the scraper ring spring on the piston.
- Install the scraper ring keeping the opening opposed to the spring junction and with the writing "top" facing the piston crown. The chamfered side of the oil scraper ring should always be facing the piston crown.
- Fit the second lining with the identification letter or the writing "top" facing the piston crown. In any case, the step must be facing opposite the piston crown.
- Install the first compression ring in the direction imposed by the housing.
- It is advisable to use a fitter to facilitate the installation of the linings.

**N.B.**

THE TWO PISTON RINGS ARE MADE WITH A TAPERED CYLINDRICAL CONTACT CROSS-SECTION. THIS IS TO ACHIEVE A BETTER BEDDING.

- Misalign the lining openings at 120° as shown in the figure.
 - Lubricate the components with engine oil.
 - The engine uses the first compression lining with an L section.
-

Refitting the cylinder

- Insert the cylinder base gasket with the thickness determined above.
- Using the fork support and the piston ring retaining band, refit the cylinder as shown in the figure.

N.B.

BEFORE FITTING THE CYLINDER, CAREFULLY BLOW OUT THE LUBRICATION DUCT AND OIL THE CYLINDER BARREL.

Specific tooling

020426Y Piston fitting fork

020393Y Piston fitting ring

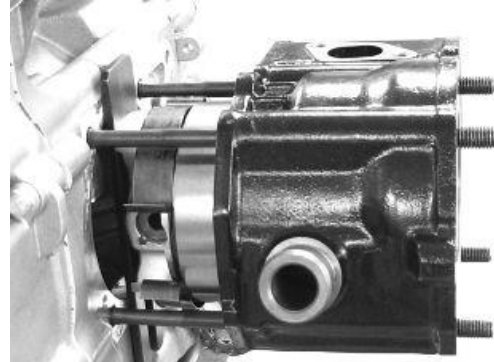

Inspecting the cylinder head

N.B.

TO MEASURE WEAR LIMITS AND COUPLING CLEARANCES, SEE THE SPECIFICATIONS CHAPTER.

See also

[Cylinder Head](#)

Inspecting the timing system components

- check that the fixed chain tensioner sliding shoe and the mobile chain tensioner sliding shoe are not excessively worn.
- Check that the pinion, the chain and the timing system sprocket are not excessively worn.
- If they are, replace them.

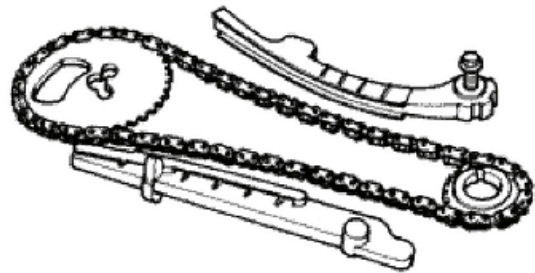

- check the correct operation of the tensioner; once opened, press to check that the plunger does not return.



Inspecting the valve sealings

N.B.

TO MEASURE WEAR LIMITS AND COUPLING CLEARANCES, SEE THE SPECIFICATIONS CHAPTER.

See also

[Cylinder Head](#)

Inspecting the valves

N.B.

TO MEASURE WEAR LIMITS AND COUPLING CLEARANCES, SEE THE SPECIFICATIONS CHAPTER.

See also

[Cylinder Head](#)

Inspecting the springs and half-cones

- Check that the upper and lower supporting spring washers, the cotters and the oil seal show exhibit no signs of abnormal wear. Replace a component when worn.

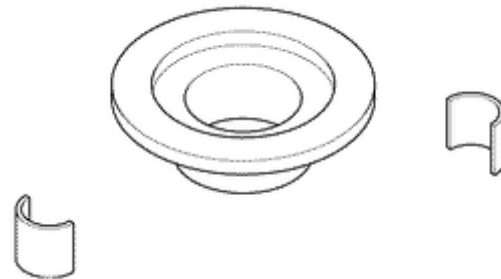

- Measure the unloaded spring length.

N.B.

TO MEASURE WEAR LIMITS AND COUPLING CLEARANCES, SEE THE SPECIFICATIONS CHAPTER.

See also

[Cylinder Head](#)

Refitting the valves

- Lubricate the valve guides with engine oil.
- Place the valve spring supports on the head.
- Using the special punch, fit the four valve seal rings.
- Fit the valves, the springs and the caps. Using the appropriate tool with adapter, compress the springs and insert the cotters in their seats.

N.B.



DO NOT CHANGE THE VALVE FITTING POSITION. FIT THE VALVE SPRINGS WITH THE REFERENCE COLOUR ON COTTER SIDE (TURNS WITH GREATER PITCH).

Specific tooling

020306Y Punch valve seal rings fitting

020382Y Valve cotters equipped with part 012 removal tool

020382Y011 adapter for valve removal tool



Inspecting the cam shaft

N.B.

TO MEASURE WEAR LIMITS AND COUPLING CLEARANCES, SEE THE SPECIFICATIONS CHAPTER.

See also

[Cylinder Head](#)

Refitting the head and timing system components

- Fit the control pinion and the timing chain on the crankshaft.
- Insert the mobile chain tensioner sliding shoe.
- Insert the fastening screw and tighten to the specified torque.



Locking torques (N*m)

Mobile chain tensioner sliding shoe - Crankcase 12.0 ± 1.0 Nm

- Lubricate the O-rings and insert them on the stud bolts



-
- Insert the fixed chain tensioner sliding shoe.



-
- Insert the two alignment dowels between the head and the cylinder.



-
- Insert the head gasket.

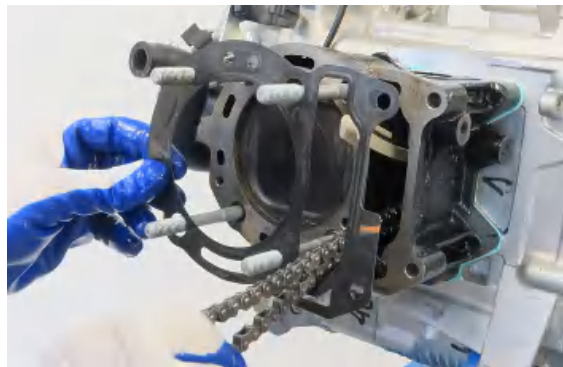

-
- Insert the head.

N.B.

BEFORE INSTALLING THE HEAD, MAKE SURE THAT THE LUBRICATION CHANNEL IS CLEAN USING A COMPRESSED AIR JET.



- Lubricate the stud bolt threading.
- Fit the head fixing nuts.
- Following the order shown in the figure, tighten the head fixing nuts to the prescribed torque.

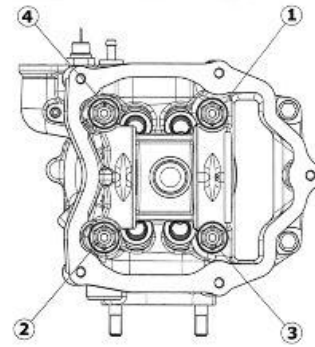

Locking torques (N*m)

Head - Cylinder (pre-stage) 7.0 ± 1.0 Nm Head - cylinder 10.0 ± 1.0 Nm Head - Cylinder (Angle rotation) 270°

- Insert the screws on the timing system chain side and tighten them to specified torque.

Locking torques (N*m)

Head - Crankcase 12.0 ± 1.0 Nm



- Lubricate the two housings and insert the camshaft in its seat with the cam teeth opposing the rockers.

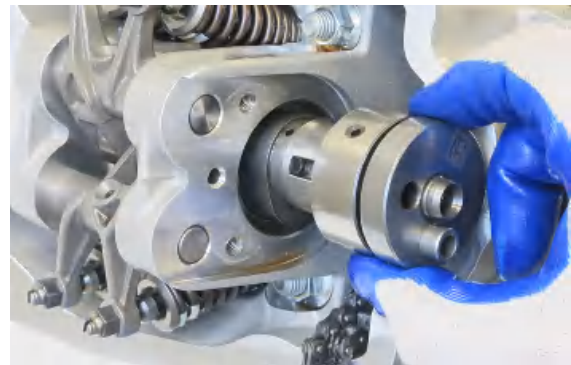

- Insert the camshaft retaining plate.

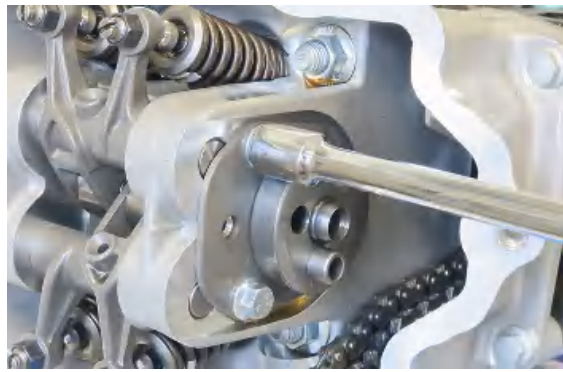

-
- Insert and tighten the camshaft retaining plate fixing screws, applying the recommended torque.

Locking torques (N*m)**Camshaft retaining plate - Head 5.0 ± 1.0 Nm**

-
- Bring the piston to the TDC by aligning the reference marks on the flywheel and the flywheel cover.



-
- Fit the timing system sprocket.

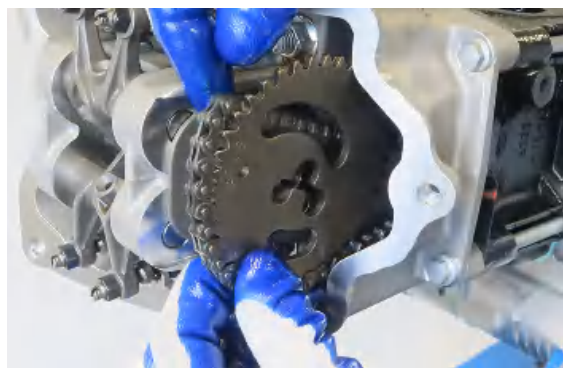

-
- Align the reference marks on the sprocket and head, without moving the timing chain.



- Insert the decompression counterweight.

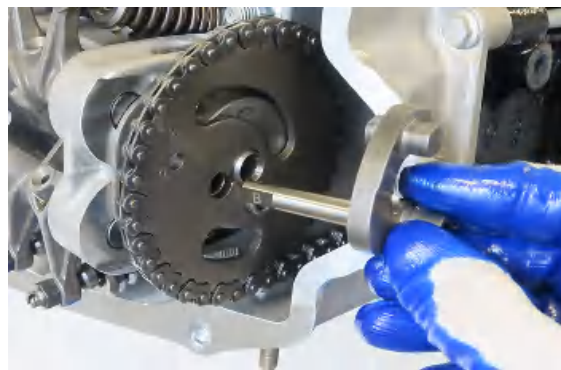

- Fit the counterweight.

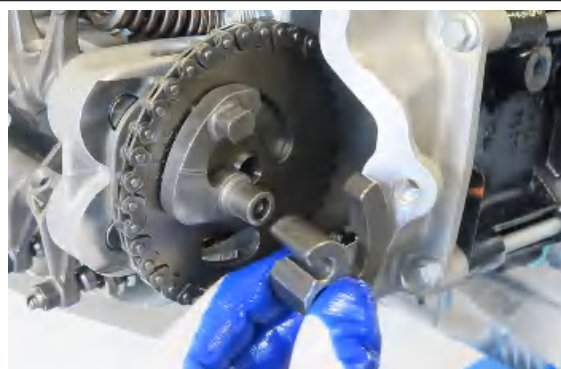

- Pre-load the spring and insert it in its seat.



- Insert the screw fastening the counterweight and tighten to the specified torque.

Locking torques (N*m)

Decompression counterweight - Camshaft 8.0 ± 1.0 Nm

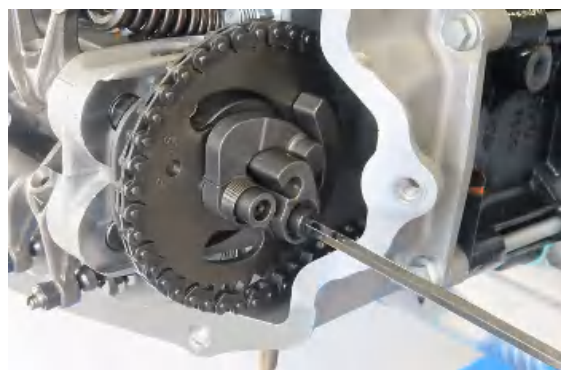

- Fit the washer.
- Insert the fixing screw and tighten to the specified torque.

Locking torques (N*m)

Compression release weight - Camshaft 13.0 ± 2.0 Nm

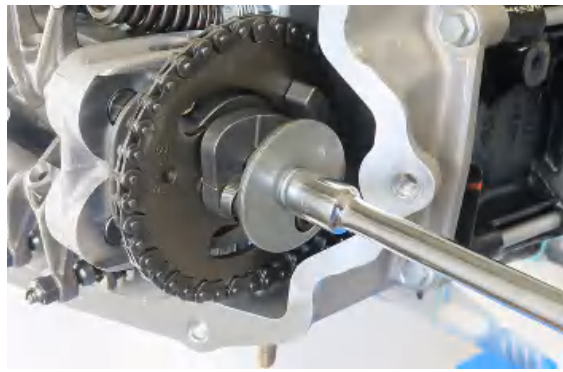
**Refitting the rocker-arms cover**

- Fit the tappet cover paying particular attention to the correct positioning of the gasket.



- Insert and tighten the fixing screws, applying the recommended torque.

Locking torques (N*m)

Tappet cover - Head 6.5 ± 1.0 Nm

**Refitting the intake manifold**

- Fit a new gasket.



-
- Put the manifold.



-
- Insert the fastening screws



-
- Tighten the manifold fixing screws to the prescribed torque.
 - Refit the throttle body and the injector.

Locking torques (N*m)

Intake manifold - Head 12.0 ± 1.0 Nm



Crankcase - crankshaft

Splitting the crankcase halves

-
- Before opening the crankcase, it is advisable to check the axial clearance of the crankshaft. To do this, use a plate and a support with appropriate tool dial gauge.
 - Upper clearances are an indication of wear on the surfaces of the crankshaft casing support.
 - Remove the 10 crankshaft coupling screws.

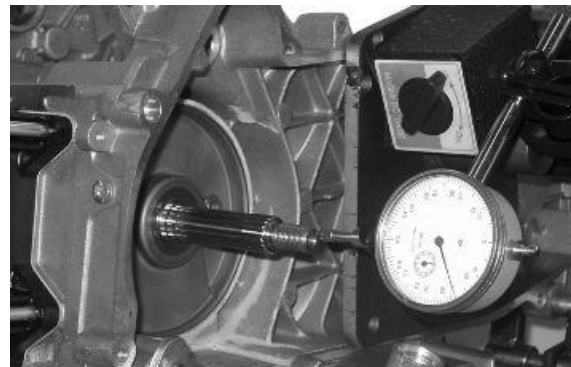

- Separate the crankcase while keeping the crankshaft in one of the two halves of the crankcase.
- Remove the crankshaft.
- Remove the half crankcase coupling gasket.
- Remove the two screws and the internal shield shown in the diagram.
- Remove the oil seal on the flywheel side.
- Remove the oil filter fitting shown in the diagram.
- Check the axial clearance on the connecting rod.
- Check the radial clearance on the connecting rod.
- Check the surfaces that limit the axial free-play are not scored and measure the width of the crankshaft between these surfaces, as shown in the diagram.
- If the axial clearance between crankshaft and crankcase is exceeding and the crankshaft does not have any defect, the problem must be due to either excessive wear or wrong machining on the crankcase.
- Check the diameters of both the bearings of the crankshaft in accordance with the axes and surfaces shown in the figure. The half-shafts are classified in two categories Cat. 1 and Cat. 2 as shown the chart below.

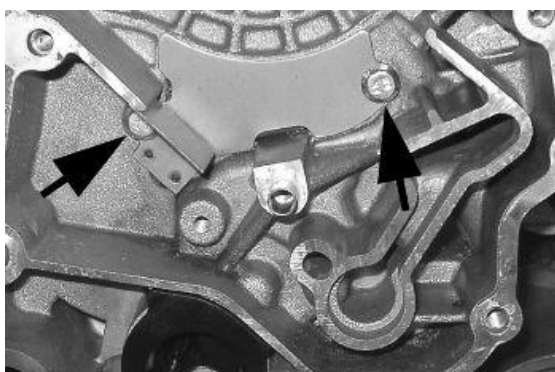
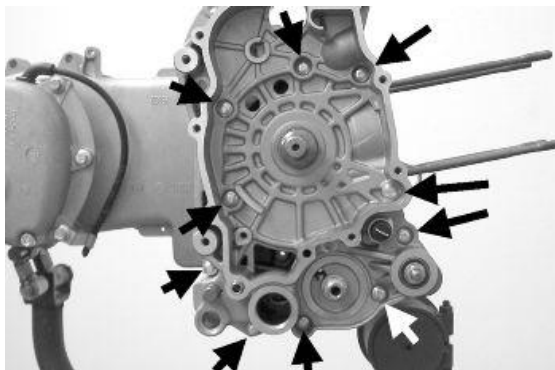
**CAUTION**

THE CRANKSHAFT CAN BE REUSED WHEN THE WIDTH IS WITHIN THE STANDARD VALUES AND THE SURFACES SHOW NO SIGNS OF SCORING.

CAUTION

WHILE OPENING THE CRANKCASES AND REMOVING THE CRANKSHAFT, CHECK THAT THE THREADED SHAFT ENDS DO NOT INTERFERE WITH THE MAIN BUSHINGS. FAILURE TO OBSERVE THIS PRECAUTION CAN DAMAGE THE MAIN BUSHINGS.

CAUTION

KEEP THE CRANKSHAFT IN ONE OF THE TWO HALVES OF THE CRANKCASE WHEN SEPARATING IT. IF YOU FAIL TO DO THIS, THE CRANKSHAFT MIGHT ACCIDENTALLY FALL.

N.B.

WHEN MEASURING THE WIDTH OF THE CRANKSHAFT, MAKE SURE THAT THE MEASUREMENTS ARE NOT MODIFIED BY THE RADIUS OF FITTINGS WITH THE CRANKSHAFT BEARINGS.

N.B.

TO MEASURE WEAR LIMITS AND COUPLING CLEARANCES, SEE THE SPECIFICATIONS CHAPTER.

See also

[Crankcase - crankshaft - connecting rod](#)

Inspecting the crankshaft alignment

N.B.

TO MEASURE WEAR LIMITS AND COUPLING CLEARANCES, SEE THE SPECIFICATIONS CHAPTER.

See also

[Crankcase - crankshaft - connecting rod](#)

Inspecting the crankcase halves

- Before proceeding to check the crankcase halves, thoroughly clean all surfaces and oil ducts.
- On the transmission-side crankcase half, take particular care when handling the oil pump compartment and the oil ducts, the by-pass duct, the main bushings and the cooling jet on the transmission side (see diagram).
- Take particular care, also, that there are no signs of wear in the oil by-pass valve housing (see Chapter Lubrication), as this could prevent a good seal in the piston, which regulates the oil pressure.
- On the flywheel side crankcase half, take particular care cleaning the oil ducts for the main bushings, the oil duct for the jet that lubricates the cylinder head and the oil drainage duct at the flywheel side oil seal.
- Inspect the coupling surfaces on the crankcase halves for scratches or deformation, taking particular care with the cylinder/crankcase surfaces and the crankcase halves surfaces.
- Defects in the crankcase coupling gasket between the crankcase halves or the mating surfaces shown in the diagram, could cause a drop in the oil pressure lubricating the main bushings and connecting rod.

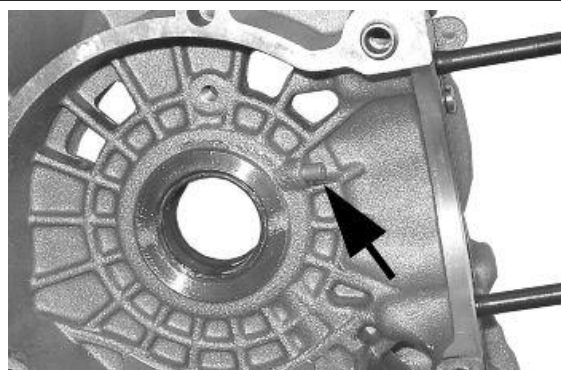

- Check the main bearing seats that limit axial clearance in the crankshaft show no signs of wear. The dimension between these seats is measured by way of the procedure described previously for measuring the crankshaft axial clearance and dimensions.

N.B.

THE JET IS FED THROUGH THE MAIN BUSHINGS. PROPER OPERATION OF THIS COMPONENT IMPROVES PISTON CROWN COOLING. CLOGGING HAS EFFECTS THAT ARE DIFFICULT TO DETECT (PISTON TEMPERATURE INCREASE). FAILURE OR LEAKS CAN CAUSE A CONSIDERABLE DROP IN THE LUBRICATION PRESSURE FOR MAIN BUSHINGS AND CONNECTING ROD.

N.B.

THE HEAD LUBRICATION CHANNEL IS PROVIDED WITH A SHUTTER JET; THIS GIVES A "LOW PRESSURE" HEAD LUBRICATION; THIS CHOICE WAS MADE TO REDUCE THE OIL TEMPERATURE IN THE SUMP. THE JET CLOGGING IMPAIRS THE HEAD LUBRICATION AND THE TIMING MECHANISMS. A JET FAILURE CAUSES A DECREASE OF THE MAIN BUSHING AND CONNECTING ROD LUBRICATION PRESSURE.

Inspecting the crankshaft plain bearings

- To obtain a good bushing lubrication it is necessary to have both an optimal lubricating pressure and a good oil flow rate; the bushings must be correctly positioned so as not to obstruct the oil supply channels.
- The main bushings are comprised of two half-bearings, one with holes and channels for lubrication whereas the other is solid.

Characteristic**Lubrication pressure**

3.5 - 4 bar

- The solid half-bearing is intended to stand the thrusts caused by combustion, and for this reason it is arranged opposite the cylinder.
- To prevent shutters in the oil feeding channels, the matching surface of the two half-bearings must be perfectly orthogonal to the cylinder axis, as shown in the figure.
- The oil feeding channel section is also affected by the bushings driving depth compared with the crankshaft axial clearance of the limiting surface.

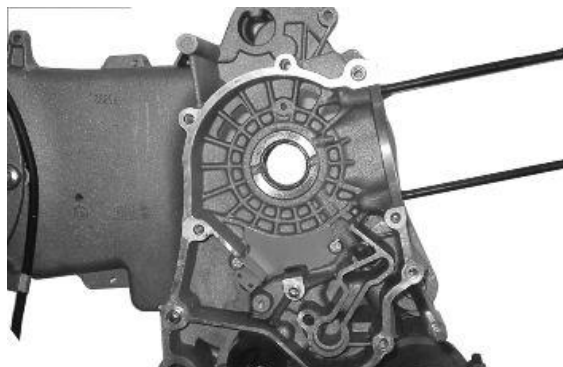
**N.B.**

TO MEASURE WEAR LIMITS AND COUPLING CLEARANCES, SEE THE SPECIFICATIONS CHAPTER.

See also[Crankcase - crankshaft - connecting rod](#)**Refitting the crankcase halves**

- Fit the internal shield by locking the two screws to the prescribed torque.
- Fit the oil filter fitting and tighten it to the prescribed torque
- Position the oil pre-filter element as shown in the picture.
- Place a new gasket on one of the crankcase halves, preferably on the transmission side, together with the alignment dowels.
- Lubricate the main bushings and insert the crankshaft in the transmission side crankcase half.
- Reassemble both crankcase halves.
- Fit the 10 screws and tighten them to the specified torque.
- Fit a new O-ring on the pre-filter and lubricate it.
- Insert the filter on the engine with the relative cap. Tighten to the prescribed torque.

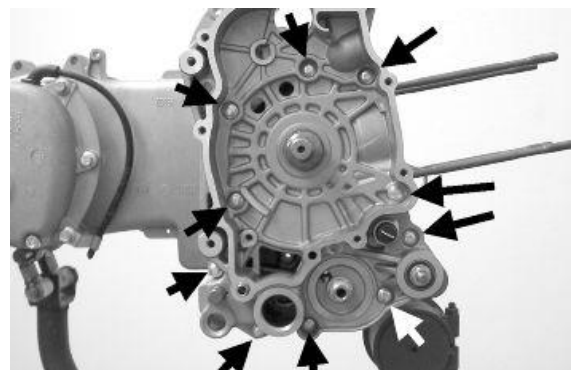
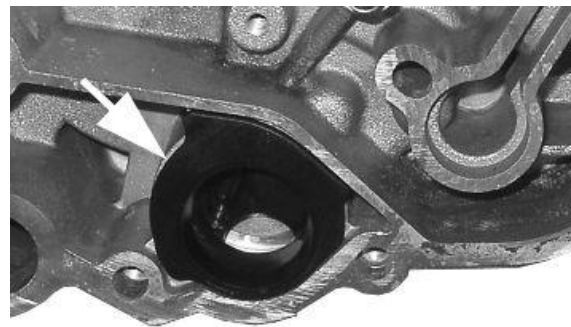
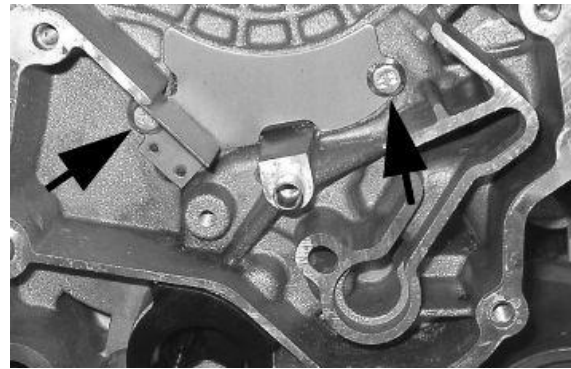
**Locking torques (N*m)**

Internal engine crankcase bulkhead (transmission-side half shaft) screws 4 - 6 Engine-crankcase coupling screws 11 to 13 Oil filter on crankcase fitting 27 - 33 Engine oil drainage plug/ mesh filter 24 to 30



Studs

Check that the stud bolts have not worked loose from their seat in the crankcase.

Check the depth of stud bolt driving with a gauge, as indicated in the picture. If it varies significantly from the driving depth indicated, it means that the stud bolt has yielded.

In this case, replace it.



By working on two fitted cylinder head fixing nuts, nut and lock nut, as shown in the picture, remove the stud bolt from its seat.

Clean the threaded seat on the carter thoroughly. Refit a new stud bolt and apply the special product on the threading crankcase side.

Tighten up to the depth of the driving indicated.



Recommended products

Loctite 270 High resistant threadlock.

green

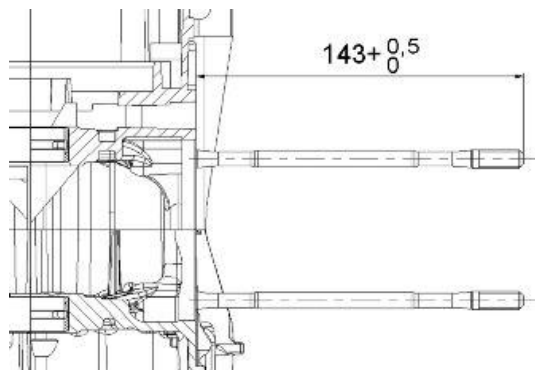

Lubrication

Locking torques (N*m)Minimum oil pressure sensor 12 - 14

Crankshaft oil seals

Removal

- Remove the transmission cover and the complete drive pulley beforehand

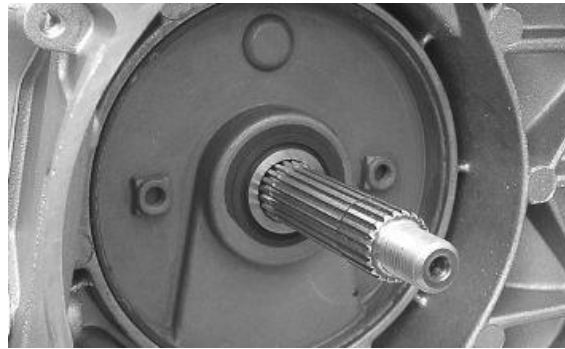

- Install the base of the appropriate tool on the oil seal using the screws provided

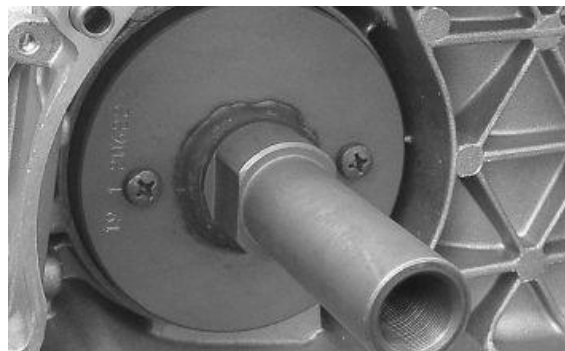
Specific tooling**020622Y Transmission-side oil seal punch**

- Screw the threaded bar onto the base of the tool and extract the oil seal.

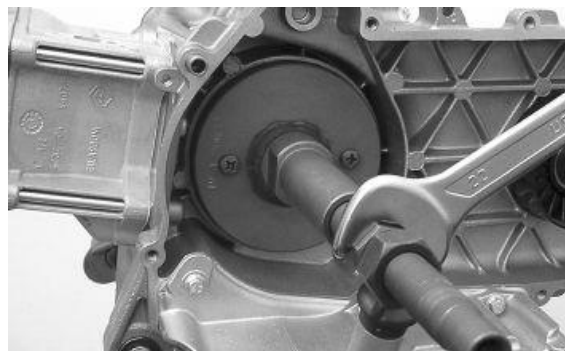
Specific tooling**020622Y Transmission-side oil seal punch**

Refitting

- Always use a new oil seal upon refitting
- Prepare the new oil seal by lubricating the sealing lip
- Pre-assemble the oil seal with the appropriate tool by positioning the screws.
- Insert the sheath over the crankshaft
- Insert the tool with the oil seal on the crankshaft until it comes into contact with the crankcase
- Insert the adaptor bushing of the tool in the hole on the crankcase.
- Orientate the oil seal by inserting the bracket which is part of the appropriate tool
- Tighten the threaded bar onto the crankshaft as far as it will go
- Use the nut to move the base of the tool until you can see the end of the oil seal driving stroke
- Remove all the tool components following the procedure but in reverse order.

CAUTION

DO NOT LUBRICATE THE KEYING SURFACE ONTO THE ENGINE CRANKCASE

CAUTION

ORIENT THE OIL SEAL BY POSITIONING THE CHAIN HOUSING CHANNEL FACING DOWNWARDS. WHEN THE POSITION IS REACHED, DO NOT RETRACT THE OIL SEAL. FAILURE TO COMPLY WITH THIS RULE CAN CAUSE A WRONG POSITIONING OF THE OIL SEAL SHEATH

CAUTION

FAILURE TO COMPLY WITH THIS ASSEMBLY PROCEDURE CAN SERIOUSLY DAMAGE THE ENGINE DUE TO THE WRONG TENSIONING OF THE OIL PUMP CONTROL CHAIN

Specific tooling

020622Y Transmission-side oil seal punch

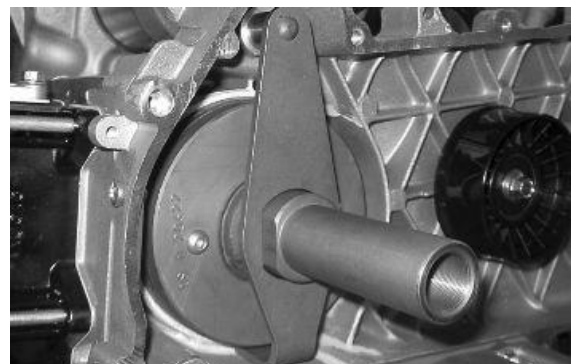
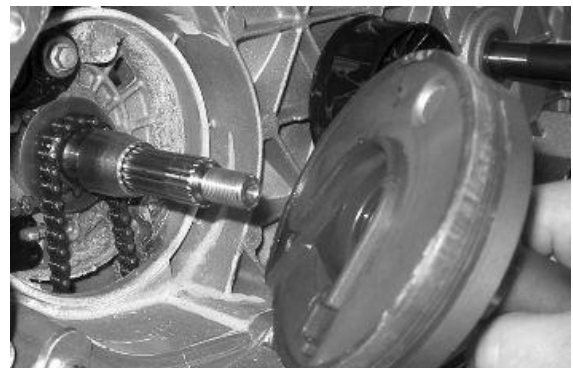
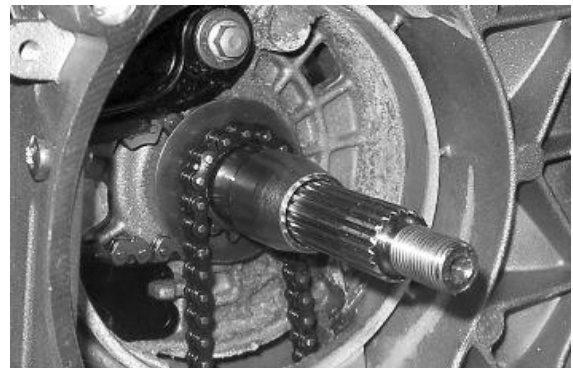

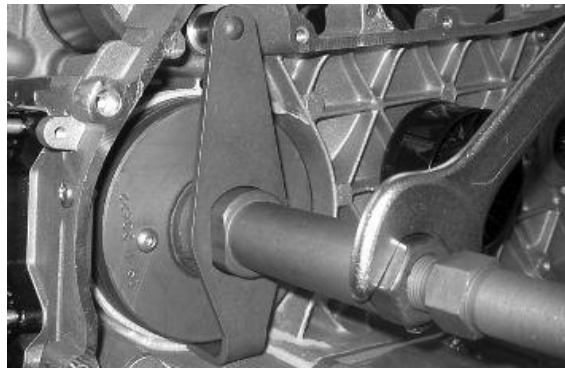

Oil pump

Removal

- Undo the two clamping screws in the figure and remove the cover over the pump control sprocket.

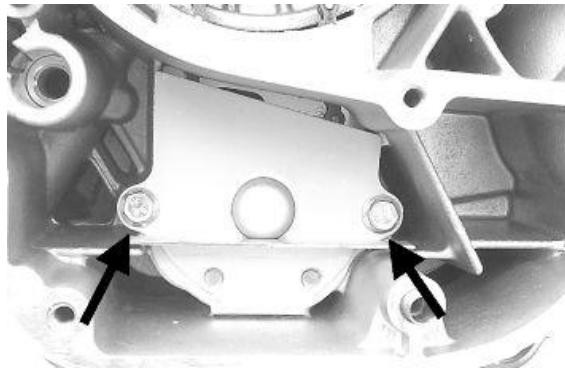

- Block the rotation of the oil pump driving pulley by inserting a screwdriver through one of its holes
- Remove the central screw with cup washer, as shown in the diagram.
- Remove the chain with the sprocket.
- Remove the control sprocket wheel and its O-ring.
- Remove the oil pump by undoing the two screws in the figure.
- Remove the oil pump seal.

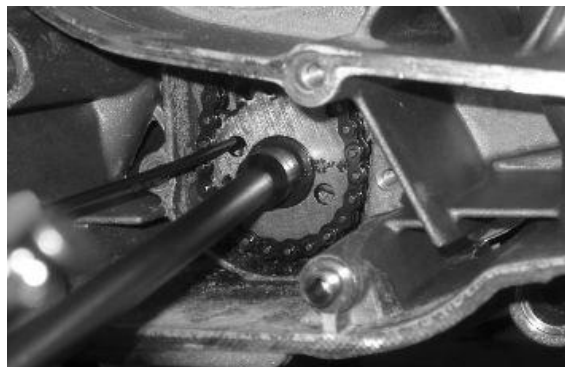

N.B.

IT IS ADVISABLE TO MARK THE CHAIN IN ORDER TO ENSURE THAT THE INITIAL DIRECTION OF ROTATION IS MAINTAINED

Inspection

- Remove the two screws and the oil pump cover.
- Remove the cir-clip retaining the innermost rotor.
- Remove and wash the rotors thoroughly with petrol and compressed air.
- Reassemble the rotors in the pump body, keeping the two reference marks visible. Replace the retainer ring.
- Check the clearance between the rotors in the position shown in the diagram using a feeler gauge. Measure the distance between the outer rotor and the pump body (see figure).
- Check the axial clearance of the rotors using a trued bar as shown in the figure.

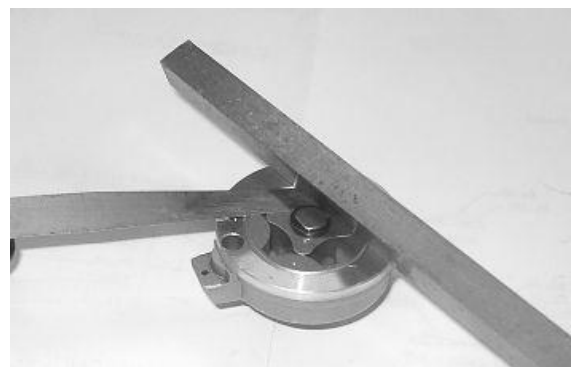
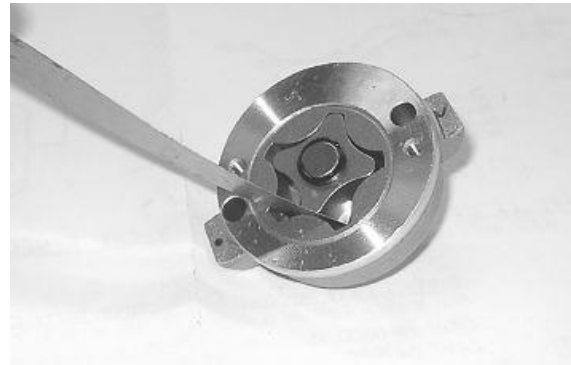

Refitting

- Check there are no signs of wear on the oil pump shaft or body.
- Check there are no signs of scoring or wear on the oil pump cover.
- If you detect non-conforming measurements or scoring, replace the faulty parts or the unit.
- Fit the pump cover in the position that permits the crankcase clamping screws to be aligned.
- Make sure the gasket is positioned properly and refit the pump on the engine crankcase. The pump can only be fitted in one position. - Tighten the screws to the prescribed torque.
- Fit the sprocket wheel with a new O-ring.
- Fit the chain.
- Fit the central screw and the cup washer. Tighten to the prescribed torque.
- Fit the oil pump cover, by tightening the two screws to the prescribed torque.

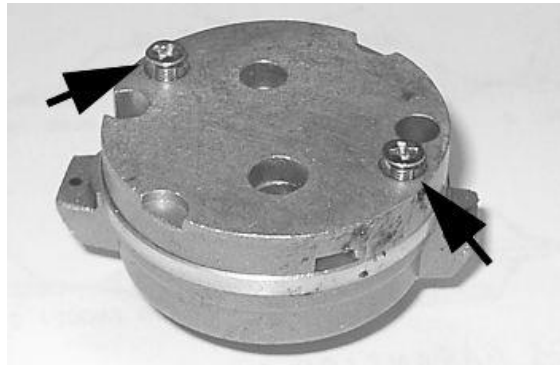

N.B.

FIT THE BELLEVILLE WASHER SO THAT ITS OUTER RIM TOUCHES THE PULLEY. MAKE SURE THAT THE PUMP TURNS FREELY.

Locking torques (N*m)

**Screws fixing oil pump to the crankcase 5 to 6
Oil pump command sprocket screw 10 - 14
Oil pump cover screws 0.7 - 0.9**

Removing the oil sump

To remove the oil sump, proceed as follows:

- Drain all the engine oil.
- Remove the transmission cover.
- Unscrew and remove the fixing screws.



- Remove the oil sump.



- Remove the valve spring.



- Remove the valve piston.



- Remove the oil sump gasket.

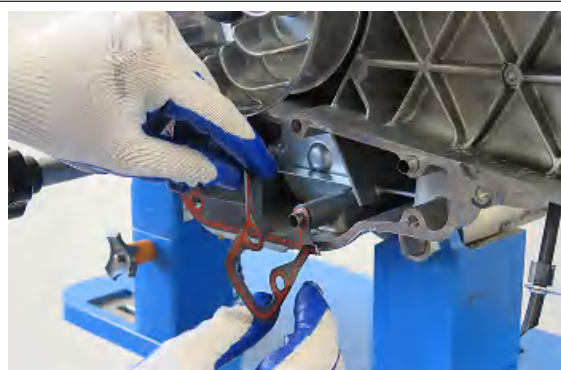

Inspecting the by-pass valve

- Check the unloaded spring length.
- Check that the small piston is not scored.
- Ensure that it slides freely on the crankcase and that it guarantees a good seal.
- If not, eliminate any impurities or replace defective parts.

Characteristic

By-pass check up: Standard length

54.2 mm

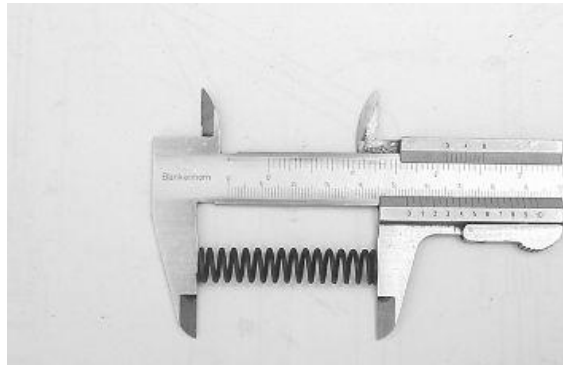

Refitting the oil sump

- Fit a new oil sump gasket.

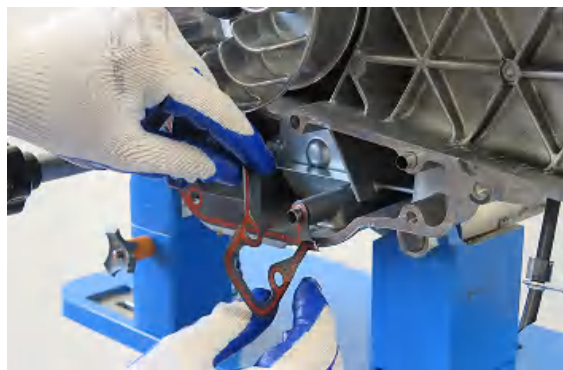

- Insert the valve piston.



- Insert the valve spring.



- Insert the alignment dowels.
- Insert the oil sump taking care to insert the spring into the appendage in the sump.



- Insert and tighten the fixing screws, applying the recommended torque.
- Refit the transmission cover.

Locking torques (N*m)

Oil sump - Crankcase 12.0 ± 1.0 Nm



INDEX OF TOPICS

INJECTION

INJEC

MIU injection system

This vehicle is fitted with an integrated injection and ignition system.

Injection is indirect in the manifold through an electro-injector.

The injection and ignition are timed on the four-stroke cycle by means of a tone wheel keyed on to the crankshaft (24-2 teeth) and pick-up sensor.

Mixture and ignition are managed on the basis of engine revs and throttle valve opening. Further corrections are made according to the following parameters:

- Coolant temperature
- Intake air temperature
- Lambda probe

The system implements cold engine idle fuel/air mixture correction with a stepper motor on a by-pass circuit of the throttle valve. The control unit manages the Stepper motor and the injector opening time, thereby ensuring the idle steadiness and the proper mixture.

In all conditions of use, mixture preparation is managed by modifying the injector opening time.

The fuel system pressure is kept constant in relation to ambient pressure.

The **fuel system circuit** consists of:

- Fuel pump
- Fuel filter
- Injector
- Pressure regulator

The pump, the filter and the regulator are placed inside the fuel tank on a single support.

The injector is connected by a pipe with fast-release fittings. The pressure regulator is located at the beginning of the circuit.

The fuel pump is controlled by the MIU control unit; this ensures safety of the vehicle.

The **ignition circuit** consists of:

- H.V. coil
- H.V. cable.
- Shielded cap
- MIU control unit
- Spark plug

The MIU control unit manages ignition with the best advance ensuring four-stroke timing (ignition only in the compression phase) at the same time.

The MIU injection-ignition system controls engine functions by means of a pre-set program.

Should any input signals fail, an acceptable working order of the engine is ensured to allow the user to reach a service station.

Of course, this cannot happen when the rpm-timing signal is missing, or when the failure involves the control circuits:

- Fuel pump

- H.V. coil
- Injector

The control unit is fitted with a self-diagnosis system connected to a warning light on the instrument panel.

Failures are detected and restored by the diagnostic tester.

In any case, when the fault is no longer present, data storage is automatically wiped clean after 16 cycles of use (cold starting, running at regular engine temperature, stop).

The diagnostic tester is also required to adjust the idle mixture.

Specific tooling

020922Y Diagnosis Tool

The MIU injection-ignition system carries out checks on the rpm indicator and the electric fan for radiator cooling.

The MIU control unit has a decoder for the anti-theft immobilizer system.

The MIU control unit is connected to a diagnostic LED on the instrument panel, that also carries out the deterrent flashing functions.

The MIU control unit power supply is furthermore controlled by the emergency switch; that is to provide further safety for the vehicle.

Precautions

1. Before repairing any part of the injection system, check if any faults have been stored. Do not disconnect the battery before checking for faults.
2. The fuel supply system is pressurised at 300 kPa (3 BAR). Before disconnecting the fast-release fitting of the fuel supply pipe, check that there are no naked flames. Do not smoke. Act with caution to avoid spraying fuel to your eyes.
3. When repairing electric components, the battery must always be disconnected unless it is strictly necessary for the battery to be connected.
4. When functional checks are performed, make sure that the battery voltage exceeds 12V.
5. Before attempting to start the vehicle, ensure that there are at least two litres of fuel in the tank. Failure to respect this norm will damage the fuel pump.
6. If a long period is envisaged with the vehicle not in use, fill the tank to at least the halfway mark. This will ensure the pump will be covered by fuel.
7. When washing the vehicle, do not spray excessive water on electric components and wiring harnesses.
8. In the event of ignition problems, begin troubleshooting from the battery and the injection system connections.
9. Before disconnecting the MIU control unit connector, perform the following steps in the order shown:
 - Set the switch to «OFF»

- Disconnect the battery

Failure to respect this norm may damage the control unit.

10. Do not invert the poles when fitting the battery.

11. In order to not cause damage, disconnect and reconnect the connectors of the MIU system only after proven necessary. Before reconnecting, check that the connectors are dry.

12. When carrying out electric inspections, do not force the tester probes into the connectors. Do not take measurements not specifically foreseen by the manual.

13. At the end of every check performed with the diagnostic tester, remember to protect the system connector with its cap. Failure to observe this precaution may damage the MIU control unit.

14. Before reconnecting the quick couplers of the power supply system, check that the terminals are perfectly clean.

Troubleshooting tips

1 A MIU failure is more likely to be due to the connections than to the components.

Before troubleshooting the MIU system, carry out the following checks:

A: Power supply

- a. Battery voltage
- b. Blown fuse
- c. Relays
- d. Connectors

B: Frame ground connection

C: Fuel system

- a. Faulty fuel pump
- b. Dirty fuel filter

D: Ignition system

- a. Faulty spark plug
- b. Faulty coil
- c. Faulty shielded cap

E: Intake circuit

- a. Air filter dirty
- b. Dirty by-pass circuit
- c. Faulty stepper motor

F: Others

- a. Wrong timing system
- b. Wrong idle mixture
- c. Incorrect reset of the throttle valve position sensor

2 MIU system failure may be caused by loose connectors. Make sure that all connections have been correctly made.

Check the connectors taking into consideration the following point:

A check that the terminals are not bent.

B check that the connectors have been properly connected.

C - Check whether the malfunction can be fixed by shaking the connector slightly.

3 Check the entire system before replacing the MIU. If the fault is fixed by replacing the MIU control unit, install the original control unit again and check if the fault occurs again.

4 For troubleshooting, use a multimeter with an internal resistance of more than 10 KW/V. Unsuitable instruments can damage the MIU ECU. The instruments to be preferred have a definition over 0.1V and 0.5W and an accuracy over 2%.

Terminals setup

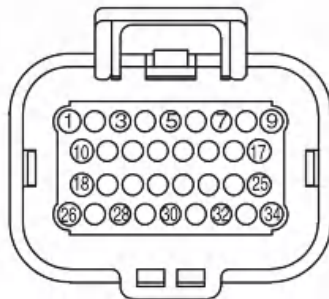

MIUG4 control unit

1. (Pink/Black) H.V. coil signal output (-)
2. Not connected
3. (Blue/Brown) ASR warning light command signal output
4. (Green/Black) Signal input (-) from engine stop button
5. (Brown/Red) Signal input (+) from the start button
6. (Red/White) Key-on power input (from fuse F4)
7. (Black) Power ground
8. Not connected
9. (White/Black) Battery power input (from fuse F1)
10. (Orange/Blue) Starter relay coil command signal output (-)
11. (Light blue/Black) Lambda probe (+)
12. (White/Green) Lambda probe (-)
13. (Light blue/Green) Engine temperature sensor signal input
14. (Orange/White) "ENABLE" signal input from the immobilizer antenna
15. (Grey/Green) Sensor ground reference
16. Not connected
17. (Red/Green) Immobilizer warning light control signal output (-)
18. (Grey/Black) Tilting sensor signal input
19. (Brown/Red) Signal input (-) from the stand button
20. (Brown) Pickup (-)

- 21. (Light blue/White) Signal input (-) from the ASR button
- 22. (Black/Purple) Injection loads coil command signal output (-)
- 23. (Black) Power ground
- 24. (Blue/Yellow) Electric fan relay coil command signal output (-)
- 25. (Brown/Black) MIL warning light control signal output (-)
- 26. (Pink/Red) CAN H line
- 27. (Pink/White) CAN L Line
- 28. Not connected
- 29. (Red) Pickup (+)
- 30. Not connected
- 31. (Light blue/red) Ground reference for lambda probe heater
- 32. Not connected
- 33. (Purple/White) Lights relay coil command signal output (-)
- 34. (Red/Yellow) Injector command signal output (-)

Troubleshooting procedure

Engine does not start

ENGINE DOES NOT START EVEN IF PULLED

Possible Cause	Operation
Immobilizer enabling signal	System not encoded System not efficient, repair according to the indications of the self-diagnosis
Faults detected by self-diagnosis	Pump relay H.V. coil Injector Engine speed timing sensor
Fuel system	Fuel in the tank Fuel pump activation Fuel pressure (low) Injector flow (low)
Power to spark plug	Shielded spark plug cap H.V. coil (secondary insulation)
Parameter reliability	Coolant temperature Distribution timing adjustment - injection start Intake air temperature
End of compression pressure	End of compression pressure

Starting difficulties

ENGINE STARTER PROBLEMS

Possible Cause	Operation
Faults detected by self-diagnosis	Pump relay H.V. coil Injector Engine speed timing sensor Air temperature Coolant temperature
Starter speed	Starter motor and relay Battery

Possible Cause	Operation
End of compression pressure Power to spark plug	Ground connections End of compression pressure Spark plug Shielded cap H.V. coil Engine speed timing sensor Ignition advance
Fuel system	Fuel pressure (low) Injector flow (low) Injector sealing (poor)
Correctness of the parameters	Coolant temperature Intake air temperature Stepper throttle valve position (steps and actual opening) Cleaning of the auxiliary air pipe and throttle valve; air filter efficiency

Engine stops at idle

ENGINE DOES NOT IDLE/ IDLING IS UNSTABLE/ IDLING TOO LOW

Possible Cause	Operation
Faults detected by self-diagnosis	Pump relay H.V. coil Injector Engine speed timing sensor Air temperature Coolant temperature
Ignition efficiency	Spark plug Ignition timing
Correctness of the parameters	Throttle valve position sensor Stepper Coolant temperature sensor Intake air temperature sensor
Intake system cleaning	Air filter Diffuser and throttle valve Additional air pipe and Stepper
Intake system sealing (infiltrations)	Intake manifold - head Throttle body - manifold Intake sleeve Filter housing
Fuel system (low pressure)	Fuel pump Pressure regulator Fuel filter Injector flow

Engine does not rev down

ENGINE DOES NOT RETURN TO IDLING SPEED/IDLING SPEED TOO HIGH

Possible Cause	Operation
Faults detected by self-diagnosis	Pump relay H.V. coil Injector Engine speed timing sensor Air temperature Coolant temperature
Ignition efficiency	Ignition timing
Correctness of the parameters	Throttle valve position sensor Stepper Coolant temperature sensor Intake air temperature sensor
Intake system sealing (infiltrations)	Intake manifold - head Throttle body - manifold Intake sleeve Filter housing

Possible Cause	Operation
Fuel system (low pressure)	Fuel pump Pressure regulator Fuel filter Injector flow

Exhaust backfires in deceleration

EXHAUST BACKFIRING WHEN DECELERATING

Possible Cause	Operation
Faults detected by self-diagnosis	Pump relay H.V. coil Injector Engine speed timing sensor Air temperature Coolant temperature Lambda probe
Correctness of the parameters	Throttle valve position sensor Stepper Coolant temperature sensor Intake air temperature sensor
Intake system sealing (infiltrations)	Intake manifold - head Throttle body - manifold Intake sleeve Filter housing
Fuel system (low pressure)	Fuel pump Pressure regulator Fuel filter Injector flow
Exhaust system sealing (infiltrations)	Manifold - head Manifold - silencer silencer welding

Engine revs irregularly

ENGINE IRREGULAR PERFORMANCE WITH VALVE SLIGHTLY OPEN

Possible Cause	Operation
Intake system cleaning	Air filter Diffuser and throttle valve Additional air pipe and Stepper
Intake system sealing	Intake sleeve Filter housing
Ignition system Parameter reliability	Spark plug wear check Throttle valve position signal Coolant temperature indicator Intake air temperature signal Ignition advance
TPS reset successful Faults detected by self-diagnosis	TPS reset successful Pump relay H.V. coil Injector Engine speed timing sensor Air temperature Coolant temperature Lambda probe

Poor performance at full throttle

POOR ENGINE PERFORMANCE AT FULL POWER/ ENGINE IRREGULAR PERFORMANCE ON PICK-UP

Possible Cause	Operation
Faults detected by self-diagnosis	Pump relay H.V. coil Injector Engine speed timing sensor Air temperature Coolant temperature Lambda probe
Power to spark plug	Spark plug Shielded cap H.V. cable H.V. coil
Intake system	Air filter Filter box (sealing) Intake sleeve (sealing)
Parameter reliability	Throttle valve position signal Coolant temperature indicator Intake air temperature signal Ignition advance
Fuel system	Fuel level in the tank Fuel pressure Fuel filter Injector flow

Engine knocking

PRESENCE OF KNOCKING (COMBUSTION SHOCKS)

Possible Cause	Operation
Faults detected by self-diagnosis	Pump relay H.V. coil Injector Engine speed timing sensor Air temperature Coolant temperature Lambda probe
Ignition efficiency	Spark plug
Parameter reliability	Throttle valve position signal Coolant temperature indicator Intake air temperature signal Ignition advance
Intake system sealing	Intake sleeve Filter housing
TPS reset successful	TPS reset successful
Fuel system	Fuel pressure Fuel filter Injector flow Fuel quality
Selection of the cylinder base gasket thickness	Selection of the cylinder base gasket thickness

Fuel supply system

The fuel supply circuit includes the electric pump, the filter, the pressure regulator, the electro-injector and the fuel delivery pipes.

The electrical pump is located in the tank from which the fuel is pumped and sent to the injector through the filter.

The pressure is controlled by the pressure regulator situated in the pump assembly in the tank.

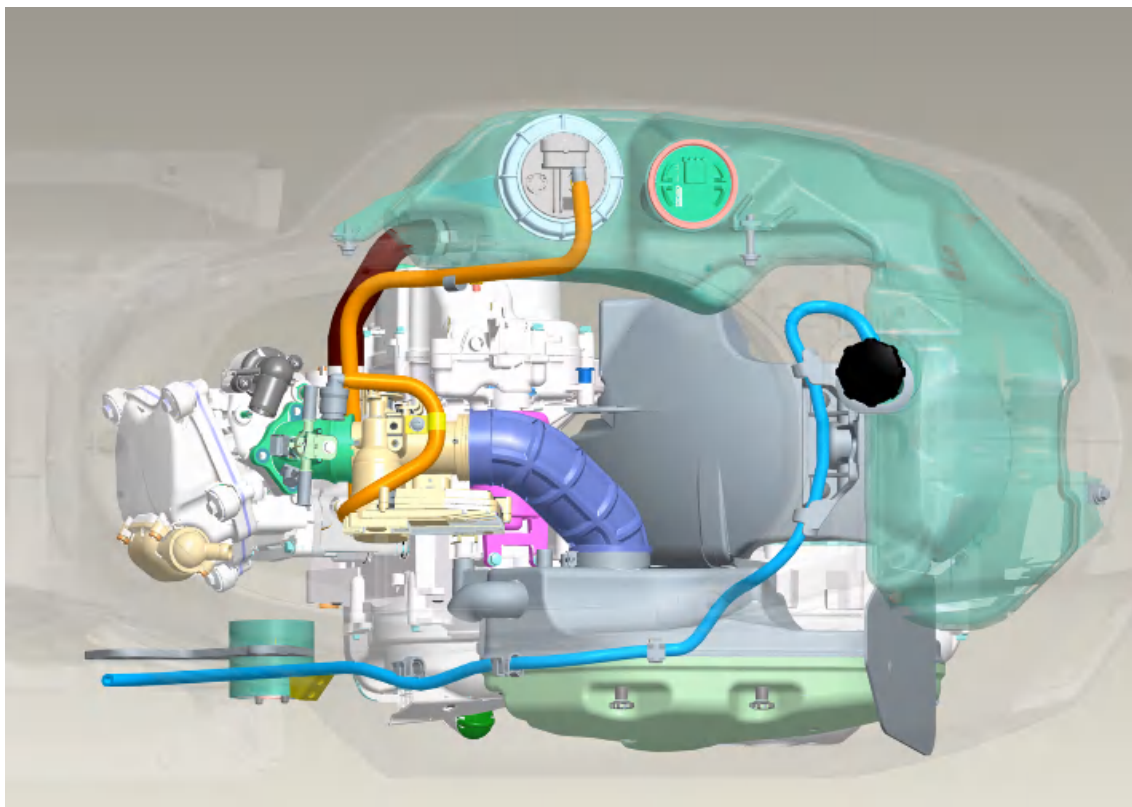

Removing the butterfly valve

To remove the throttle body, proceed as follows:

- Unscrew and remove the fuel pipe clamp fastening screw.

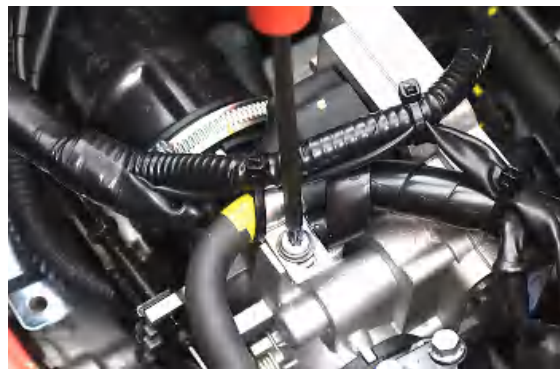

- Disconnect the injector connector.



-
- Disconnect the engine temperature sensor connector.



-
- Loosen the clamps of the intake manifold and of the filter box connection sleeve.



-
- Disconnect the connector of the control unit.



-
- Loosen the fixing nuts of the throttle control transmissions.



-
- Disconnect the throttle control cables.



-
- Remove the throttle body.



Refitting the butterfly valve

-
- put the throttle body.



-
- Connect the throttle control cables.



- Tighten the fixing nuts of the throttle control transmissions.

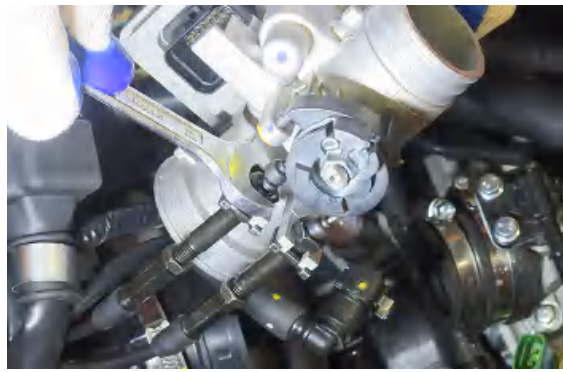

- Put the throttle body in the intake manifold and in the connection pipe to the filter box.
- Tighten the clamps.



- Connect the control unit connector.



- Connect the engine temperature sensor connector.



- Connect the injector connector.

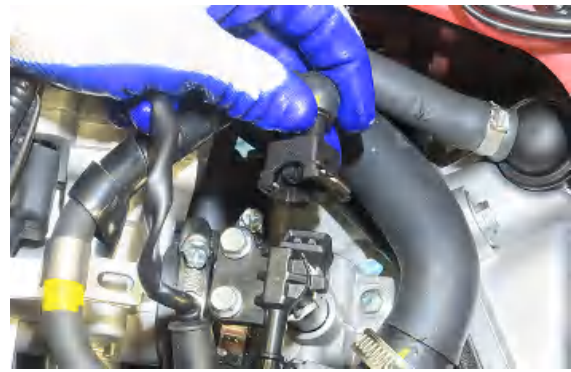

- Insert and tighten the screw that fastens the fuel pipe clamp.

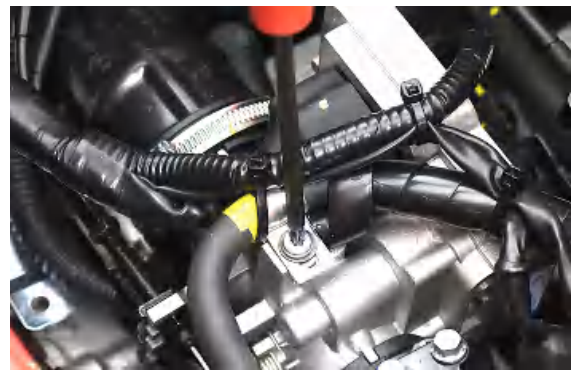

predelivery ASR SYSTEM calibration/ ECU replacement

In case of predelivery vehicle, or following the replacement of the engine management control unit, **on which the ASR system initialisation procedure has never been performed**, proceed as follows.

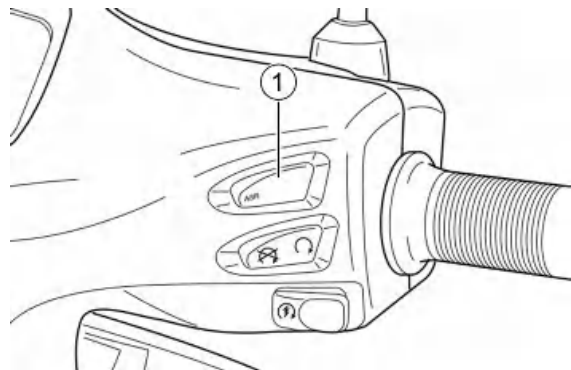

After key "**ON**", the ABS indicator light flashes and the ASR icon "**2**" is **switched on steady**.

1. Start the vehicle and ride a short distance of more than 5 km/h (3 mph) and wait for the flashing of the ASR warning light to stop. The ASR icon stays switched on steady.

2. Stop the vehicle and leave the engine running at idle speed for at least 3 seconds.

3. Press the engine start button and the ASR on/off button "**1**" simultaneously for at least 4 seconds (**pulling the left brake lever has no effect**).

4. The activation of the procedure will be confirmed by the slow flashing switched on ASR icon "**2**" (1 flash every 2 seconds).



5. Accelerate to a constant speed of 30 km/h (18.7 mph) and maintain it for at least to 10 seconds.
6. The end of the procedure will be indicated by turning off the ASR icon "2".
7. Once the procedure is completed, turn the ignition switch to "OFF" and wait at least 30 seconds for the next key "ON".
8. In case of failure to complete the procedure within 2 minutes the ASR icon "2" will stay on steady and the ASR will remain disabled until the next key "OFF".
9. To restart the ASR, it is necessary to turn the key to "ON", and repeat the procedure until achieving positive result.



Pump supply circuit

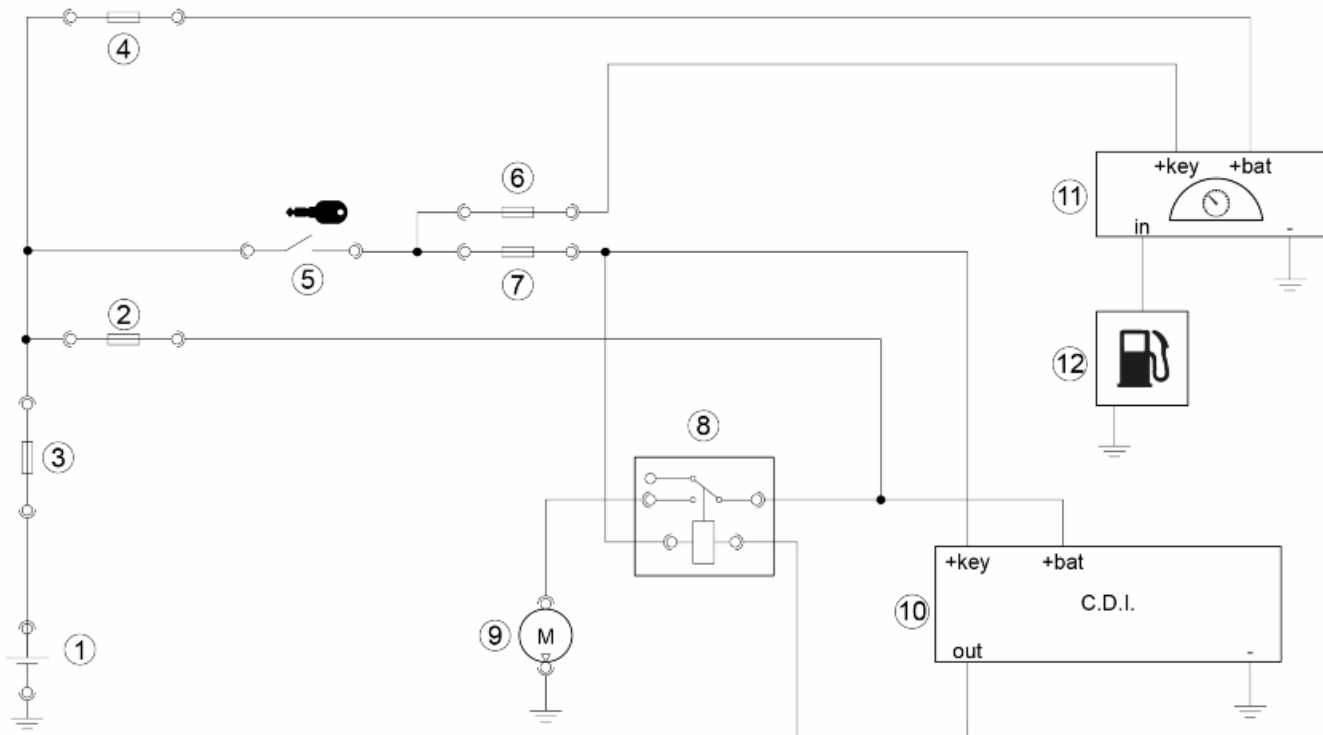

1. Battery 12V
2. Fuse no.7 - 10A

3. Fuse no.1 - 30A
4. Fuse No. 5; 15A
5. Ignition switch
6. Fuse no.2 - 7.5A
7. Fuse no.4 - 7.5A
8. Injection load relay
9. Fuel pump
10. Electronic injection control unit
11. Instrument panel
12. Fuel level indicator

When switched to "ON", the fuel pump starts to rotate for two seconds and then stops. When the engine starts, in the presence of rpm timing signal the pump is continuously supplied.

ELECTRICAL DATA

- Pump winding resistance ~ 1.5 Ohm
- Input current during regular operation 1.4 - 1.8 A
- Input current to the closed hydraulic circuit ~ 2 A (to be checked with specific tool for fuel pressure control, choking the circuit on the return pipe)

1. Disconnect the fuel pump electrical connector.
2. Turn the ignition switch to «ON».
3. Check that there is a voltage present between pin 2 and ground on the fuel pump connector for approximately 2 seconds.
4. Carry out a continuity check on the connection line between pin 2 on the fuel pump connector and pin 87 on the injection loads relay.
5. Carry out a continuity check on the connection line between pin 1 on the fuel pump connector and ground

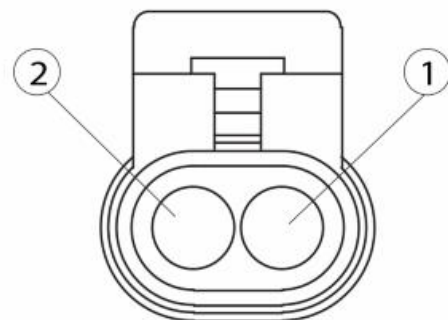

Circuit leak test

Install the specific tool for checking the fuel pressure, with the pipe fitted with the gauge.

Check during regular operation by placing the appropriate tool between the pump and the injector. With the battery voltage > 12 V check that the fuel pressure is 3.0 BAR and that the input current is 1.4 to 1.8 A



With the battery voltage > 12 V, check the pump flow rate by disconnecting from the injector the pipe equipped with the pressure gauge of the appropriate tool. Prepare a graded burette with flow rate of approximately 1 L. Rotate the pump using the active diagnosis of the palm top computer. Using a pair of long flat needle-nose pliers, choke the fuel pipe making the pressure stabilise at approx. 3.0 BAR. Check that within 15 seconds the pump has a flow rate of approx. 120 cm³.

Specific tooling

020480Y Fuel pressure measurement kit

Fuel filter check

Disconnect the terminals of the electrical pump

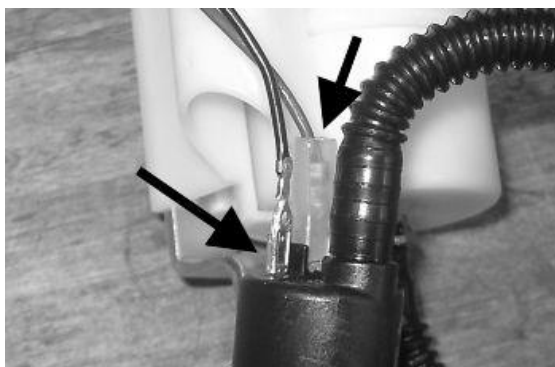

Remove the screw shown in the picture

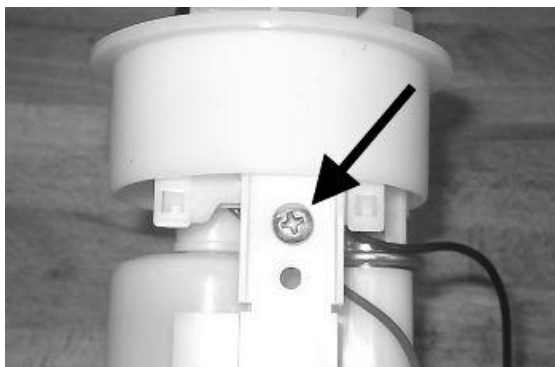

Remove the clamp fixing the piping to the filter shown in the photograph



Separate the lower part of the pump mounting as shown in the picture.

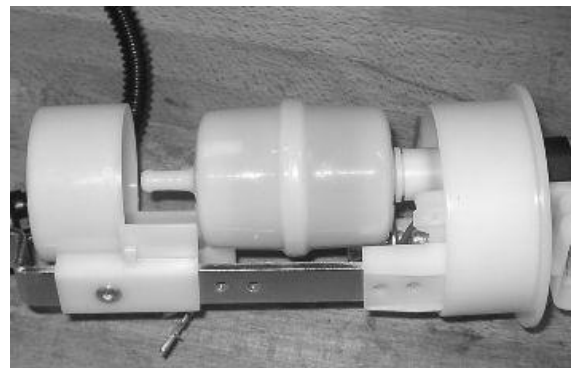

Remove the filter from the pump mounting



Inspecting the injector circuit

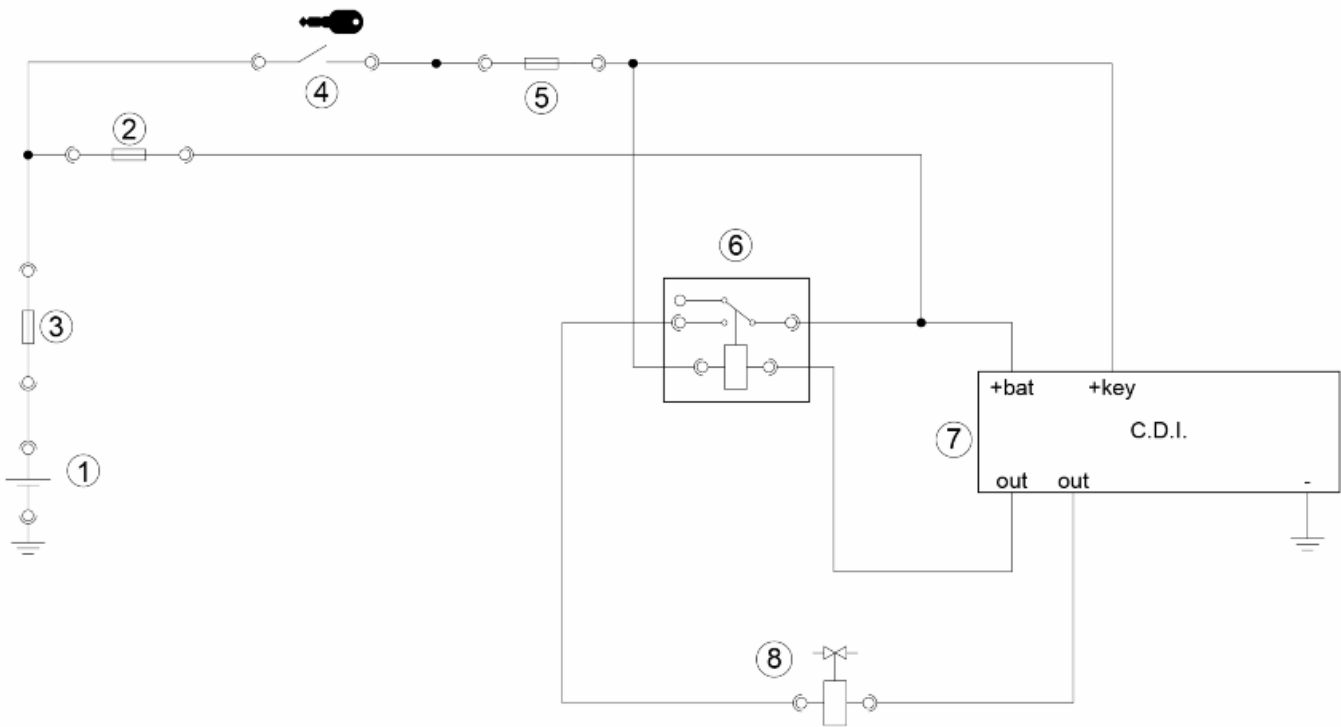

1. Battery
2. Fuse n° 7 -10A
3. Fuse no.1 - 30A
4. Ignition switch
5. Fuse no.4 - 7.5A
6. Injection load relay
7. Electronic injection control unit
8. Injector

Checking the resistance at the injector ends: $14.5 \pm 5\%$ Ohm

With the control unit and the injector disconnected, check for continuity between pin 34 on the control unit connector and pin 2 on the injector connector.

Switch to «**ON**» and check that, with the injector disconnected and the control unit connected, there is a voltage present between pin 1 on the injector connector and ground.

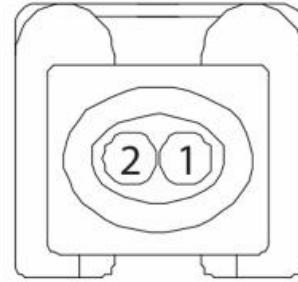

Inspecting the injector hydraulics

To check the injector, proceed as follows:

- Unscrew and remove the screws that fasten the injector to the intake manifold.



- Remove the injector from the intake manifold.



- Install the specific tool to check the fuel pressure and put the manifold on a graduated container of at least 100 cm³.

- Connect the injector with the supplied cable for the injection tester.

- Connect the cable terminals to an auxiliary battery and activate the fuel pump with the diagnostics active.



Specific tooling

020480Y Fuel pressure measurement kit

- Check that within 15 approx. 44 cm³ of fuel is delivered with an adjustment pressure of approx. 3 BAR.



Proceed with the injector seal test.

Dry the injector outlet with a blast of compressed air. Activate the fuel pump. Wait for one minute, making sure there are no leaks coming from the injector. Slight oozing is normal.

Value limit = 1 drop per minute



HT coil

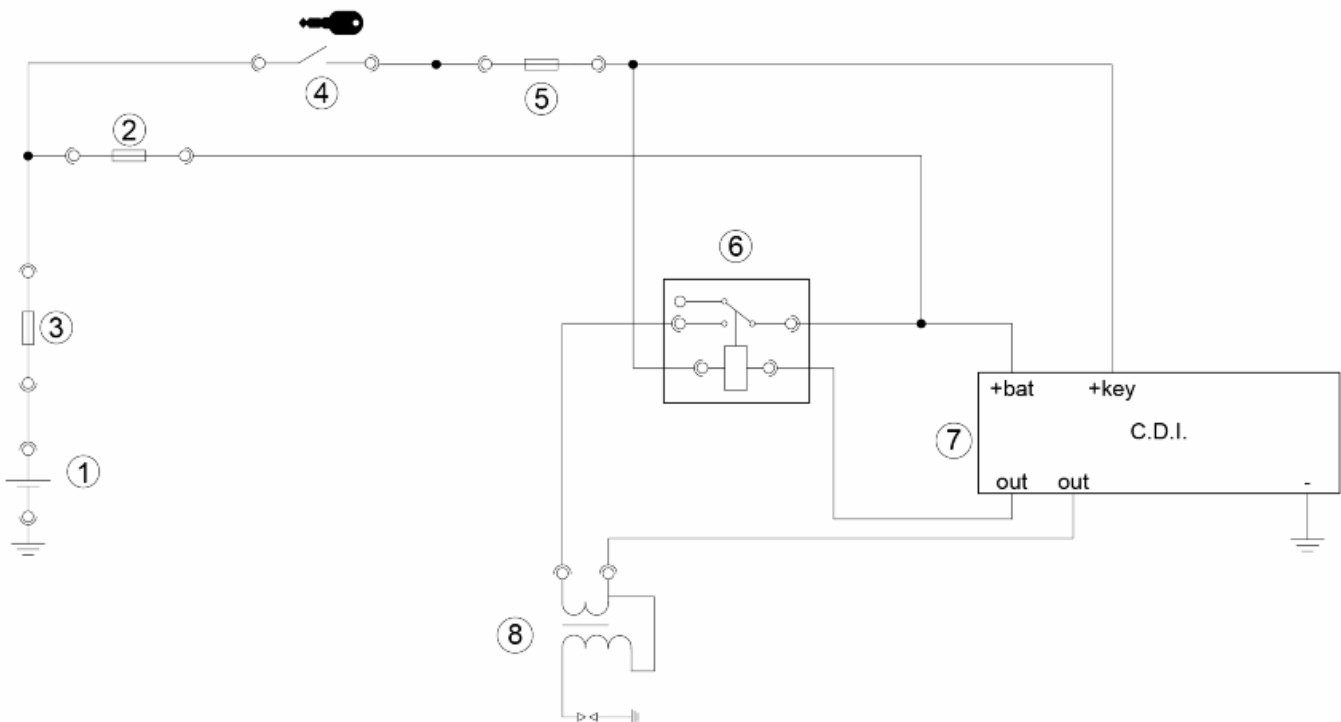

1. Battery
2. Fuse n° 7 -10A

3. Fuse no.1 - 30A
4. Ignition switch
5. Fuse no.4 - 7.5A
6. Injection load relay
7. Electronic injection control unit
8. H.V. coil

The system is integrated with the injection and it is a high-efficiency inductive type ignition.

The control unit manages two significant parameters:

- Ignition advance

This is optimised at once according to the engine revs, engine load, temperature and ambient pressure.

- Magnetisation time

The coil magnetisation time is controlled by the control unit. The ignition power is increased during the engine start-up phase.

The injection system recognises the 4-stroke cycle so ignition is only commanded in the compression phase.

Specific tooling

020331Y Digital multimeter

With the control unit and the coil disconnected, check for continuity between pin 1 on the control unit connector and pin 2 on the coil connector.

Switch to «ON» and check that, with the coil disconnected and the control unit connected, there is a voltage present between pin 1 on the coil connector and ground.

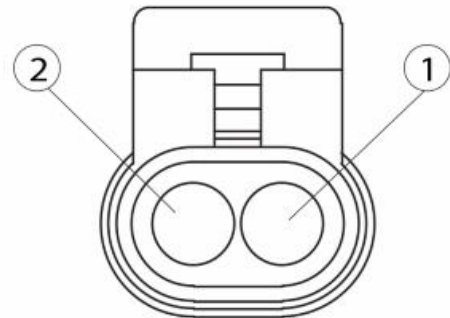

Zeroing the throttle

Resetting the throttle valve position signal (T.P.S reset)

The MIU control unit is supplied with a throttle valve position sensor that is pre-calibrated.

Pre-calibration entails regulating the minimum opening of the throttle valve to obtain a certain flow of air under pre-set reference conditions.

Pre-calibration ensures optimal air flow to control idling.

This regulation must not be tampered with in any way whatsoever.

The injection system will complete the management of the idling through the Stepper motor and the variation of the ignition advance.

The throttle body after the pre-calibration has an opened valve with an angle that can vary depending on the tolerances of the machining of the pipe and the valve itself.

The valve position sensor can also assume various fitting positions. For these reasons the mV of the sensor with the valve at idle can vary from one throttle body to another.

To obtain the optimum fuel mixture, especially at small openings of the throttle valve, it is essential to match the throttle body with the control unit following the procedure known as TPS resetting.

With this operation we inform the control unit, as the starting point, of the mV value corresponding to the pre-calibrated position.

To reset, proceed as follows.

Connect the diagnostic tester.

Switch to «ON».

Select the functions of the diagnostic tester on «TPS RESET».

Specific tooling

020922Y Diagnosis Tool

Make sure that the throttle valve with the control is supporting the stop screw.

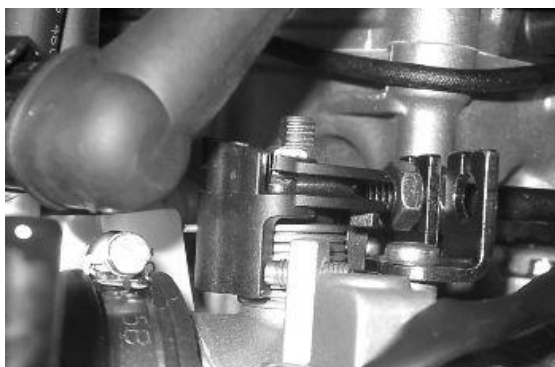

Guaranteeing that this position will be kept, send a confirmation for the TPS reset procedure.

Reset should be performed in the following cases:

- on first fitting.
- if the injection control unit is replaced.

N.B.

THE TPS RESET PROCEDURE MUST NOT BE CARRIED OUT WITH A USED THROTTLE BODY BECAUSE POSSIBLE VALVE WEAR AND STOP WEAR FOR THE MINIMUM OPENING MAKE THE AIR FLOW DIFFERENTLY FROM THAT OF PRE-CALIBRATION.

Given that the TPS resetting is also done when the control unit is replaced, place the control unit - filter box bellows at 45° during the refitting operation as shown in the picture.



INDEX OF TOPICS

SUSPENSIONS

SUSP

This section is dedicated to operations that can be carried out on the suspensions.

Front

STEERING ASSEMBLY

Name	Torque in Nm
Upper steering ring nut	35 - 40
Lower steering ring nut	12 - 14
Handlebar fixing screw	50 - 55
Fixing screws for the handlebar control unit U-bolts	7 - 10

FRONT SUSPENSION

Name	Torque in Nm
Screw fixing the shock absorber to the shock absorber - calliper attachment plate	20 to 27
Wheel axle nut	74 - 88
Wheel screw	20 - 25
Screw fixing rear mudguard to steering shock absorber upper clamp	5 - 6.5
	20 to 30

Removing the front wheel

- Rest the vehicle on its centre stand.
- Suitably secure the rear part of the vehicle by raising the front slightly.
- Loosen the screws fixing the wheel rim to the hub.



Remove the front wheel.



Front wheel hub overhaul

REMOVING THE FRONT WHEEL HUB

Rest the vehicle on its centre stand.

Suitably secure the rear part of the vehicle by raising the front slightly.

Remove the front wheel.

Remove the front brake calliper.

Remove the safety cotter pin bending the flaps.

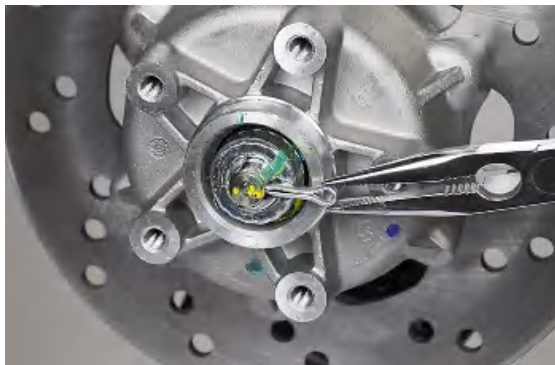

Remove the safety cap.



Unscrew the nut fixing the front wheel hub to the wheel axis.



Remove the nut.



Remove the front wheel hub from its seat.

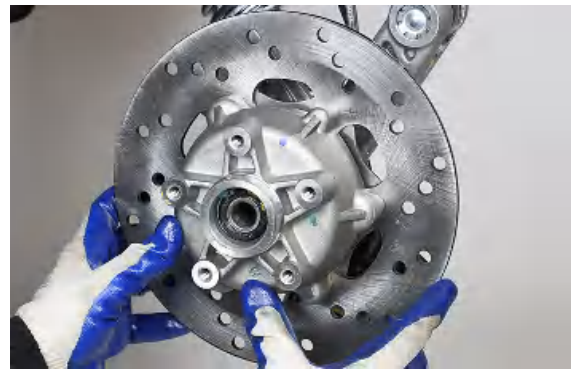

FRONT WHEEL HUB SERVICE

Remove the oil seal on the brake disc side using a flat-head screwdriver.



Turn the hub on the wheel side.

Using the relative clamps, remove the Seeger ring.



Engage the specific tool on the inner ring of the bearing on the wheel side.

Specific tooling

001467Y Extractor for bearings for holes



Remove the bearing using the specific tool.

Specific tooling

001467Y Extractor for bearings for holes

001467Y017 Bell Ø 35



Remove the bearing and the specific tool.



Remove the roller bearing using the specific tool.

Specific tooling

020376Y Adaptor handle

020456Y Ø 24 mm adaptor

020363Y 20-mm guide



Check the seat of the bearing.

Heat the bearing's seat on the hub using the specific tool.

Specific tooling

020151Y Air heater



Using the specific tool, place the new ball bearing in its seat with the shielding facing up.

Specific tooling

020376Y Adaptor handle

020357Y 32 x 35-mm Adaptor

020412Y 15-mm guide



Put the bearing all the way into its seat.



Put in the Seeger ring.



Turn the hub on the opposite side.

Using the specific tool, insert the roller bearing all the way in.

Apply the recommended product in the chamber between the ball bearing and the roller bearing.

Specific tooling

020038Y Punch

Recommended products

Lubricant grease Lithium and medium fibre yellow brown coloured grease suitable for various uses.

ISO L-X-BCHA 3 - DIN 51 825 K3K -20



Using the specific tool, put a new oil seal in its seat.

Specific tooling

020376Y Adaptor handle

020357Y 32 x 35-mm Adaptor

020412Y 15-mm guide



Put the oil seal all the way into its seat.



FITTING THE FRONT WHEEL HUB

Place the wheel hub on the front wheel axle.

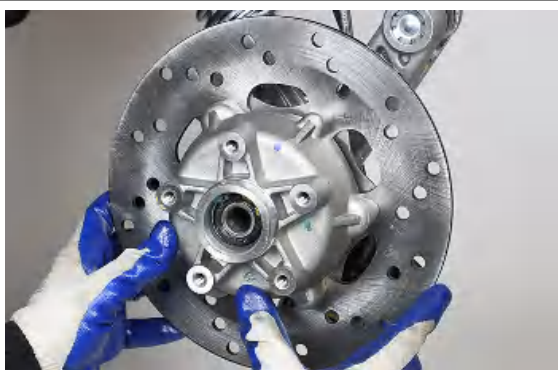

Screw on the fixing nut on the wheel axle.



Tighten the fixing nut on the wheel axle to the prescribed torque.

Locking torques (N*m)**Front wheel hub - Wheel axle 74 - 88 Nm**

Put on the safety cap so that the hole for the cotter pin is visible.



Insert the safety cotter pin and fold the flaps outwards.

Refit the front brake calliper.

Fit the front wheel.

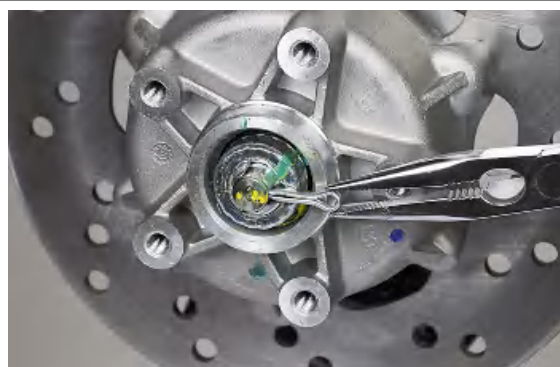

Refitting the front wheel

Put back the front wheel on the wheel hub.



Tighten to the recommended torque the screws fixing the front wheel to the hub.

Locking torques (N*m)

Rear wheel - Front wheel hub 19 - 24 Nm



Handlebar

Removal

Rest the vehicle on its centre stand.
Remove the rear-view mirrors.
Remove the front centre cover.
Remove the front handlebar cover.
Remove the rear handlebar cover.
Disconnect the stop light switch cables on both sides of the vehicle.



Unscrew the screws fixing the U-bolt of the rear brake pump.



Remove the rear brake pump without detaching the brake piping.



Unscrew the end fixing screw from both sides of the handlebar and remove it.



Using compressed air, remove the left knob from the handlebars.



Unscrew the screws fixing the U-bolt of the throttle and remove it.

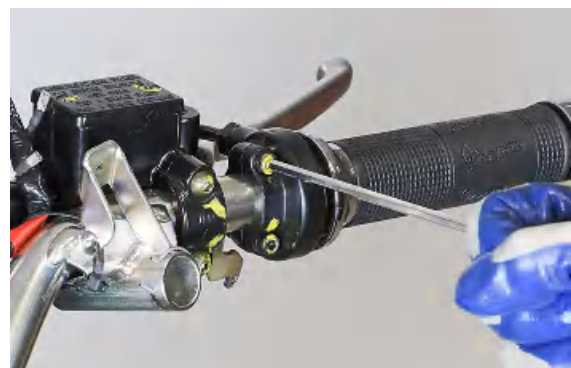

Release the throttle control transmissions from the sleeve.



Take out the entire throttle sleeve.



Unscrew the screws fixing the U-bolt of the front brake pump.



Remove the front brake pump from the handlebars without detaching the brake piping.



Remove the Velcro ties fixing the wiring harness onto the handlebars.



Unscrew the bolt fixing the handlebars to the steering tube and remove it.



Take the handlebars out of the steering tube.



Refitting

Reposition the handlebars on the steering tube.



Insert the bolt at the relative seat on the steering tube.



Tighten the bolt fixing the handlebars to the steering tube to the prescribed torque.

Locking torques (N*m)

Handlebars - Steering tube 50 - 55 Nm



Fix the wiring harness, on both sides of the handlebars, with a Velcro tie at the red marking on the wiring harness.



Place the front brake pump in its seat.



Tighten the screws fixing the U-bolt to the brake pump to the prescribed torque.

Locking torques (N*m)

Brake pump - Handlebars 7 - 10 Nm



Place the throttle sleeve on the handlebars.



Insert the throttle transmissions on the sleeve and reposition the fixing U-bolt.

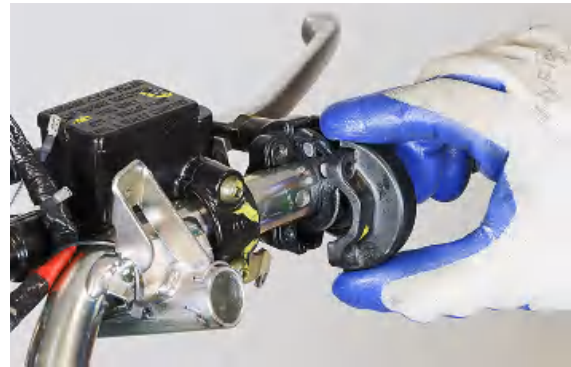

Tighten the screws fixing the U-bolt to the gas throttle to the prescribed torque.

Locking torques (N*m)

U-bolt - Throttle control sleeve 3 - 4 Nm



Using compressed air, reposition the left knob on the handlebars.



Working on both sides of the handlebars, tighten the screw fixing the handlebar end to the prescribed torque.

Locking torques (N*m)**Handlebar end - Handlebars 9 - 11 Nm**

Put back the rear brake pump on its seat on the handlebars.



Tighten the screws fixing the U-bolt to the brake pump to the prescribed torque.

Locking torques (N*m)**Brake pump - Handlebars 7 - 10 Nm**

Connect the stop light switch cables on both sides of the vehicle.

Refit the rear handlebar cover.

Refit the front handlebar cover.

Refit the front centre cover.

Refit the rear-view mirrors.

**Steering column**

Removal

Rest the vehicle on its centre stand.
Remove the rear-view mirrors.
Remove the front centre cover.
Remove the front handlebar cover.
Remove the rear handlebar cover.
Remove the handlebars
Remove the front wheel.
Remove the front brake calliper from the support without detaching the tubing.
Remove the front shock absorber.
Reposition the protective collar.



Release the retention clamp of the front brake piping and the wiring harness of the ABS sensor from the steering tube.



Working on the inside of the front mudguard, release the Velcro tie fixing the front brake piping and the ABS sensor wiring harness.



Using the specific tool, unscrew the upper ring nut fixing the steering tube to the headstock.

Specific tooling

020055Y Wrench for steering tube ring nut



Remove the upper ring nut.



Remove the safety plate



Using the specific tool, unscrew the lower ring nut fixing the steering tube to the headstock. Supporting the steering tube at the bottom.

Specific tooling

020055Y Wrench for steering tube ring nut



Remove the lower ring nut.



Remove the ball cage of the upper steering bearing.



Take out the steering tube from below so that you can access the screws fixing the front mudguard.



Unscrew the front mudguard fixing screws and definitively remove the steering tube from its seat.



Overhaul

Servicing the front suspension-steering assembly, described below, deals mainly with replacing parts (pin- NADELLA roller bushings - sealing rings unit and dust gaiter) which connect the steering tube to the front wheel holder swinging hub.

N.B.

BEFORE PROCEEDING WITH THE DESCRIBED SERVICE, CHECK THAT THE STEERING TUBE AND THE WHEEL HOLDER HUB ARE IN EXCELLENT CONDITIONS: ONLY THEN IS THE SERVICE JUSTIFIABLE.

MOREOVER, REMEMBER THE STEERING TUBE SHOULD BE REPLACED WITH A NEW ONE WHEN DEFORMED.

a = Ø 12 Punch

b = Sharp-edged end

Use a suitable punch with the dimensions indicated on the figure; hit with a mallet until the wedging washer is crushed and then extract it with the help of a pointed end.

Repeat the operation for the second washer using the punch on the side opposite to the one shown in the figure.

Use the tool fitted with part 1 as shown in the figure and move the tool hand-grip until the pin and the NADELLA are simultaneously ejected in the direction opposite the tool thrusting force.

After removing the pin and the first NADELLA, the swinging hub gets detached from the steering tube.

To remove the second NADELLA, use the tool fitted with part 2 instead of part 1, on the side opposite the one shown in the figure.

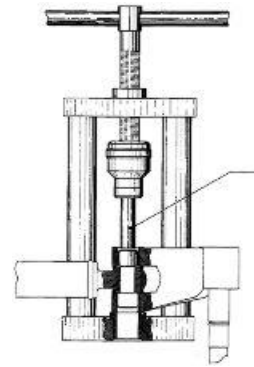

N.B.

DURING THE REMOVAL OPERATIONS DESCRIBED ABOVE, THE ROLLER BUSHINGS ARE DESTROYED WHEN THE EXTRACTOR IS USED. UPON REFITTING, IT IS THEREFORE NECESSARY TO USE NEW BUSHINGS AS WELL AS A NEW PIN, NEW SEALING RINGS AND DUST GAITER.

Specific tooling

020021Y Front suspension service tool

Connect the swinging hub to the steering tube with the guiding pin.

- Use the tool fitted with part 3 on the stem and part 4.

Lubricate the pin with recommended grease and insert it temporarily on the swinging hub, move the tool hand-grip until part 3 is fully inserted on the steering tube.

After fitting the pin, insert the two spacers, slightly hitting them with the mallet.

N.B.

BEFORE PROCEEDING WITH THE DESCRIBED FITTING, PLACE THE TWO DUST GAITER RINGS ON THE SWINGING HUB AS SHOWN IN THE FIGURE.

Specific tooling

020021Y Front suspension service tool

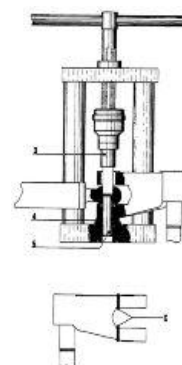

Recommended products

Molybdenum disulphide grease Lithium grease with molybdenum disulphide

Grey black grease.

Insert the sealing ring on the pin and the roller bushing with its wedging washer at the same time.

- Remove the tool and the part 5 (guide), which has been partially ejected during the previous pin fitting phase, and leave part 4 always fitted.
- Replace part 3 with part 16 (on the stem).
- By moving the tool hand-grip, push the wedging washer - roller bushing - seal ring unit, placing part 16 until it stops on the swinging hub.
- Repeat the above operation using the tool with part 16 and part 22, instead of part 4, always fitted to the stem, on the side opposite that indicated in the figure to fit the second wedging washer - roller bushing - sealing ring unit.

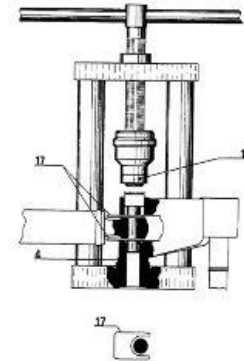

WARNING

BEFORE PROCEEDING WITH THE DESCRIBED PRE-FITTING, DIP THE SEALING RINGS IN MINERAL OIL AND THE "NADELLA" ROLLER BUSHINGS (PREVIOUSLY WASHED IN PURE PETROL OR NEUTRAL PETROLEUM TO ELIMINATE THE ANTI-RUST PROTECTION), HALF-FILLED WITH GREASE.

Specific tooling

020021Y Front suspension service tool

Recommended products

Multi-purpose grease "Multi-purpose" lithium and medium fibre-based yellow brown grease suitable for various uses.

ISO L-X-BCHA 3 - DIN 51 825 K3K -20

- Use the tool fitted with part 20 on its stem and part 21 on the tool base as shown in the figure.
- By moving the tool hand-grip, push the two NADELLA bushings until their internal bottoms make contact with the pin end.
- Use the tool fitted with parts 3 and 4 to fit the pin, and press moving the tool hand-grip, until wedging the washers on the swinging hub.

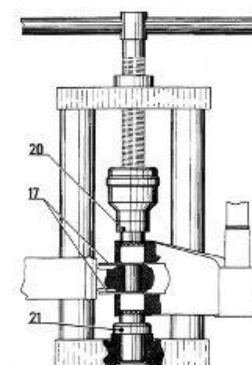

- Now, remove the two spacers (parts 17 and 16) and, once the space between the NADELLAs - steering tube and swinging hub - has been fully filled with grease, move the dust gaiter rings until they are placed in that space.
- By wedging the washers as described above, the front suspension unit refitting stage is finished.

Recommended products

Multi-purpose grease "Multi-purpose" lithium and medium fibre-based yellow brown grease suitable for various uses.

ISO L-X-BCHA 3 - DIN 51 825 K3K -20

Refitting

FITTING

Partially insert the steering tube into the headstock, position the front mudguard on the steering tube and tighten the fixing screws to the prescribed torque, paying attention to the passage of the brake piping and the wiring of the ABS sensor.

Locking torques (N*m)

Front mudguard - Steering tube 5 - 6.5 Nm

Finish inserting the steering tube on the headstock.

Pay attention to the passage of the brake piping and the wiring of the ABS sensor.

Make sure that the lower steering bearing is correctly positioned in its seat of the ball cage.



Supporting the steering tube at the bottom, grease the lower track of the steering bearing with the recommended product and position the ball cage.

Recommended products

Calcium based grease Calcium grease

Smooth-textured appearance; Ivory coloured

Specification TL 9150 066, symbol NATO G 460



Screw on the lower ring nut.



Tighten the lower ring nut to the prescribed torque.

Locking torques (N*m)

Lower steering ring nut - Steering headstock
12 - 14 Nm



Insert the safety plate.



Screw on the upper ring nut.



Tighten the upper ring nut to the prescribed torque.

Locking torques (N*m)

Upper steering ring nut - Steering headstock
35 - 40 Nm



Reposition the protective collar.



Insert the retention clamp of the front brake piping and the wiring of the ABS sensor into its seat on the steering tube.



Fix the front brake piping and the wiring of the ABS sensor with a Velcro tie at the cable gland at the red marking on the relative clamp of the steering tube.



Refit the front shock absorber.

Refit the brake calliper.

Fit the front wheel.

Refit the handlebars.

Refit the rear handlebar cover.

Refit the front handlebar cover.

Refit the front centre cover.

Refit the rear-view mirrors.

Front shock absorber

Removal

Rest the vehicle on its centre stand.

Remove the front wheel.

Unscrew the inside screws fixing the cover of the steering tube to the front mudguard.



Unscrew the outside screw fixing the steering tube cover and remove it.



Unscrew the lower screws fixing the shock absorber to the support.



Unscrew the upper screws fixing the shock absorber to the steering tube.



Remove the shock absorber.

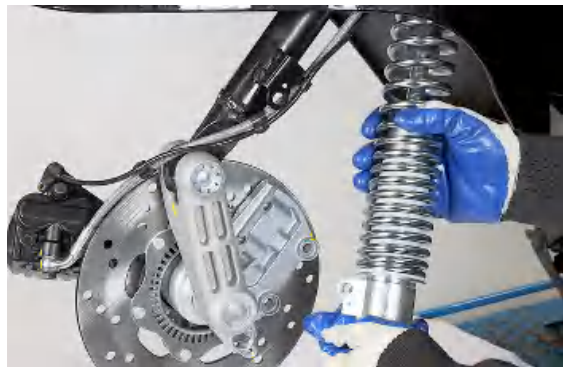

Refitting

Reposition the shock absorber in its seat.

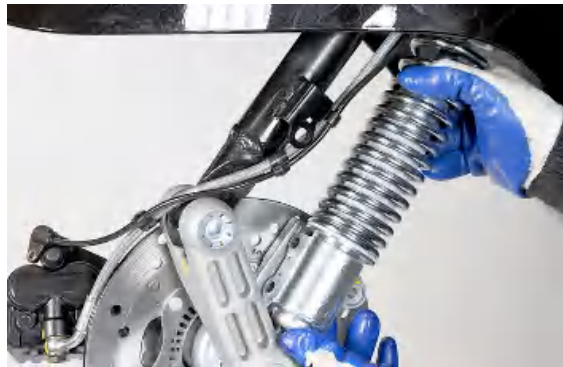

Tighten the upper screws fixing the shock absorber to steering tube with the prescribed torque.

Locking torques (N*m)

Front shock absorber (upper fixing) - Steering tube 19 - 29 Nm



Tighten the lower screws fixing the shock absorber to the support with the prescribed torque.

Locking torques (N*m)

Front shock absorber (lower fixing) - Shock absorber support 19 - 26 Nm



Reposition the cover of the steering tube and tighten the outside screw to the prescribed torque.

Locking torques (N*m)

Steering tube cover - Steering tube 4 - 7 Nm



Tighten the inside screws of the cover of the steering tube to the front mudguard with the prescribed torque.

Locking torques (N*m)

Steering tube cover - Front mudguard 2 - 4 Nm



Shock-absorber - calliper bracket

Removal

Rest the vehicle on its centre stand.

Remove the front wheel.

Remove the front brake calliper.

Remove the speed sensor.

Remove the front wheel hub.

Remove the front shock absorber.

Remove the Seeger ring

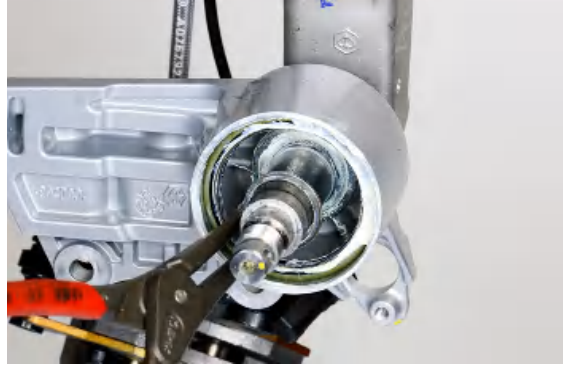

Remove the special washer.



Remove the brake calliper-shock absorber support.



Recuperate the adjustment washer and the O-ring.



Overhaul

Using a flat-head screwdriver, remove the hub side dust gaiter.



Using a flat-head screwdriver, remove the dust gaiter on the shock absorber side.



Using the specific tool, remove the roller cages.

Specific tooling

020365Y 22 mm guide

020376Y Adaptor handle

020441Y 26 x 28 mm adaptor



After checking the roller cage seat on the support, use the specific tool to install a new roller cage on the wheel hub side.

Specific tooling

020037Y Punch



Using the specific tool, install a roller cage on the front shock absorber side.

Specific tooling**020036Y Punch**

Using the specific tool, install a dust gaiter on the shock absorber side.

Specific tooling**020365Y 22 mm guide****020376Y Adaptor handle****020441Y 26 x 28 mm adaptor**

Using the specific tool, install a new dust gaiter on the wheel hub side.

Specific tooling**020360Y 52 x 55 mm adaptor****020376Y Adaptor handle**

Refitting

Insert a new adjustment washer and a new O-ring.



Insert the brake calliper-shock absorber on the wheel axle after greasing the seats of the roller cages with the recommended product.

Recommended products

Calcium based grease Calcium grease

Smooth-textured appearance; Ivory coloured
Specification TL 9150 066, symbol NATO G 460



Insert the special washer on the front wheel axle and make sure it is fully into its seat.



insert the locking Seeger ring of the support.

Refit the front shock absorber.

Refit the front wheel hub.

Refit the speed sensor.

Refit the front brake calliper.

Fit the front wheel.



Check the "Y" distance between the speed sensor and the tone wheel:

If the "Y" distance is less than 0.7 mm, add an appropriate calibrated washer.

If the "Y" distance is greater than 1.9 mm, remove a calibrated washer.

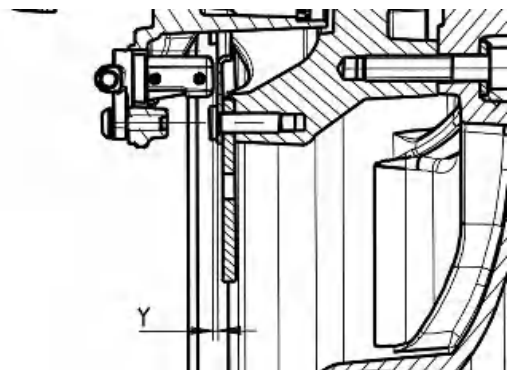

Steering bearing

Removal

Remove the lower ball cage from the steering tube.



Remove the lower plate of the steering bearing from the steering tube.



Using the specific tool, remove the track of the lower steering bearing on the steering headstock.

Specific tooling

020004Y Punch for removing steering bearings from headstock



Using the specific tool, remove the track of the upper steering bearing on the steering headstock.

Specific tooling

020004Y Punch for removing steering bearings from headstock

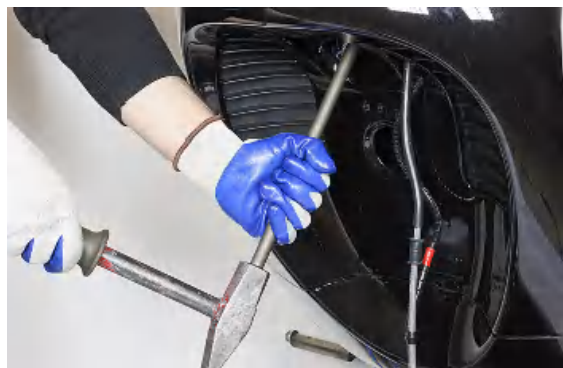

Refitting

Insert the specific tool and the upper track of the lower steering bearing into the steering headstock.

Specific tooling

001330Y Tool for fitting steering seats



Insert the lower plate of the upper steering bearing into the specific tool and tighten the nut.



Make sure the tracks go all the way onto the steering headstock.

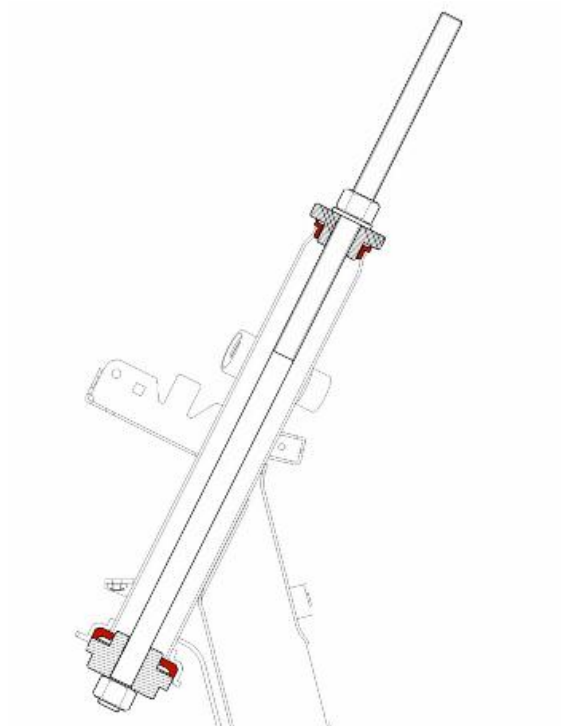

Using the specific tool, refit the lower plate of the steering tube bearing.

Specific tooling

020459Y Punch for fitting the bearing on the steering tube



Grease the track of the seat of the steering bearing with the recommended product.

Reposition the ball cage and refit the steering tube onto the headstock.

Recommended products

Calcium based grease Calcium grease

Smooth-textured appearance; Ivory coloured
Specification TL 9150 066, symbol NATO G 460



Rear

REAR SUSPENSION

Name	Torque in Nm
Retainer for left shock absorber to crankcase support plate	20 - 25
Shock absorber lower fitting	40 - 45
Shock absorber upper fitting	20 - 25
Rear wheel axle	104 ÷ 126
Screw fixing wheel to hub	20 - 25
Screws for silencer - shock absorber support arm on engine	20 - 25 (The two screws must be tightened after having done so with the rear wheel axle nut at the specified torque. Safety fasteners: see «Pre-delivery Operations»)
Engine- and vehicle-side swinging arm junction bolt	40 - 45

Removing the rear wheel

- Remove the complete silencer.
- Remove the silencer mounting bracket.
- Remove the screws fixing the rear wheel to the wheel hub.



Remove the rear wheel.



Refitting the rear wheel

Refit the rear wheel on the wheel hub.



Tighten the screws fixing the rear wheel to the wheel hub to the specified torque.

Refit the silencer support bracket.

Refit the silencer.

Locking torques (N*m)

Rear wheel - Rear wheel hub 20 - 25 Nm



Swing-arm

Removal

- Place the vehicle on its centre stand;
- Remove the engine housing
- Remove the swinging arm/engine fitting shown in the picture
- Move the engine back

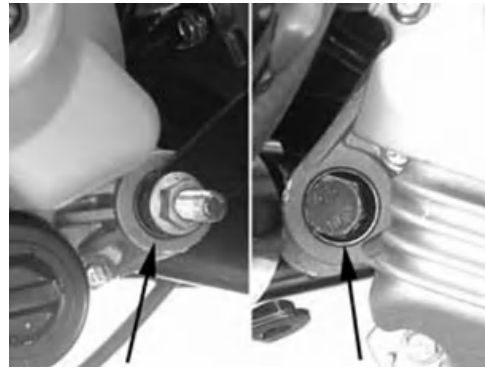

- Remove the spring anchoring the swinging arm to the chassis as shown in the picture



- Remove the two screws fixing the buffer support bracket to the chassis

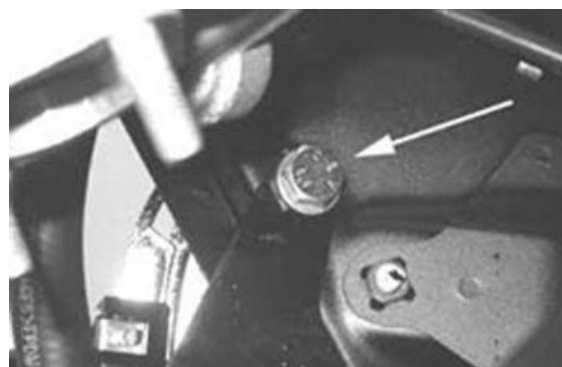

- Remove the left and right caps located under the footrest to reach the pin fixing the swinging arm to the body.
- Remove the pin. Then remove the swinging arm



- Check the entire swinging arm assembly.
- Check all the centring bushing components and silent block rubber buffers.
- Replace the work components that cause excessive clearance on the rear suspension.



Overhaul

- Check there is no sticking in the movement of the connection of the swinging arm on the engine side to the swinging arm on the chassis side.
- Check the axial clearance between the two swinging arms using a feeler gauge



Characteristic

Standard clearance

0.40 - 0.60 mm

Allowable limit after use:

1.5 mm

- In order to check the clearance of the swinging arm on the frame side, prepare a retainer using the fixing pin of the swinging arm on the frame and two rings from the special tool 020229Y. Alternatively, use two washers with 12-mm inside diameter for pins, minimum 30-mm outside diameter and 4-mm thick at least.



- Check there is no sticking in the rotation.
- Check the axial clearance of the swinging arm on the chassis side

**Characteristic
Standard clearance**

0.40 - 0.60 mm

Allowable limit after use:

1.5 mm



- Separate the swinging arm on the engine side from the vehicle side arm.
- Remove the plastic bushings and the internal spacer shown in the picture

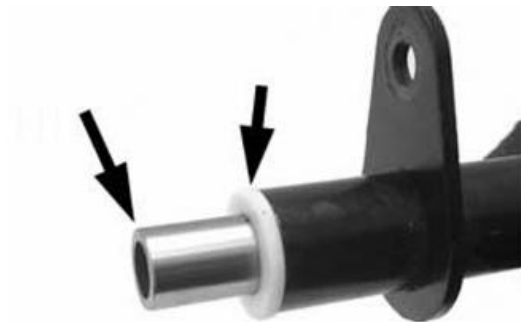

- Using a suitable pin remove the roller casings as shown in the pictures



- Using an appropriate tool plant new roller casings, being careful to position the bearings with the seal rings facing outwards

Specific tooling

020244Y punch \varnothing 15

020115Y punch \varnothing 18

Characteristic

Length of the swinging arm tube on the engine side:

L 175.3 + 0.3 0

Length of the internal swinging arm spacer on the engine side:

L 183 + 0.3 0

Engine side swinging arm plastic bushing shim:

3.5 \pm 0.05 mm

Chassis side swinging arm plastic bushing shim:

3.5 \pm 0.05 mm

Length of the internal swinging arm spacer on the chassis side:

290 \pm 0.1 mm

Length of the swinging arm tube on the chassis side:

283 \pm 0.1 mm



- Lubricate roller casings and the plastic bushings with grease
- Insert the spacers
- Assemble the two arms with the relative bolt in the position shown in the picture
- Adjust the bolt as shown in the picture
- Position the chassis side swinging arm with the most protruding part pointing towards the silent block side as shown in the picture



Recommended products

Calcium based grease Calcium grease

Ivory coloured calcium grease; TL 9150 066;

NATO G 460

- Make sure the silent bloc is not broken. If it is, replace the coupling
- Remove the Seeger ring shown in the picture

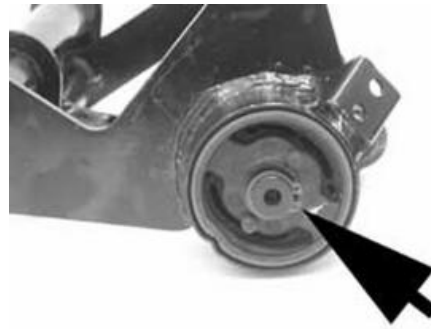

- Remove the full silent bloc bracket
- Undo the silent bloc ring shown in the picture



- Hold the full silent bloc bracket in the clamp
- Using the appropriate tool, remove the silent bloc from the bracket from the side corresponding to the inside of the vehicle. This is to guarantee the tool is centred properly on the support



- Install a new silent bloc, making sure it aligns properly with the reference tooth.
- Fit the silent blocs, making sure the chamfered part of the silent bloc matches the chamfered part of the bracket



- Using the appropriate tool, fit the silent bloc as shown in the picture



Refitting

- To refit, perform the removal operations in reverse.
- Grease the bearings and the rolling parts with the recommended grease.
- Complete the fitting by tightening the nuts on the relative bolts to the proper tightening torque.

Locking torques (N*m)

Engine- and vehicle-side swinging arm junction bolt 40 - 45
Swinging arm pin - Engine 64 - 72
Body shell - Swinging arm pin 76 to 83
Screw fixing the silent-block support plate to the body 42 to 52

Shock absorbers

Removal

Proceed as follows:

- set the vehicle on its centre stand and support it adequately.
- Remove the luggage rack.
- Remove the silencer.
- Unscrew and remove the right shock absorber lower fixing nut.



- Unscrew and remove the left shock absorber lower fixing screw.



- Support the shock absorbers and unscrew its top fixing nuts.

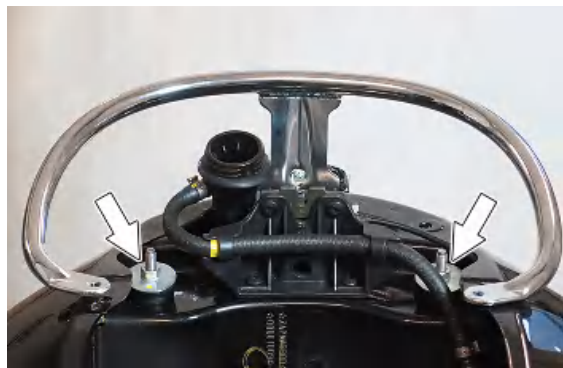

Refitting

For fitting, proceed as follows:

- Insert the top attachment of the rear shock absorbers into the seat in the chassis.
- Tighten the nuts to the specified torque.

Locking torques (N*m)

Rear shock absorber - Chassis 20 - 25 Nm

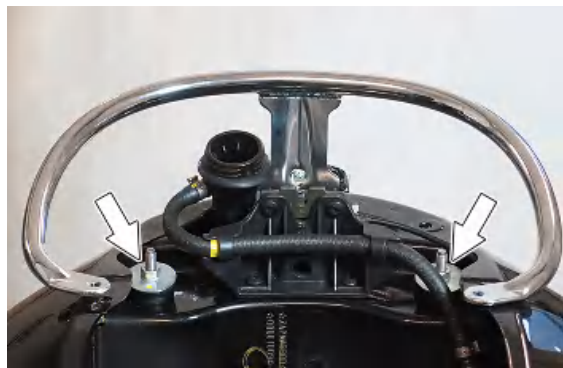

- Insert the lower fixing bolt of the left shock absorber.
- Tighten the bolt to the specified torque.

Locking torques (N*m)

Rear shock absorber - Engine 40 - 45 Nm



- Insert the lower fixing bolt of the right shock absorber and tighten to the specified torque.
- Fit the silencer.
- Fit the luggage rack.

Locking torques (N*m)

Rear shock absorber - Silencer support bracket 40 - 45 Nm



Exhaust bracket

Removal

To remove the silencer support bracket, proceed as follows:

- set the vehicle on its centre stand and support it adequately.
- remove the silencer.

- Unscrew and remove the screw fixing the rear ABS sensor and the screws of the retention clamps of the relative cable.



- Remove the split pin.



- Remove the cap.



- Unscrew and remove the rear wheel nut.

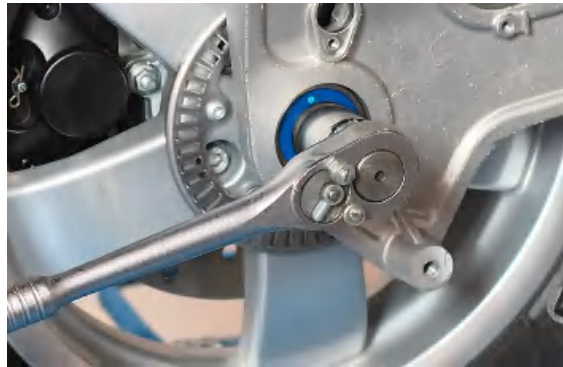

- Remove the spacer.

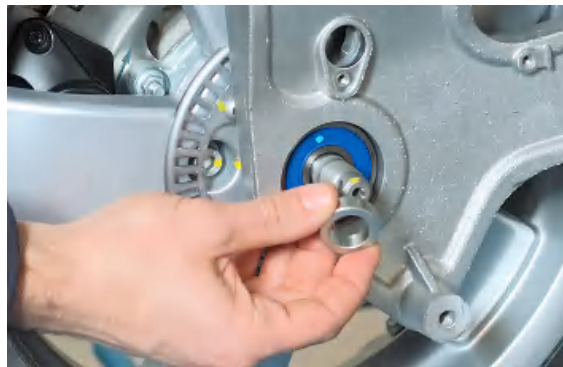

- Unscrew and remove the right shock absorber nut.



- Unscrew and remove the screws fixing the bracket to the engine.

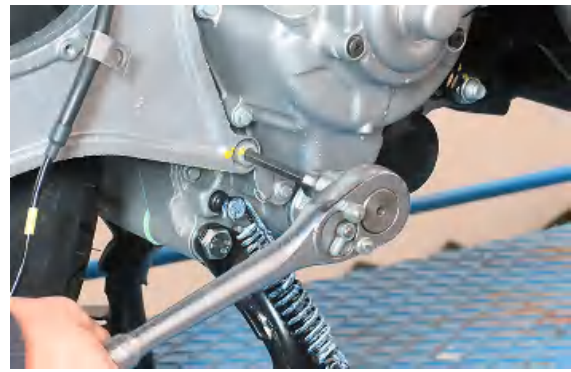

- The silencer support bracket is now free and it can be disconnected from the engine.

Refitting

using the recommended product, lubricate the contact surfaces between the wheel axle and the bearing on the bracket, as indicated in figure. **Take care not to apply the grease to the threaded portion of the wheel axle.**

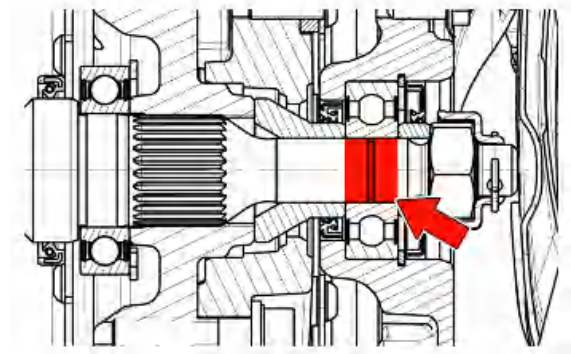

To fit the silencer support bracket, proceed as follows:

- Place the bracket on the engine inserting it onto the wheel pin.
- Insert the spacer.



- Insert the rear wheel nut and tighten to the specified torque.

Locking torques (N*m)

Rear wheel axle nut 104 ÷ 126

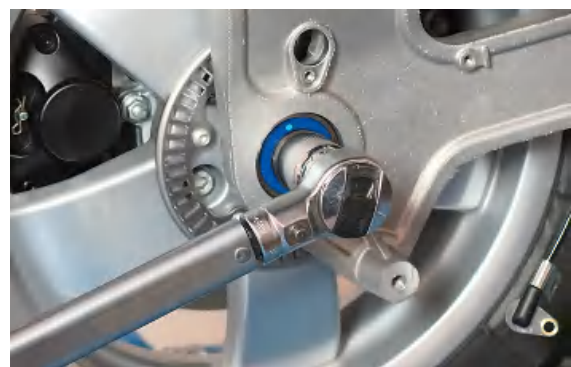

- Insert the cap nut.



- Insert the cotter pin and bend its ends outwards.



- Insert and tighten the screws fixing the bracket to the engine carter to the specified torque.

Locking torques (N*m)

Silencer support bracket - Engine 20 - 25 Nm

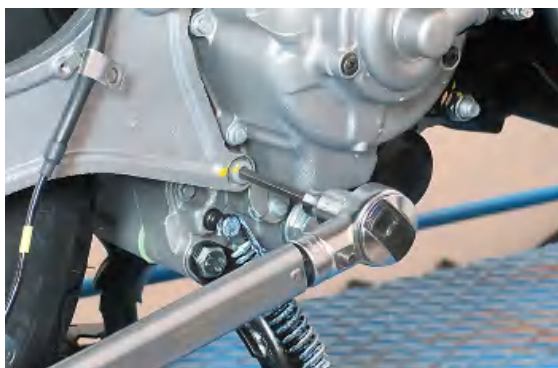

- Insert the lower fixing bolt of the right shock absorber and tighten to the specified torque.

Locking torques (N*m)

Rear shock absorber - Silencer support bracket 40 - 45 Nm



- Insert the rear wheel ABS sensor in its seat and tighten the fixing screws.

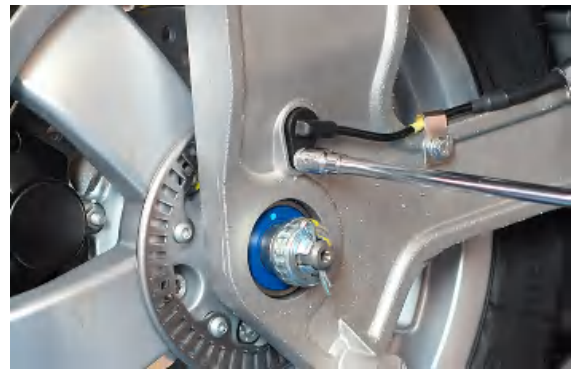

After assembling the sensor in its seat, measure the distance "Y" between the sensor and the tone wheel with a feeler gauge.

If the "Y" measurement is less than 0.4 mm, assemble a calibrated washer between the sensor and the silencer support bracket.

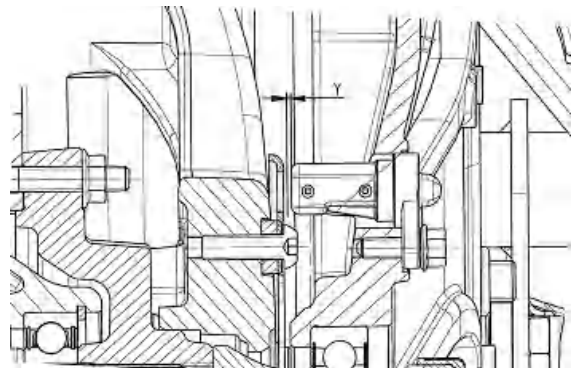

- Fit the silencer.

Centre-stand

REMOVAL

- Use a jack to support the vehicle properly.
- Remove the two return springs from the centre stand.
- Undo the nut shown in the figure.
- Remove the pin from the right side.
- Remove the centre stand.



FITTING

- On refitting tighten the nut to the specified torque.

Locking torques (N*m)

Central stand bolt 32 - 40

Side stand

REMOVAL

- Uncouple the centre stand return spring;
- Remove the screw shown in the photograph

FITTING

To refit, carry out the removal operations in reverse order and comply with the specified torque.

Locking torques (N*m)

Side stand fixing bolt 35 - 40



INDEX OF TOPICS

BRAKING SYSTEM

BRAK SYS

This section is dedicated to the description of the brake system components.

FRONT BRAKE

Name	Torque in Nm
Brake fluid pump-hose joint	20 - 25
Brake fluid pipe-calliper fitting	19 - 24
Screw fixing calliper to the shock absorber - calliper plate attachment	24 to 27
Disc tightening screw	6 (Apply LOCTITE 242 threadlock, medium strength)
Oil bleed screw	12 - 16
Pad fastening pin	19.6 - 24.5
Brake pump reservoir screws	1.5 - 2
Brake disc screws	8 to 10

REAR BRAKE

Name	Torque in Nm
Brake fluid pump-hose joint	20 - 25
Brake fluid pipe-calliper fitting	20 - 25
Rear disc tightening bolt	11 to 13
Oil bleed screw	12-16
Calliper to engine tightening screw	20 - 25
Brake pump reservoir screws	1.5 - 2
Callipers fitting screw	30 - 33 Nm

ABS

CAUTION

When removing the front wheel, for example to change the tyre, be careful not to damage the tone wheel.

Visually check the state of the tone wheel and carry out a road test, making a complete check of the ABS system before shipping the vehicle to the client.

Damage to the tone wheel causes the continual operation of the modulator pump even when the brake lever is not engaged.

CAUTION

WITH EACH REMOVAL AND FITTING OF THE FRONT WHEEL CHECK THE DISTANCE BETWEEN THE SPEED SENSOR AND THE TONE WHEEL, WHICH SHOULD BE BETWEEN 0.5 mm AND 1.5 mm. IF NECESSARY ADJUST IT BY ADDING OR REMOVING 0.5 MM CALIBRATED WASHERS CHECKING THE ABS SYSTEM TAKES PLACE WITH EACH KEY "ON" AND CAN BE REPEATED, ESPECIALLY IN HARSH CLIMATIC CONDITIONS AFTER THE ENGINE STARTS, THIS IS DUE TO THE NATURAL LOWERING OF THE BATTERY VOLTAGE CAUSED BY THE STARTING SYSTEM.

The vehicle is equipped with a locking ABS system on the wheels.

A: Tone wheel

B: Speed sensor

- ABS: It is a hydraulic - electronic device that limits the pressure within the braking circuit when a sensor, located on the wheel, detects its tendency to lock. This system prevents the wheels from locking to avoid the risk of falling.

In case of failure of the ABS system, immediately reported to the rider with ABS warning light on the instrument cluster, the vehicle retains the characteristics of a conventional braking system. In case of ABS warning light, reduce speed and go to an Authorised Service Centre for the appropriate checks.

The safety provided by the ABS does not, in any case, justify risky manoeuvres. The stopping distance may be greater, compared to a conventional vehicle equipped with traditional braking in the following conditions:

- Riding on rough roads, with gravel or snow
- Riding on roads with holes or bumps

It is therefore recommended to reduce speed in these conditions.



AT VERY LOW SPEEDS (LESS THAN 5 KM/H) THE ABS SYSTEM IS DISABLED. IT IS RECOMMENDED TO PAY ATTENTION THEREFORE IN CASES OF BRAKING IN LOW GRIP CONDITIONS AT LOW SPEED (FOR EXAMPLE BRAKING ON GARAGE FLOOR TILES AFTER HAVING RIDDEN ON WET ROADS OR SIMILAR SITUATIONS)

N.B.

THE ABS WARNING LIGHT TURNS ON AND REMAINS ON UNTIL A SPEED OF 5 Km/h IS REACHED.

CAUTION



IN THE EVENT OF MALFUNCTION OF THE BATTERY, THE ABS - ASR SYSTEM TURNS OFF.

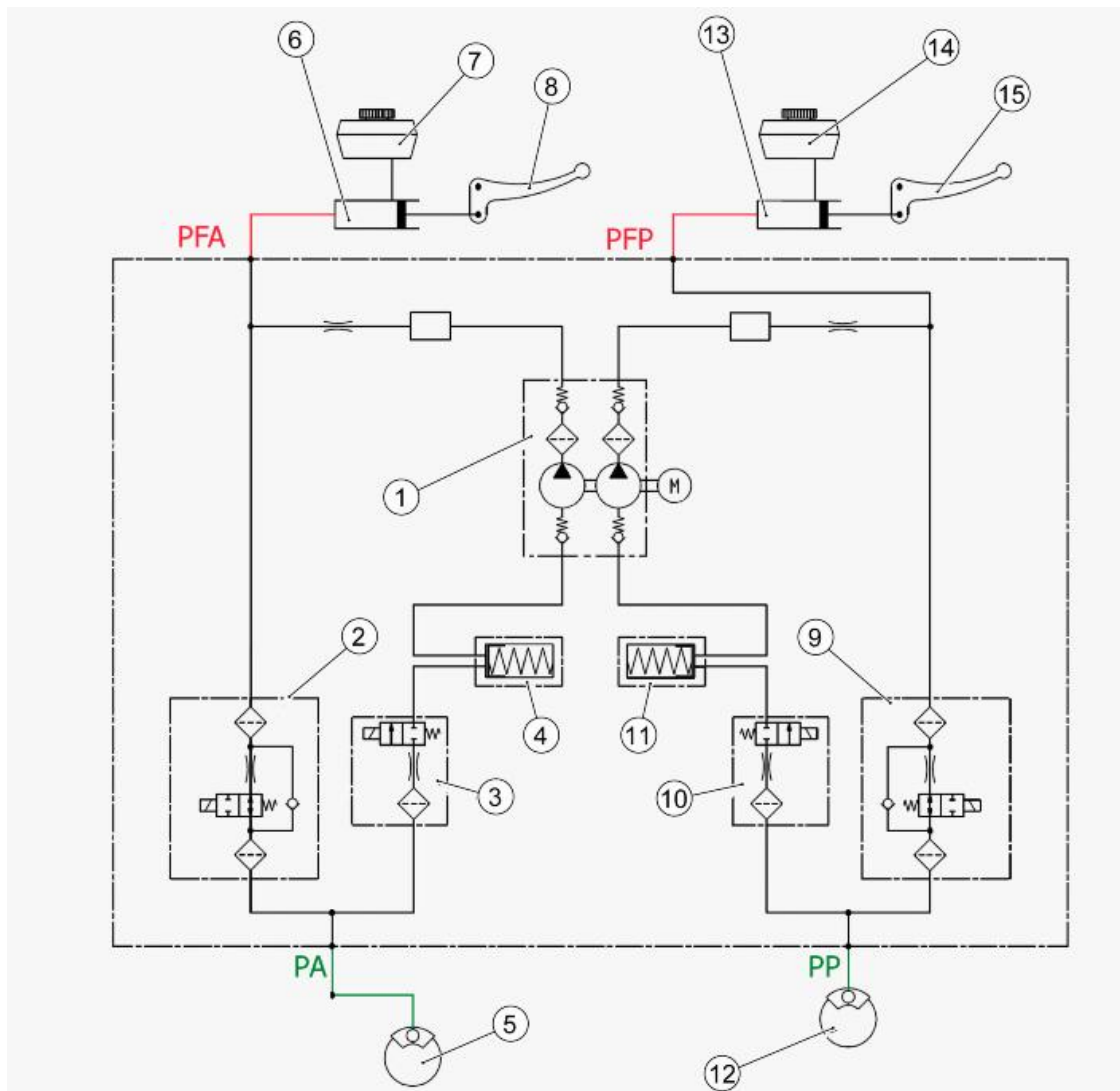

Key:

1. Recirculation pumps
2. Front brake circuit inlet solenoid valve
3. Front brake circuit outlet solenoid valve
4. Front brake circuit low pressure accumulator
5. Front Calliper (PA Pump)
6. Front Brake (PFA)
7. Front Brake Tank
8. Front brake control lever
9. Rear brake circuit inlet solenoid valve
10. Rear brake circuit outlet solenoid valve
11. Rear brake circuit low pressure accumulator
12. Rear Calliper (PP)
13. Rear Brake Pump (PFP)
14. Rear Brake Tank
15. Rear brake lever

OPERATION OF THE ABS

General considerations

- The front circuit is the same as the rear one.
- The ABS intake valve (2 - 9) is normally open and is closed only when the system intervenes to prevent locking.
- The exhaust valve (10 - 3) is normally closed and is only opened when the system intervenes to prevent locking.
- With the system in stand-by mode, the ABS processor controls the wheel speed instant by instant to assess any slippage of the wheels.
- While in stand-by, the system does not intervene in any way on the braking of the rider, the braking system is identical to the one without ABS.
- ABS Cycle phases (the following operations refer to the front circuit but they are also valid for the rear):

A - Start braking: The rider starts to brake like in normal braking.

B - Pressure reduction: coincides with the recognition of the dangerous situation (wheel slippage exceeds the threshold): The system closes the intake valve (2 - 9) and temporarily opens the exhaust valve (10 - 3). In this phase, the rider cannot increase the pressure of the callipers (12 - 5) and the system reduces the pressure in the callipers. The excess fluid temporarily fills the front tank (14 - 7) until the ABS pump (1) self-operates by driving the fluid in the direction of brake pump (6 - 13).

C - Maintaining pressure: the pressure in the callipers (12 - 5) remains low until the full restoration of speed / grip of the wheel. The system returns the fluid removed from the calliper (12 - 5) to the system section between the brake pump (6 - 13) and the ABS intake valve (2 - 9).

D - Pressure restoration: through the temporary openings of the intake valve (2 - 9), pressure from the callipers (12 - 5) is increased until the maximum deceleration has been reached, the system then re-assigns braking control to the rider.

E - In the event that the wheel does not regain full grip, the system continues to operate as before until it is restored or until the vehicle stops. An error may be generated, however, if the pressure reduction stage persists for longer than a predetermined limit.

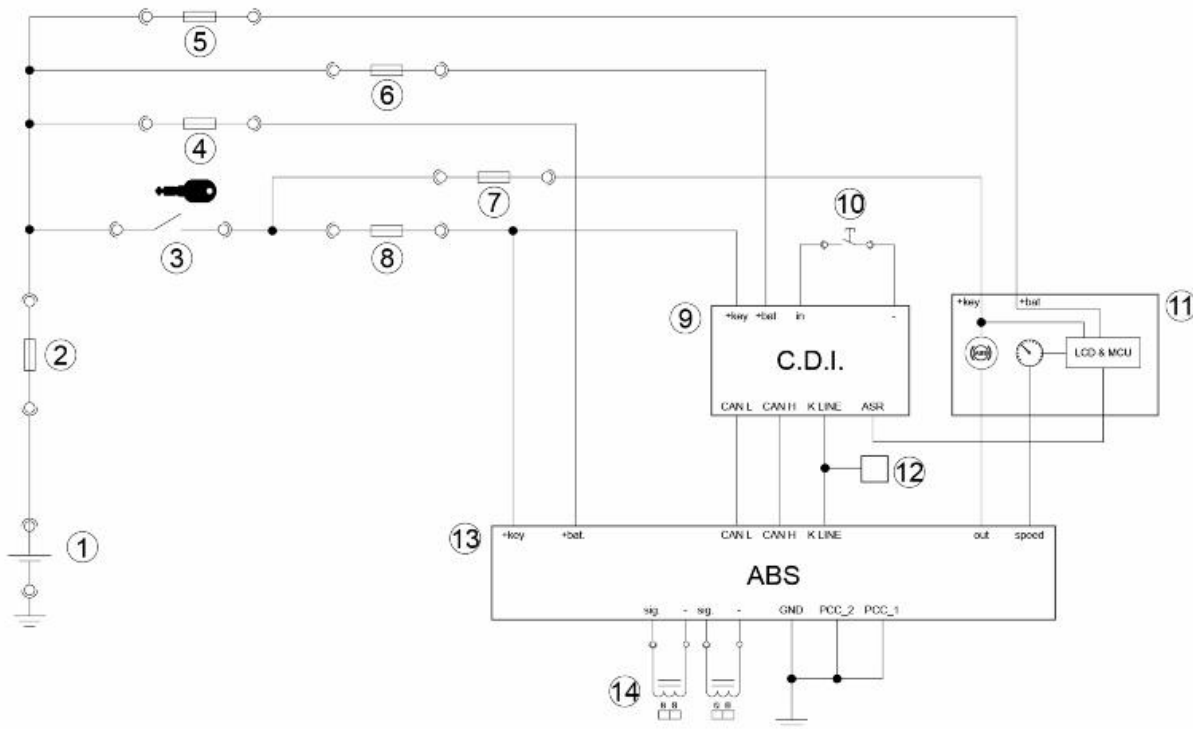

1. Battery
2. Fuse no.1 - 30A
3. Ignition switch
4. Fuse no.5 - 25A
5. Fuse No. 6; 15A
6. Fuse no.7 - 10A
7. Fuse no.2 - 7.5A
8. Fuse no.4 - 7.5A
9. Electronic injection control unit
- 10.ASR button
- 11.Instrument panel
- 12.Diagnostic port
- 13.ABS control unit
- 14.ABS sensors

Guide to diagnosis

At each key ON, if at least one current error or one stored in the system is not immediately detected:

- the ABS warning light flashes.

Once vehicle speed exceeds 5 km/h (3.11 mph):

- If no errors are detected the ABS warning light turns off
- If at least one malfunction is detected, the ABS warning light turns on permanently.

The ABS system is disabled!

The system is still fully functional like any other brake system without ABS.

The detection of malfunctions may require more or less time depending on the type of fault.

Following the detection logic one or more conditions must persist within a certain time to detect errors.

If during this time one of the conditions is lost and then reappears, the timer is reset and the system is not able to detect the fault.

The ABS system continues to be inactive.

Example:

the error code 5D93 takes a few minutes before being diagnosed, so in this period, the ABS warning light continues to flash.

GUIDE TO ABS FAULT DIAGNOSIS

1. ABS LAMP ON

2. CONNECT THE DIAGNOSTIC TOOL

DOES THE DIAGNOSTIC TOOL COMMUNICATE? (NO, go to point 3; YES, go to 4)

3. CHECK THE ABS CONTROL UNIT POWER SUPPLY.

4. ARE THERE ANY ERRORS? YES, go to point 5; NO, go to point 6)

5. CONSULT THE ERRORS DISPLAY TABLE

6. ABS WARNING LIGHT ACTIVATION

IS IT ACTIVATED?(YES, go to point 7; NO, go to point 8)

7. CONTACT TECHNICAL SERVICE

8. PERFORM THESE CHECKS:

- A. Continuity in cable between PIN 10 of ABS unit connector and PIN 16 of instrument cluster.
- B. Check connectors - see operations described in the chapter.

If the above checks are OK, the causes can be:

- C. ABS Control unit malfunction
 - D. Instrument panel malfunction
-

Modulator

REMOVAL

CAUTION



IT IS EXTREMELY IMPORTANT TO CAREFULLY FOLLOW THE REMOVAL AND REASSEMBLY PROCEDURES DESCRIBED BELOW. THESE PROCEDURES MAKE IT POSSIBLE TO AVOID AIR FROM ENTERING THE BRAKING CIRCUIT AND ESPECIALLY IN THE ABS MODULATOR WHILE REPLACING THE COMPONENTS.

Support the vehicle adequately.

Remove the handlebar covers.

Remove the leg shield back plate.

Remove the front centre cover.

Remove the wheels.

Unscrew the screws on the rear brake hose fastening clamps.



Unscrew and remove the front brake calliper fixing screws and remove it from the support.

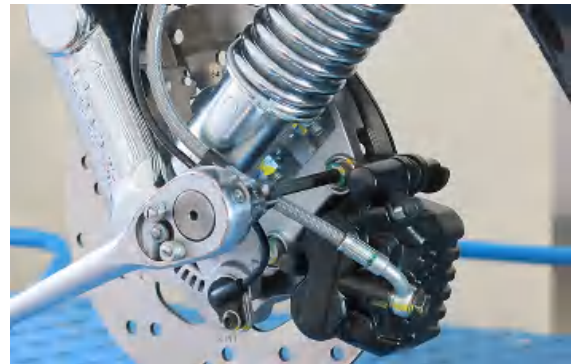

With new pads or pads in a good condition, operate the brake pump repeatedly to bring the pads in contact with each other.



Refill the front brake pump tank and fit the cap.



Operate the brake lever just beyond the point of closing communication with the tank.
Block the position of the lever by fastening it.



Undo the fixing screws of the rear brake calliper to the engine.



With new pads or pads in a good condition, operate the brake pump repeatedly to bring the pads in contact with each other.

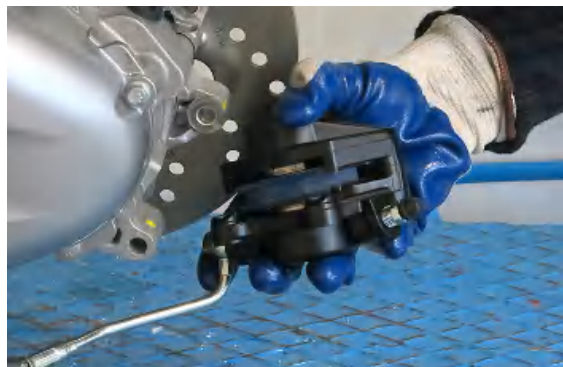

Refill the rear brake pump tank and fit the cap.



Operate the brake lever just beyond the point of closing communication with the tank.
Block the position of the lever by fastening it.



Unscrew the fixing nuts and remove the turn indicators device including bracket.



Disconnect the front tone wheel sensor connector.



Open the hydraulic hoses fastening clamp.



Disconnect the modulator connector.

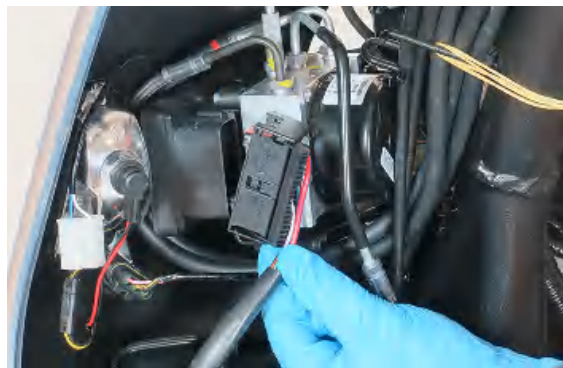

Unscrew the connectors fastening the circuit pipes entering and exiting the modulator.

N.B.

PAY ATTENTION TO THE LOSS OF BRAKE FLUID DURING THE REMOVAL OF THE PIPING FROM THE MODULATOR. USE A SMALL CONTAINER AND A CLOTH.

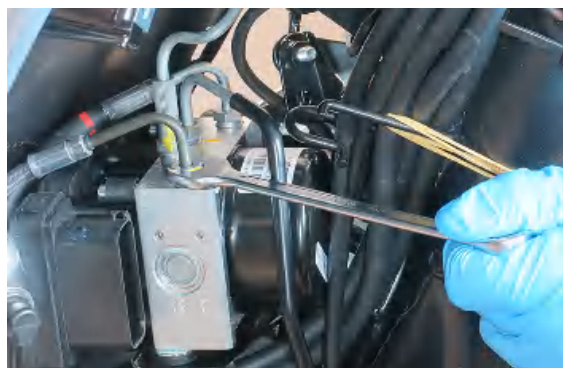

Through the front opening of the shield, unscrew and remove the modulator fixing screw to the side support bracket.



Undo and remove the fastening nuts of the modulator lower support bracket



Remove the modulator complete with lower support bracket.



Separate the ABS modulator from the lower support bracket by unscrewing the fastening screws.



FITTING

Install the new modulator on the support bracket, tightening the fastening screws to the specified torque.

Locking torques (N*m)

ABS Modulator - Bracket 8 - 10 Nm



Insert the ABS modulator complete with bracket in its seat.



Through the front opening of the shield, insert and tighten the modulator fixing screw at the prescribed torque to the side support bracket.



Locking torques (N*m)

ABS Modulator - Bracket 8 - 10 Nm

Unscrew the seal plug on the RW outlet of the modulator.

N.B.

PAY ATTENTION TO THE LOSS OF BRAKE FLUID DURING THE REMOVAL OF THE PIPING FROM THE MODULATOR. USE A SMALL CONTAINER AND A CLOTH.



Connect the pipe supplying the rear calliper to the RW outlet on the modulator.

Screw in the connector all the way and then loosen it half a turn.



Slowly move away the rear calliper pads.



Until the brake fluid exits the slow connector.
Block the connector on the modulator while the fluid is exiting.

CAUTION



THE CONNECTOR MUST BE TIGHTENED BEFORE REMOVING THE THRUST FROM THE PADS. OTHERWISE, AIR ENTERS THE PIPE.



Unscrew the seal plug on the RC inlet of the modulator.

N.B.

PAY ATTENTION TO THE LOSS OF BRAKE FLUID DURING THE REMOVAL OF THE PIPING FROM THE MODULATOR. USE A SMALL CONTAINER AND A CLOTH.



Move the rear calliper pads further away until the brake fluid exits from the seat of the RC inlet.

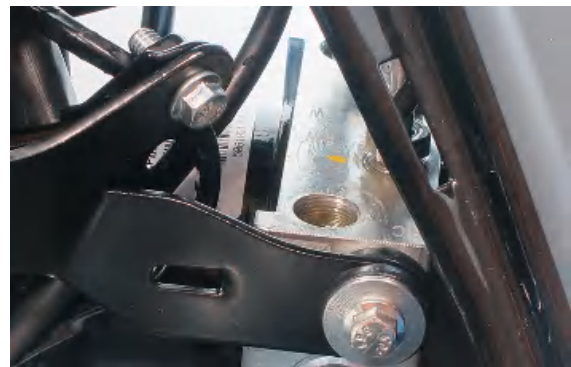

Connect the rear brake master cylinder delivery pipe to the RC outlet on the modulator.
Screw in the connector all the way and then loosen it half a turn.



Pull the rear brake lever until brake fluid and air slowly exit the RC connector.
Block the connector while the brake fluid is exiting.

CAUTION

THE CONNECTOR MUST BE TIGHTENED BEFORE RELEASING THE BRAKE PUMP LEVER. OTHERWISE THE PUMP INTAKES AIR IN THE PIPE.



Free the rear brake pump lever.



Check and if necessary top up the level of the brake fluid in the brake pump tank.
Close the tank cap.



Refit the rear brake calliper on the disc, tightening the screws to the specified torque.

Actuate the brake pump lever, recovering the distance of the pads.

Check the system's efficiency.

If the work was performed properly, the brake must be efficient.

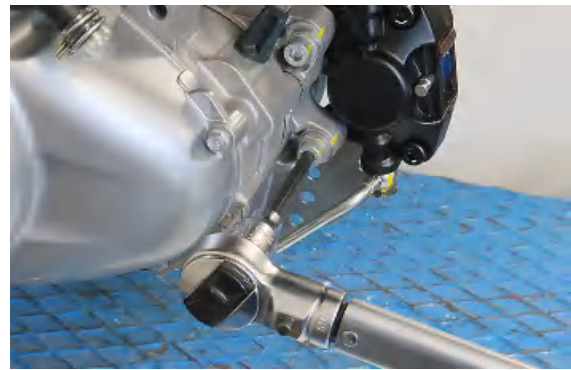

Locking torques (N*m)

Rear brake calliper screws - Engine 20 - 25 Nm

Proceed in the same manner to connect the front brake pipes.

Unscrew the seal plug on the FW outlet of the modulator.

N.B.

PAY ATTENTION TO THE LOSS OF BRAKE FLUID DURING THE REMOVAL OF THE PIPING FROM THE MODULATOR. USE A SMALL CONTAINER AND A CLOTH.



- Connect the pipe supplying the front calliper to the FW outlet on the modulator.

Screw in the connector all the way and then loosen it half a turn.



Slowly move away the front calliper pads.



Until the brake fluid exits the slow connector.
Block the connector on the modulator while the fluid is exiting.

CAUTION

THE CONNECTOR MUST BE TIGHTENED BEFORE REMOVING THE THRUST FROM THE PADS. OTHERWISE, AIR ENTERS THE PIPE.

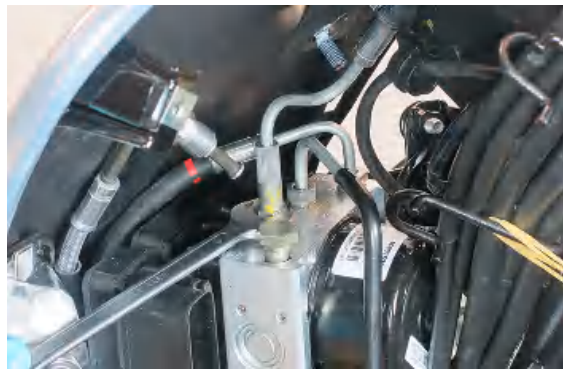

Unscrew the seal plug on the FC inlet of the modulator.

N.B.

PAY ATTENTION TO THE LOSS OF BRAKE FLUID DURING THE REMOVAL OF THE PIPING FROM THE MODULATOR. USE A SMALL CONTAINER AND A CLOTH.

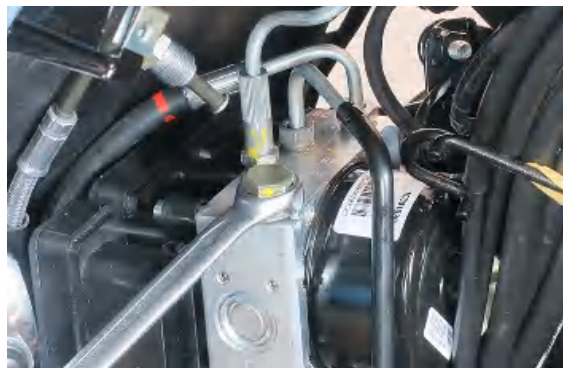

Move the front calliper pads further away until the brake fluid exits from the seat of the FC inlet.



Connect the front brake master cylinder delivery pipe to the FC outlet on the modulator.
Screw in the connector all the way and then loosen it half a turn.

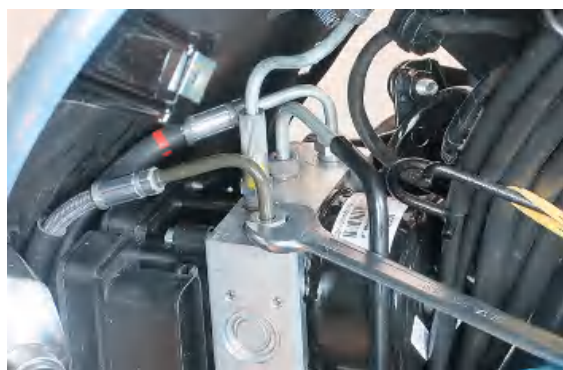

Pull the front brake lever until brake fluid and air slowly exit the FC connector.

Block the connector while the brake fluid is exiting.

CAUTION



THE CONNECTOR MUST BE TIGHTENED BEFORE RELEASING THE BRAKE PUMP LEVER. OTHERWISE THE PUMP INTAKES AIR IN THE PIPE.



Free the front brake pump lever.



Check and if necessary top up the level of the brake fluid in the brake pump tank.

Close the tank cap.



Refit the front brake calliper on the disc, tightening the screws to the specified torque.

Actuate the brake pump lever, recovering the distance of the pads.

Check the system's efficiency.

If the work was performed properly, the brake must be efficient.

Locking torques (N*m)

front brake calliper shock absorber and brake calliper support 19 - 24 Nm



Block the hydraulic hoses with the appropriate clamp



Connect the connector to the modulator until the click of the stop tooth is heard.

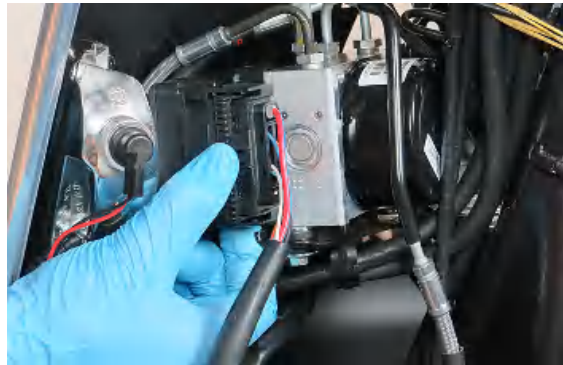

Connect the front tone wheel sensor connector.



Connect the direction indicator device connector



Position the direction indicator device complete with bracket in its seat
Insert and tighten the bracket fixing nuts.



Insert and tighten the screws of the rear brake pipe fastening clamps.

Assemble the wheels.

Assemble the front centre cover.

Assemble the leg shield back plate.

Fit the handlebar covers.



ASR

System ASR

ASR SYSTEM

The ASR system is a driving aid that assists the driver in acceleration manoeuvres, particularly on low-grip surfaces or under conditions that can cause sudden back-wheel slippage. The ASR in these situations automatically intervenes by reducing engine output within the limit imposed by the grip conditions, contributing significantly to the maintenance of stability the vehicle.

WARNING



THE ASR SYSTEM IS BASED ON THE RECOGNITION OF SPEED DIFFERENCES BETWEEN FRONT AND REAR WHEEL. IN ORDER FOR THE SYSTEM TO MAINTAIN MAXIMUM EFFICIENCY IN ALL CONDITIONS, THE CALIBRATION PROCEDURE MUST BE PERFORMED EVERY TIME, EVEN IN CASE OF REPLACEMENT OF JUST ONE TIRE. FOR THE CALIBRATION OF THE CONTROL UNIT PERFORM THE PROCEDURE BELOW.

ASR BUTTON 1: activation / deactivation.

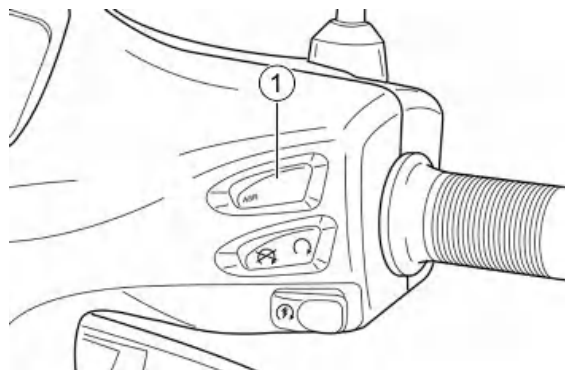

ASR ICON 2: ASR status indicator icon.

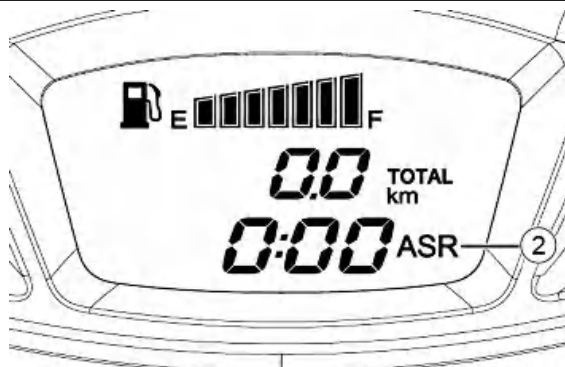

ASR ICON FLASHING MODE:

- Frequency of 5 flashes per second (5Hz), with vehicle running: The system is functioning correctly and is active (poor grip conditions, engine power limiting in effect); ride with extreme care, as the grip limit has been exceeded; restore the vehicle safety conditions by gently reducing the throttle opening.

- Frequency of 1 flash per second (2 Hz), with the key in "ON" position and the vehicle at a standstill:
The system is active and the calibration is performed. The corresponding icon will switch off as soon as the ABS system becomes operational.

- Frequency of 1 flash every 2 seconds (0.5 Hz), with the key in "ON" position and the vehicle at a standstill: the system calibration is in progress.

- Switched on steady can have three meanings:

1. calibration procedure performed incorrectly. Perform a new calibration;
2. the ASR system is not operating and will not intervene in case of loss of grip;
3. the ASR system has been willingly disabled.
 - If the deactivation was voluntary (by pressing the appropriate button "1" for 1 second with the engine running) it is recommended to reactivate the system as soon as possible.
 - If the system was NOT deactivated voluntarily, this indicates a failure of the ASR system: In this case, proceed with the system diagnosis and reactivation.

To ensure maximum safety of the vehicle it is advisable to keep the system active. Deactivation may be necessary only in case of starting with very low grip surfaces (mud, snow) on which the operation of the ASR could actually prevent the movement of the vehicle.

N.B.

UPON KEY "ON", THE ASR ICON FLASHES AT THE SAME FREQUENCY AS THE ABS INDICATOR LIGHT TO INDICATE THAT SYSTEM DIAGNOSIS IS IN PROGRESS. IF NO ERRORS ARE FOUND, THE ASR ICON AND THE ABS INDICATOR LIGHT SWITCH OFF AT THE SAME TIME ONCE THE VEHICLE SPEED EXCEEDS 5 Km/h (3 mph).

IF THE ICON AND INDICATOR LAMP DO NOT FLASH WHEN THE ENGINE IS STARTED, THE SYSTEM MAY NOT BE WORKING.

WARNING



THE ASR SYSTEM IS ACTIVATED AT EVERY "ON" POSITIONING OF THE IGNITION SWITCH. IF DISABLED BY THE USER, THE ASR SYSTEM KEEPS THE STATE OF INACTIVITY ONLY IF THE VEHICLE IS OFF, BY USING THE ENGINE STOP SWITCH; AT THE NEXT KEY ON THE ASR SYSTEM IS ENABLED AUTOMATICALLY.

CAUTION



IT IS EMPHASISED THAT THE RIDING AUXILIARY SYSTEM CANNOT CHANGE THE PHYSICAL LIMITS OF GRIP AND IS NOT A SUBSTITUTE FOR PROPER MANAGEMENT OF POWER, BOTH ON STRAIGHT STRETCHES AND IN TURNS. THEREFORE, IT IS RECOMMENDED TO ALWAYS USE THE VEHICLE WITH THE UTMOST CARE AND IN ACCORDANCE WITH THE REGULATIONS IN FORCE.

CAUTION



AT LOW SPEED, LESS THAN 5 Km/h (3 mph), THE ASR SYSTEM IS NOT OPERATIONAL. IT IS RECOMMENDED TO PAY PARTICULAR ATTENTION IN THE EVENT OF ACCELERATION FROM STANDSTILL IN CONDITIONS OF LOW GRIP, ESPECIALLY IN THE FIRST METRES.

N.B.

IN CASE OF ROAD DISCONNECTIONS THERE COULD BE SHORT ACTIVATIONS OF THE ASR SYSTEM. SUCH EVENT APPEARS UNDER NORMAL OPERATION CONDITIONS OF THE VEHICLE.

N.B.

THE DEVICE PREVENTS IMPRESSING ON THE REAR HIGH SPEED ROTATION WHEEL WITH THE VEHICLE ON THE CENTRE STAND. IT IS RECOMMENDED NOT TO INSIST WITH THE THROTTLE GRIP IN THIS PARTICULAR CONDITION.

CAUTION



A POOR STATE OF MAINTENANCE OF THE TYRES CAN RESULT IN ABNORMAL OPERATION OF THE ASR SYSTEM.

IN CASE OF REPEATED INTERVENTIONS OF THE ASR, EVEN ON ROAD SURFACES WITH GOOD GRIP OR SMALL THROTTLE OPENINGS, IT IS NECESSARY TO CHECK FOR WEAR AND/OR THE STATE OF INFLATION OF TYRES FIRST.

CAUTION



IN THE EVENT OF MALFUNCTION OF THE BATTERY, THE ABS - ASR SYSTEM TURNS OFF.

predelivery ASR SYSTEM calibration/ ECU replacement

In case of predelivery vehicle, or following the replacement of the engine management control unit, **on which the ASR system initialisation procedure has never been performed**, proceed as follows.

After key "ON", the ABS indicator light flashes and the ASR icon "2" **is switched on steady**.

1. Start the vehicle and ride a short distance of more than 5 km/h (3 mph) and wait for the flashing of the ASR warning light to stop. The ASR icon stays switched on steady.

2. Stop the vehicle and leave the engine running at idle speed for at least 3 seconds.

3. Press the engine start button and the ASR on/off button "1" simultaneously for at least 4 seconds **(pulling the left brake lever has no effect)**.

4. The activation of the procedure will be confirmed by the slow flashing switched on ASR icon "2" (1 flash every 2 seconds).

5. Accelerate to a constant speed of 30 km/h (18.7 mph) and maintain it for at least to 10 seconds.

6. The end of the procedure will be indicated by turning off the ASR icon "2".

7. Once the procedure is completed, turn the ignition switch to "OFF" and wait at least 30 seconds for the next key "ON".

8. In case of failure to complete the procedure within 2 minutes the ASR icon "2" will stay on steady and the ASR will remain disabled until the next key "OFF".

9. To restart the ASR, it is necessary to turn the key to "ON", and repeat the procedure until achieving positive result.

ASR SYSTEM CALIBRATION following the replacement of one or both tires

If one or both tires are replaced, proceed in the following manner.

After key "**ON**", the ABS indicator light and the ASR icon "**2**" **flash at the same frequency (fast flashing)**.

1. Start the vehicle and ride a short distance of more than 5 km/h (3 mph) and wait for the flashing of the ASR warning light and of the ABS icon to stop.
2. Stop the vehicle and leave the engine running at idle speed for at least 3 seconds.
3. Turn the ASR system off by pressing the specific button "**1**" on the handlebar and check that the ASR disabling icon "**2**" is switched on steady.
4. Press the engine start button and the ASR on/off button "**1**" simultaneously for at least 4 seconds (**pulling the left brake lever has no effect**).
5. The activation of the procedure will be confirmed by the slow flashing switched on ASR icon "**2**" (1 flash every 2 seconds).
6. Accelerate to a constant speed of 30 km/h (18.7 mph) and maintain it for at least to 10 seconds.
7. The end of the procedure will be indicated by turning off the ASR icon "**2**".
8. Once the procedure is completed, turn the ignition switch to "**OFF**" and wait at least 30 seconds for the next key "**ON**".
9. In case of failure to complete the procedure within 2 minutes the ASR icon "**2**" will stay on steady and the ASR will remain disabled until the next key "**OFF**".
10. To restart the ASR, it is necessary to turn the key to "**ON**", and repeat the procedure until achieving positive result.

Rear brake calliper

Removal

- Remove the silencer.
- Remove the silencer supporting arm.
- Remove the rear wheel.
- Unscrew the screws on the rear brake hose fastening clamps.



Operate the brake lever just beyond the point of closing communication with the tank.
Block the position of the lever by fastening it.



Previously loosen the screw fastening the pipe connector to the calliper.



Undo the fixing screws of the rear brake calliper to the engine.



Extract the calliper from the disc and turn it so that the end part of the pipe is tilted upwards.
Maintaining this position, remove the calliper by acting on the connector with the relative copper washers.

WARNING

KEEP THE END OF THE PIPE TILTED UPWARD.



Suitably protect the connector and secure it so it is tilted upward to keep air from entering.

Immediately proceed with installing the new brake calliper.

CAUTION



BRAKE FLUID IS HYGROSCOPIC; THAT IS, IT ABSORBS MOISTURE FROM THE AIR. IT IS IMPORTANT TO COMPLETE THESE OPERATIONS AS QUICKLY AS POSSIBLE TO AVOID THE DEGRADATION OF THE CHARACTERISTICS OF THE FLUID.



Refitting

Keeping the end of the pipe upwards, connect the new calliper using the connector and the new copper washers.

Keeping the calliper aligned with the vehicle, temporarily block the connector to maintain a seal.



Fasten or maintain the calliper in the up position and free the pump lever.

WARNING

TO RELEASE THE BRAKE LEVER, CUT THE WIRE OF THE FASTENING IN ORDER TO OPEN THE COMMUNICATION WITH THE TANK. AVOID ANY ADDITIONAL OPERATION OF THE BRAKE LEVER.



Keeping the calliper up, connect the drain pipe and open the bleed valve connector.

Allow the air to flow out until only brake fluid exits.

CAUTION

THIS BLEEDING PHASE MUST TAKE PLACE BY MEANS OF GRAVITY. DO NOT ACTIVATE THE PUMP LEVER.



Check and if necessary top up the tank level.



Lower the calliper to the position shown in the photo and open the bleed valve connector again. Let the air flow out and close the bleed valve connector when the level of the brake fluid in the drain pipe has risen at least 10 cm without the outflow of air.



Install the brake calliper on the disc and tighten the fastening screws on the engine to the specified torque.

Locking torques (N*m)

Rear brake calliper screws - Engine 20 - 25 Nm



Loosen the connector fastening the pipe as little as possible to settle the pipe in the neutral position. Finally block the connector to the specified torque.

Locking torques (N*m)

Calliper - brake calliper connector 20 - 25 Nm



Refill the level of the brake fluid and close the tank cover.



Fix the rear brake pipe fastening clamps with the appropriate screws.

Fit the rear wheel.

Assemble the silencer supporting arm.

fit the silencer.



Check the system's efficiency.

If the work was performed properly, the brake must be efficient.

Front brake calliper

Removal

Remove the front wheel.

Operate the brake lever just beyond the point of closing communication with the tank.

Block the position of the lever by fastening it.



Previously loosen the screw fastening the pipe connector to the calliper.

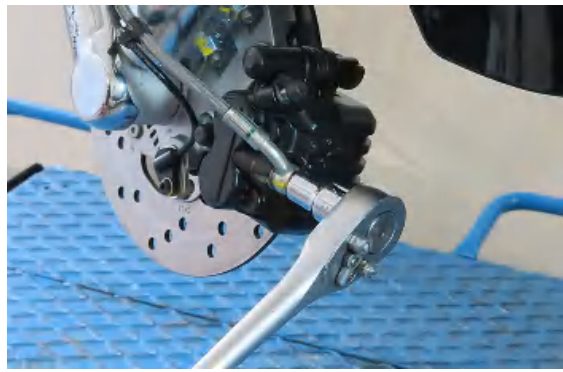

Disconnect the front wheel sensor cable retaining clamps.



Unscrew and remove the front brake calliper fixing screws and remove it from the support.

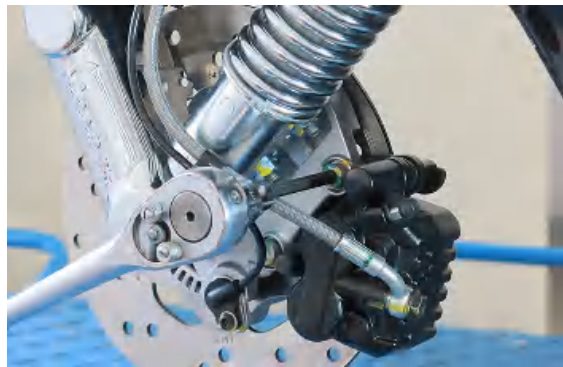

Lift the calliper so that the end part of the pipe is tilted upwards.

Maintaining this position, remove the calliper by acting on the connector with the relative copper washers.



Refitting

Without lowering the pipe, connect the new calliper using the connector and the new copper washers. Keeping the calliper aligned with the vehicle, temporarily block the connector to maintain a seal.



Fasten or maintain the calliper in the up position and free the pump lever.

WARNING

TO RELEASE THE BRAKE LEVER, CUT THE WIRE OF THE FASTENING IN ORDER TO OPEN THE COMMUNICATION WITH THE TANK. AVOID ANY ADDITIONAL OPERATION OF THE BRAKE LEVER.



Keeping the calliper up, connect the drain pipe and open the bleed valve connector.

Allow the air to flow out until only brake fluid exits.

CAUTION

THIS BLEEDING PHASE MUST TAKE PLACE BY MEANS OF GRAVITY. DO NOT ACTIVATE THE PUMP LEVER.



Check and if necessary top up the tank level.



Lower the calliper in the driving direction and slightly inclined to the right so the bleed screw is in the highest point of the calliper.

Reopen the bleed valve connector and let the air flow out.

- Close the bleed valve connector when the level of the brake fluid in the drain pipe has risen at least 10 cm without the outflow of air.

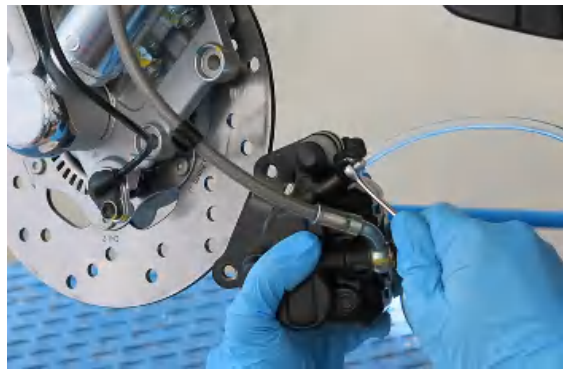

Separate the pads, if necessary, and install the brake calliper on the disc

Fasten the screws fastening the support to the specified torque.

Locking torques (N*m)

front brake calliper shock absorber and brake calliper support 19 - 24 Nm



Loosen the connector fastening the pipe as little as possible to settle the pipe in the neutral position. Finally block the connector to the specified torque.

WARNING

KEEP THE PIPE IN POSITION WHEN TIGHTENING THE CONNECTOR.

Locking torques (N*m)

Calliper - brake calliper connector 20 - 25 Nm

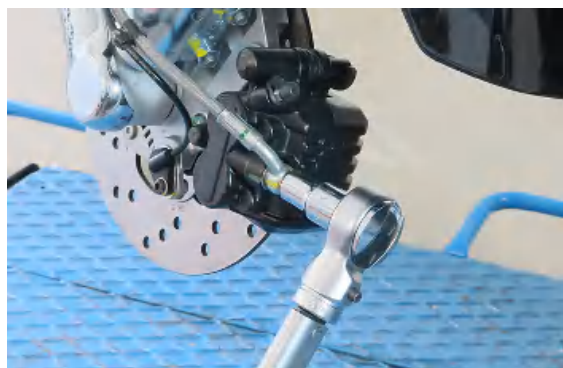

Refill the level of the brake fluid and close the tank cover.

Rear brake disc

Removal

Remove the rear brake calliper.

Remove the tapered spacer.



Remove the rear wheel hub with the brake disc.



Unscrew and remove the screws fastening the brake disc to the rear wheel hub.

Remove the disc.



Refitting

Position the brake disc on the rear wheel hub.

Insert and tighten the fastening screws at the recommended torque.

Locking torques (N*m)

Brake disc - rear wheel hub 11 - 13 Nm



Insert the rear wheel hub with the brake disc on the wheel axle.



Insert the tapered spacer.
Assemble the brake calliper.
Fit the rear wheel.
Assemble the silencer supporting arm.
fit the silencer.



Disc Inspection

Remove the front wheel.
Check the thickness of the disc with an appropriate measuring instrument.

Characteristic

Standard thickness of rear disc

3.90 - 4.20 mm

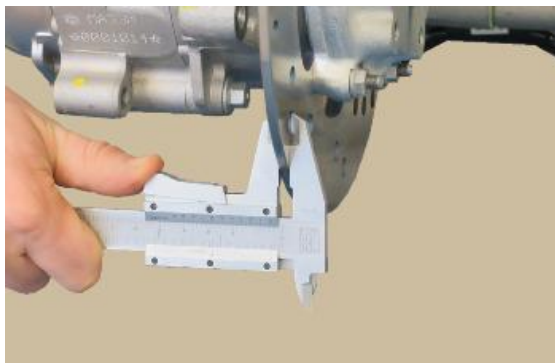

- Repeat the measurement in at least 6 points on the disk.
- Check that the brake disc unit rotates smoothly using a special tool attached to the brake calliper support as shown in the photo.
- In order to secure the appropriate tool adequately use a metal plate with M8 threaded hole and fix it to one of the two rear brake calliper attachment points
- Fix the flange to the wheel axle using the original nut and spacer and an Æ 17mm bearing

N.B.

FOR A CORRECT READING, MAKE THE DRIVEN PULLEY AXLE ROTATE IN ORDER TO ROTATE THE DISC.

Specific tooling

020335Y Magnetic mounting for dial gauge

Characteristic

Max. deviation allowed:

0.1 mm

- If incorrect values are measured, replace the disc. If the anomaly persists, replace the hub.

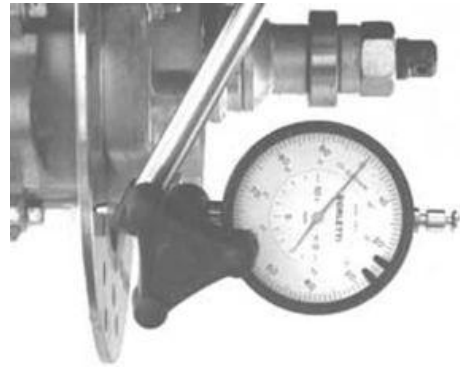

Front brake disc

Removal

- Remove the front wheel.
- Remove the front brake calliper.
- Remove the front wheel hub with the disc.

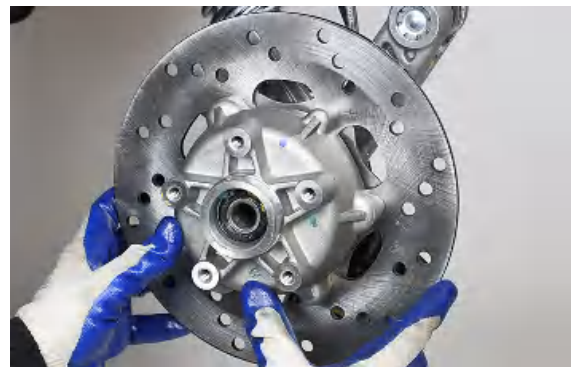

- Unscrew the screws fastening the brake disc and the phonic wheel to the hub and remove them.



Refitting

Fit the brake disc and tone wheel on the hub.
Insert and tighten the fastening screws at the recommended torque.

Locking torques (N*m)

Brake disc - front wheel hub 8 - 10 Nm



Insert the front wheel hub with the brake disc on the wheel axle.

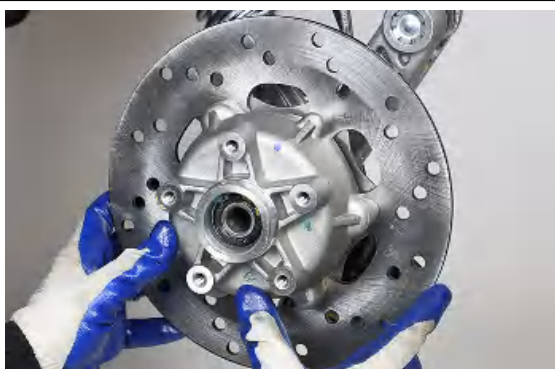

Disc Inspection

Remove the front wheel.
Check the thickness of the disc with an appropriate measuring instrument.

Characteristic

Standard thickness of rear disc

3.90 - 4.20 mm



- Repeat the measurement in at least 6 points on the disk.
- Check that the brake disc unit rotates smoothly using a special tool attached to the brake calliper support as shown in the photo.
- In order to secure the appropriate tool adequately use a metal plate with M8 threaded hole and fix it to one of the two rear brake calliper attachment points
- Fix the flange to the wheel axle using the original nut and spacer and an $\text{Æ} 17\text{mm}$ bearing

N.B.

FOR A CORRECT READING, MAKE THE DRIVEN PULLEY AXLE ROTATE IN ORDER TO ROTATE THE DISC.

Specific tooling

020335Y Magnetic mounting for dial gauge**Characteristic****Max. deviation allowed:**

0.1 mm

- If incorrect values are measured, replace the disc. If the anomaly persists, replace the hub.

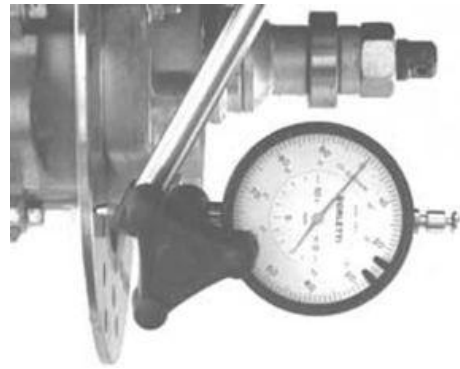
**Front brake pads****Removal**

Rest the vehicle on its centre stand.

Suitably secure the rear part of the vehicle by raising the front slightly.

Remove the front wheel.

Loosen, without removing, the screws fixing the front brake pads.

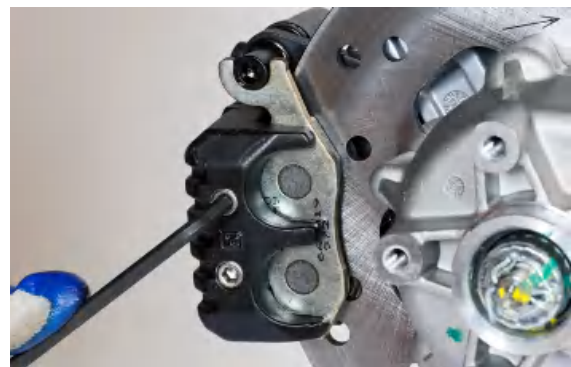

Disconnect the wiring of the tone wheel sensor from the clamp, unscrew the screws fixing the front brake calliper to the support bracket and remove it.



Completely unscrew the screws and remove them, keeping the brake pads in position.



Remove the brake pads.

CAUTION



BE EXTREMELY CAREFUL NOT TO PULL THE BRAKE LEVER AFTER REMOVING THE PADS. THIS OPERATION COULD CAUSE THE CYLINDERS TO EXIT THE BRAKE CALLIPER AS WELL AS THE BRAKE FLUID TO ESCAPE.



- Check the thickness of the wear material and, if below the minimum value, replace the pads.

Characteristic

Friction material minimum permissible thickness

1.5 mm

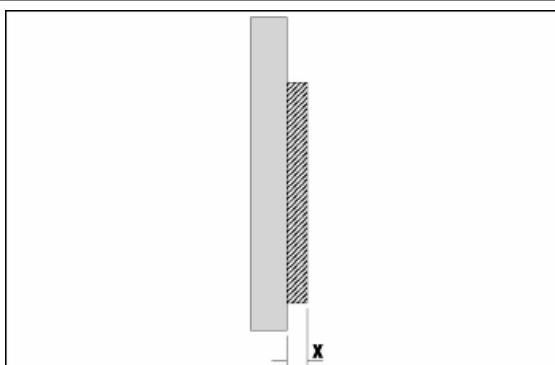

- Also check that the wear of the friction material is uniform and make sure it does not exceed the indicated tolerance. Otherwise, replace the pads.

Characteristic

Maximum permissible thickness tolerance for wear material

0.5 mm

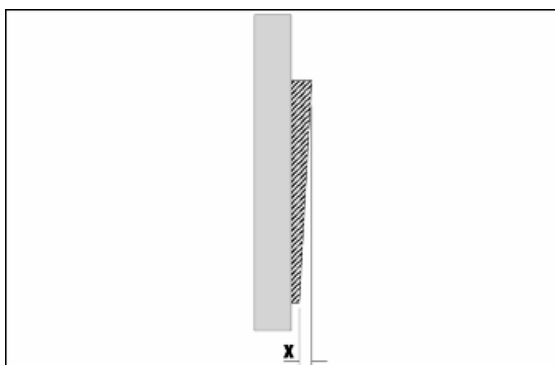

Refitting

Put the new brake pads inside the clamp.



Screw in the fastening screws of the brake pads on the clamp.



Put the brake calliper on the support bracket and tighten the fixing screws to the specified torque. Put the wiring harness of the tone wheel sensor in its clamp.



Locking torques (N*m)

Front brake calliper - Bracket 19 - 24 Nm

Tighten the fixing screws of the brake pads to the clamp at the specified torque.

Fit the front wheel.

Locking torques (N*m)

Front brake pad - Front brake calliper 8 - 10 Nm



Rear brake pads

Removal

- Rest the vehicle on its centre stand.
- Remove the complete silencer.
- Remove the silencer support bracket.
- Remove the rear wheel.
- Unscrew the screws fixing the rear brake calliper to the engine and remove it.

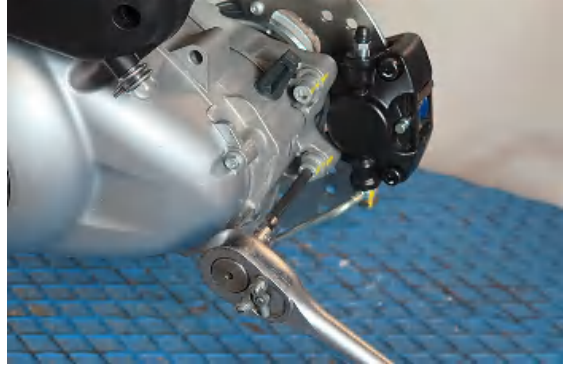

- Remove the stop spring from the fastening pin of the brake pads.



- Extract the fastening pin of the brake pads.



- Remove the compression spring.



Take the brake pads out of the rear brake calliper.

CAUTION



BE EXTREMELY CAREFUL NOT TO PULL THE BRAKE LEVER AFTER REMOVING THE PADS. THIS OPERATION COULD CAUSE THE CYLINDERS TO EXIT THE BRAKE CALLIPER AS WELL AS THE BRAKE FLUID TO ESCAPE.



- Check the thickness of the wear material and, if below the minimum value, replace the pads.

Characteristic

Friction material minimum permissible thickness

1.5 mm

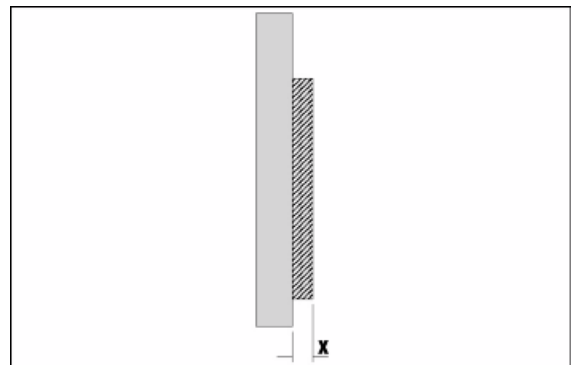

- Also check that the wear of the friction material is uniform and make sure it does not exceed the indicated tolerance. Otherwise, replace the pads.

Characteristic

Maximum permissible thickness tolerance for wear material

0.5 mm

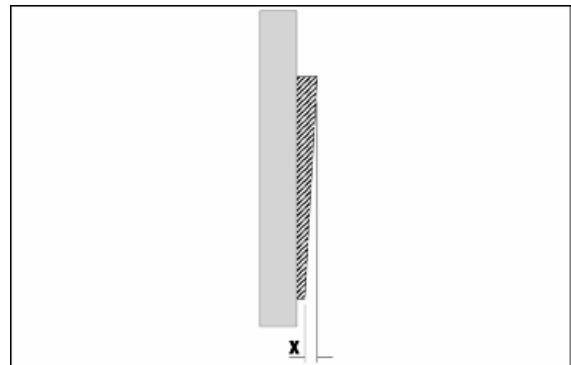

Refitting

Put the new brake pads inside the clamp.



Put the compression spring back inside the brake calliper.



Insert the fastening pin of the brake pads.



Insert the stop spring on the fastening pin of the brake pads.



Put back the brake calliper in its seat and tighten the fixing screws to the specified torque.

Refit the rear wheel.

Refit the silencer support bracket.

Refit the complete silencer.

Locking torques (N*m)

Rear brake calliper - Engine 20 - 25 Nm



Fill

Rear - combined

For this procedure, see section «Misc. documents».

Front

For this procedure, see section «Misc. documents».

Brake fluid level check

Rest the vehicle on its centre stand and with the handlebars perfectly horizontal.

Check the liquid level through the relative inspection sight glass.

If the sight glass is full, the brake fluid level is correct. If the brake fluid is near the «MIN» reference, top-up



Front brake pump

Removal

Remove the handlebar covers.

Remove the front wheel.

Disconnect the stop light switch connectors.



Disconnect the front wheel sensor cable retaining clamps.



Unscrew and remove the front brake calliper fixing screws and remove it from the support.

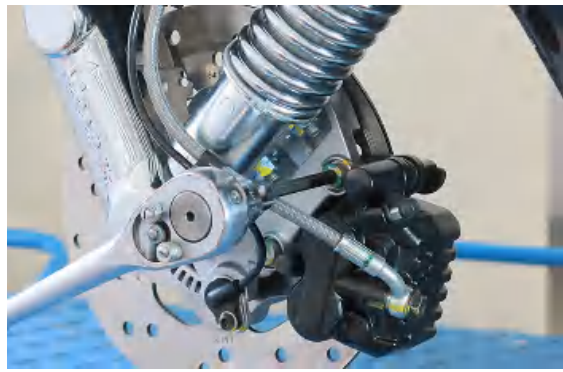

With new pads or pads in a good condition, operate the brake pump repeatedly to bring the pads in contact with each other.



Previously loosen the brake pump connector.



Unscrew the screws of the U-bolt fastening the pump.



Position the pump as shown in the photo and remove the connector with the copper washers.



Suitably protect the connector and secure it so it is tilted upward to keep air from entering.



Immediately proceed with installing the new brake pump.

CAUTION



BRAKE FLUID IS HYGROSCOPIC; THAT IS, IT ABSORBS MOISTURE FROM THE AIR. IT IS IMPORTANT TO COMPLETE THESE OPERATIONS AS QUICKLY AS POSSIBLE TO AVOID THE DEGRADATION OF THE CHARACTERISTICS OF THE FLUID.

Refitting

Install the new pump on the handlebars, paying attention to the correct position of the U-bolt.

Block the screws temporarily.



Remove the tank cover and tighten the pipe fastening connector to the specified torque using new copper washers.

Locking torques (N*m)

Pump connector - Brake pump 20 - 25 Nm



Position the handlebars so that the pump tank is levelled horizontally.

Top up with DOT4 brake fluid to the maximum level.

Recommended products

DOT 4 brake fluid Synthetic brake fluid.

SAE J 1703; FMVSS 116; ISO 4925; CUNA NC 956 DOT4



Operate the brake pump lever repeatedly, making the air bubble in the tank.

CAUTION

PERFORM THE OPERATION WITH THE HANDLEBARS TURNED IN THE MAXIMUM POSITION AWAY FROM THE BRAKE PUMP.



When the air finished bubbling in the tank, move the pads away in order to send the brake fluid to the pump.

During this operation, there will be a backflow of air in the tank.

Operate the pump lever until the pads are in contact with each other and repeat the procedure until the air stops exiting.



Refit the calliper on the support and tighten the screws to the specified torque.

Locking torques (N*m)

Front brake calliper - Bracket 19 - 24 Nm



Restore the working distance of the pads and top up the brake fluid level to the maximum.



Close the pump cover and remove the screws with the U-bolt fastened to the handlebars.



Lift the pump so it is upright and repeatedly operate the control lever.

This operation is required so the residual air contained in the pump cylinder will exit.

For an optimal result, slightly vary the position of the pump each time the lever is operated.

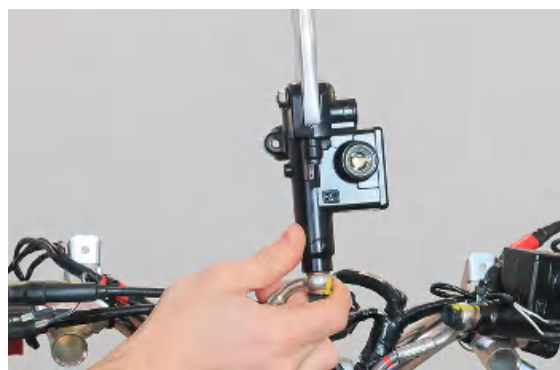

Install the pump on the handlebars, paying attention to the correct orientation of the U-bolt.
Gradually tighten the fastening screws to the specified torque.

Locking torques (N*m)

U-bolt - Brake pump 7 - 10 Nm.

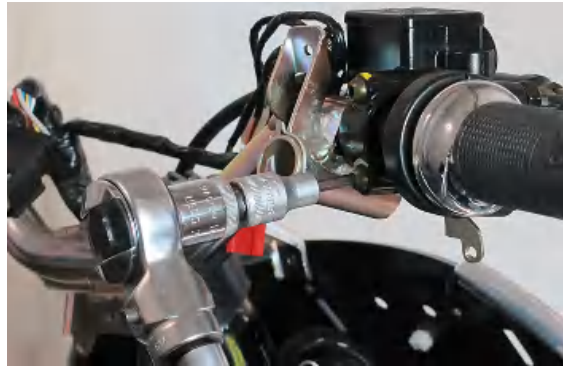

Connect the stop light switch connector.

**Rear brake pump - combined****Removal**

Remove the handlebar covers.

Remove the rear wheel.

Disconnect the stop light switch cables.



Unscrew the screw on the clamp fastening the rear brake hose to the engine.



Undo the fixing screws of the rear brake calliper to the engine.



With new pads or pads in a good condition, operate the brake pump repeatedly to bring the pads in contact with each other.

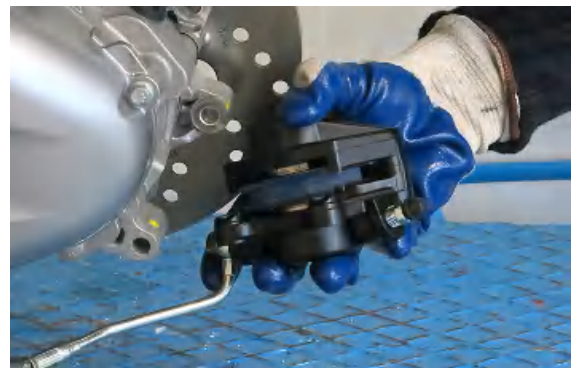

Previously loosen the brake pump connector.



Unscrew the screws of the U-bolt fastening the pump.



Disconnect the pump from the handlebar, position it as shown in the photo and remove the connector with the copper washers.



Suitably protect the connector and secure it so it is tilted upward to keep air from entering.



Immediately proceed with installing the new brake pump.

CAUTION

BRAKE FLUID IS HYGROSCOPIC; THAT IS, IT ABSORBS MOISTURE FROM THE AIR. IT IS IMPORTANT TO COMPLETE THESE OPERATIONS AS QUICKLY AS POSSIBLE TO AVOID THE DEGRADATION OF THE CHARACTERISTICS OF THE FLUID.

Refitting

Install the new pump on the handlebars, paying attention to the correct position of the U-bolt.
Block the screws temporarily.



Remove the tank cover and tighten the pipe fastening connector to the specified torque using new copper washers.

Locking torques (N*m)

Pump connector - Brake pump 20 - 25 Nm



Position the handlebars so that the pump tank is levelled horizontally.

Top up with DOT4 brake fluid to the maximum level.

Recommended products

DOT 4 brake fluid Synthetic brake fluid.

SAE J 1703; FMVSS 116; ISO 4925; CUNA NC 956 DOT4



Operate the brake pump lever repeatedly, making the air bubble in the tank.

CAUTION

PERFORM THE OPERATION WITH THE HANDLEBARS TURNED IN THE MAXIMUM POSITION AWAY FROM THE BRAKE PUMP.



When the air finished bubbling in the tank, move the pads away in order to send the brake fluid to the pump.

During this operation, there will be a backflow of air in the tank.

Operate the pump until the pads are in contact with each other and repeat the procedure until the air stops exiting.



Refit the calliper on the engine and tighten the screws to the specified torque.

Locking torques (N*m)

Rear brake calliper screws - Engine 20 - 25 Nm



Restore the working distance of the pads and top up the brake fluid level to the maximum.



Close the pump cover and remove the screws with the U-bolt fastened to the handlebars.



Lift the pump so it is upright and repeatedly operate the control lever.

This operation is required so the residual air contained in the pump cylinder will exit.

For an optimal result, slightly vary the position of the pump each time the lever is operated.



Install the pump on the handlebars, paying attention to the correct orientation of the U-bolt.
Tighten the fastening screws to the prescribed torque.

Locking torques (N*m)

U-bolt - Brake pump 7 - 10 Nm



Connect the stop light switch connectors.



INDEX OF TOPICS

COOLING SYSTEM

COOL SYS

COOLING

Name	Torque in Nm
Water pump rotor cover	3 - 4
Thermostat cover screws	3 - 4
Bleeder screw	3

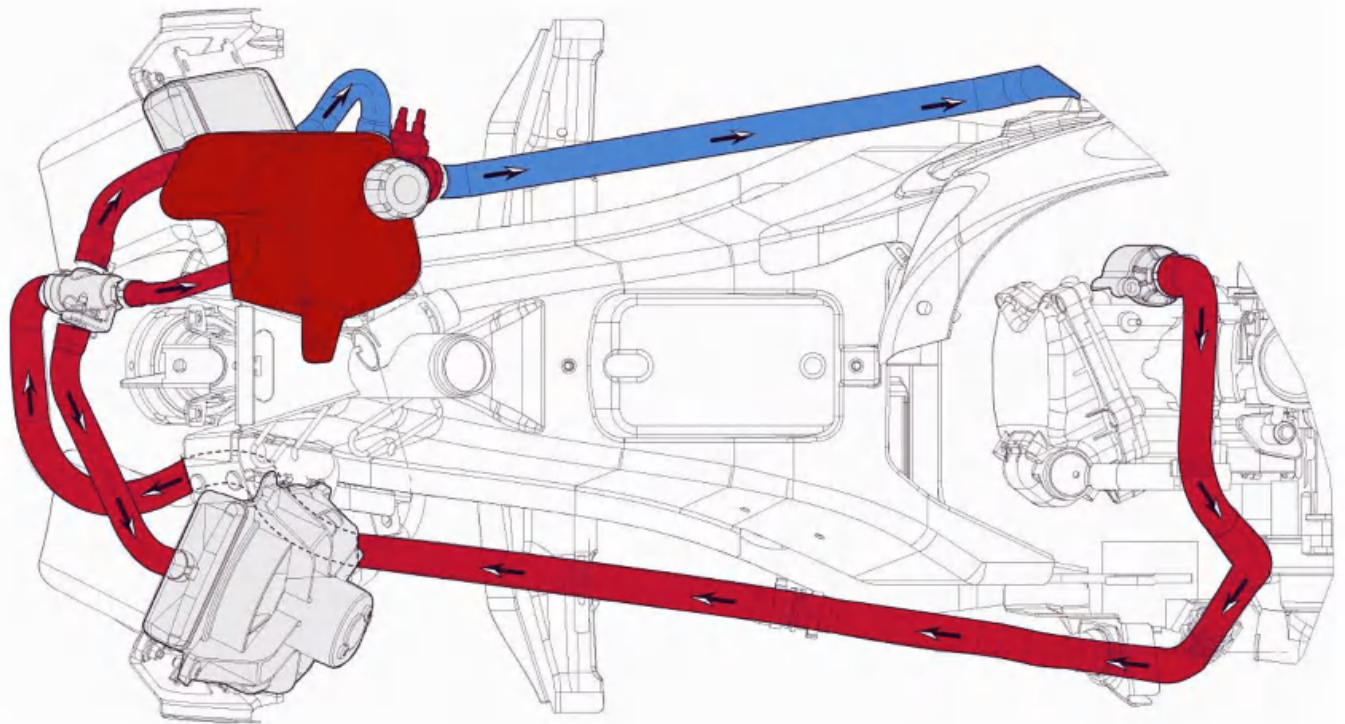
Circuit diagram

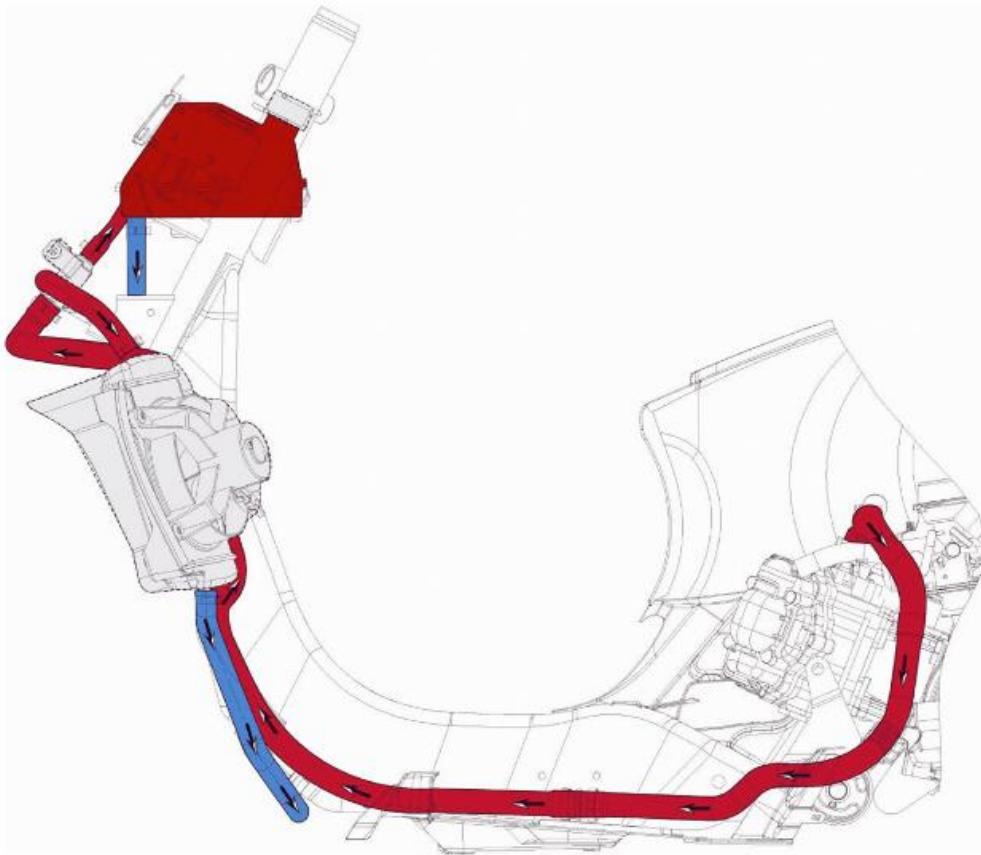

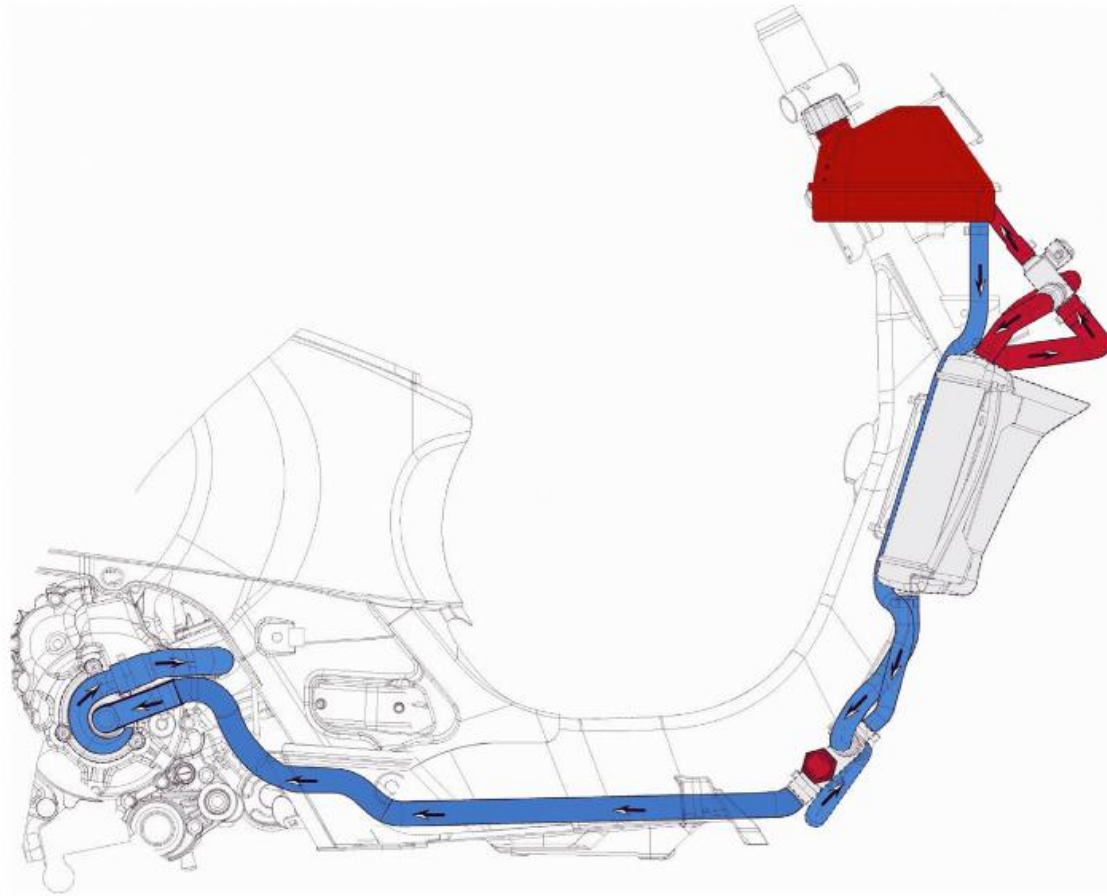

System bleed

WARNING

NEVER UNSCREW THE EXPANSION TANK CAP BEFORE THE COOLING SYSTEM HAS COOLED.

Remove the expansion tank cover at the top right on the shield.

Fill the cooling system until reaching the "MAX" level of the expansion tank.

Recommended products

Anti-freeze liquid, ready to use, colour red Ethylene glycol antifreeze liquid with organic inhibition additives. Red, ready to use.

ASTM D 3306 - ASTM D 4656 - ASTM D 4985 -
CUNA NC 956-16



- Loosen the bleed screw on the big end.
- Add more coolant in the expansion tank until the coolant overflows from the bleeder hole.
- Tighten the bleed screw.

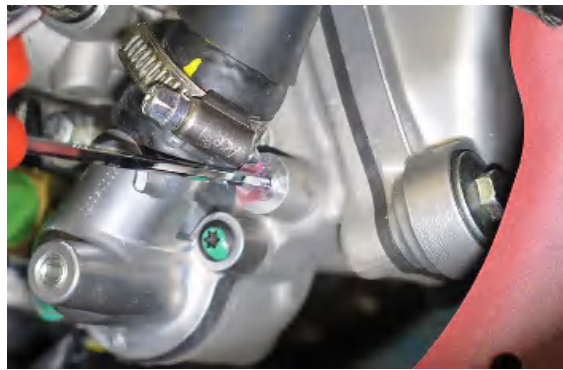

- Loosen the bleed screw situated at the top of the thermostat cover .
- Add more coolant in the expansion tank until the coolant overflows from the bleeder hole.
- Tighten the bleed screw.



Restore the "**MAX**" level of the expansion tank.



Tighten with force the expansion tank cap.

WARNING

NEVER UNSCREW THE EXPANSION TANK CAP BEFORE THE COOLING SYSTEM HAS COOLED.



Start the engine at idle speed.

CAUTION



NEVER UNSCREW THE COOLING SYSTEM BLEED SCREW WITH THE ENGINE RUNNING OR HOT.

With the engine idling, place a hand close to the water outlet hose from the engine.



The opening of the thermostat is confirmed as soon as a sudden rise in the temperature of the circulating liquid in the hose is detected.

With the thermostat open, slowly rotate the accelerator handle.

Take the engine to medium revs and maintain it for about 10 seconds.



Return the engine to idle and wait for the electric fan to start.

Wait for the electric fan to stop and turn off the engine.

CAUTION



NEVER UNSCREW THE COOLING SYSTEM BLEED SCREW WITH THE ENGINE RUNNING OR HOT.

WARNING

NEVER UNSCREW THE EXPANSION TANK CAP BEFORE THE COOLING SYSTEM HAS COOLED.

Wait for the complete cooling of the system and restore the "MAX" level of the coolant



Thermostat

Removal

To remove the thermostat, proceed as follows:

- Remove the helmet compartment.
- Place a + 2.0 l container under the vehicle to collect the coolant.
- Unscrew and remove the cover fastening screws



- Lift and remove the thermostat cover.

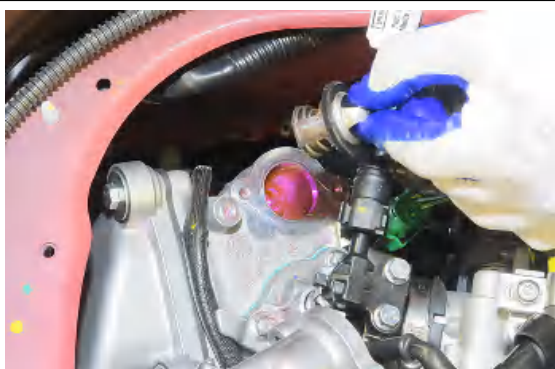

Check

- 1) Visually inspect that the thermostat is not damaged.
- 2) Fill a metal container with approx. 1 litre of water.

Immerse the thermostat, and keep it in the centre of the container.

Immerse the multimeter temperature probe, and keep it close to the thermostat.

Heat up the container using the thermal gun.

Check the temperature at which the thermostat starts to open:

Heat up until the thermostat is completely open

- 3) Replace the thermostat if it is not working properly.



CAUTION

TO EXECUTE THE TEST CORRECTLY, MAKE SURE NEITHER THE THERMOSTAT NOR THE THERMOMETER TOUCHES THE CONTAINER.

Specific tooling

020331Y Digital multimeter

020151Y Air heater

THERMOSTAT

Specification	Desc./Quantity
Type	Wax-type, with deviator
Starts opening at	85±2°C

Refitting

- Insert the thermostat in the head.
- Position the cover.



- Insert the cover fixing screws and tighten them to the specified torque.
- Fill the system and bleed it.



Locking torques (N*m)

Thermostat cover screws 3 - 4

INDEX OF TOPICS

CHASSIS

CHAS

This section è is dedicated to the operations that can be carried out on the vehicle's bodywork.

Seat

REMOVAL

Remove the helmet compartment.
Support the saddle, undo and remove the saddle fixing screws.
Remove the saddle.



FITTING

Position the saddle
Support the saddle, insert and tighten the saddle fixing screws.
Insert the helmet compartment.



SADDLE OPENING DEVICE REMOVAL

Remove the helmet compartment.



Remove the plastic cover above the luggage rack.



Free the electrical wiring from the retaining ties.



Disconnect the cable from the saddle's lock.



Unscrew and remove the fastening nuts from the saddle opening device's bracket.



Move the saddle opening device complete with the bracket downward and disconnect the electrical connector.



Unscrew and remove the bolts fastening the device to the bracket.

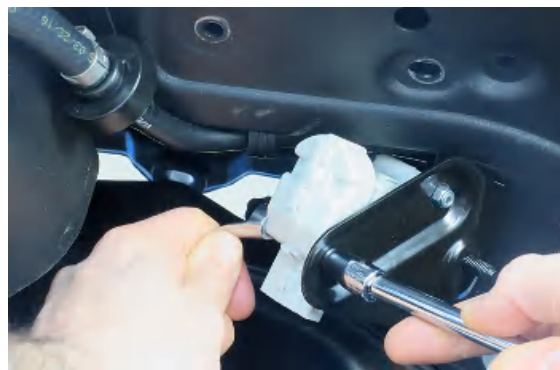

Disconnect the device from the spring.



SADDLE OPENING DEVICE ASSEMBLY

Connect the device to the spring.



Insert and tighten the bolts for fastening the device to the bracket.

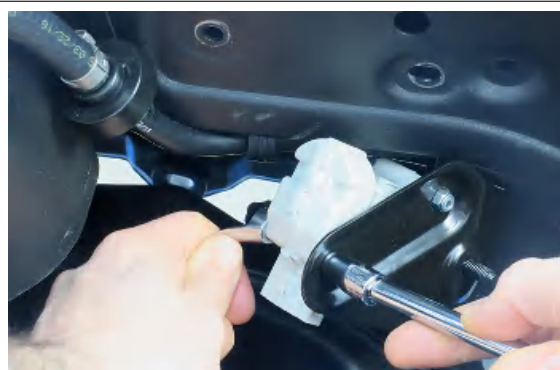

Connect the device's electrical connector and insert the saddle opening device complete with the bracket into its lodging.



Connect the cable to the saddle's lock.



Apply and tighten the nuts for fastening the saddle opening device's bracket.



Insert the electrical wiring into the retaining ties.

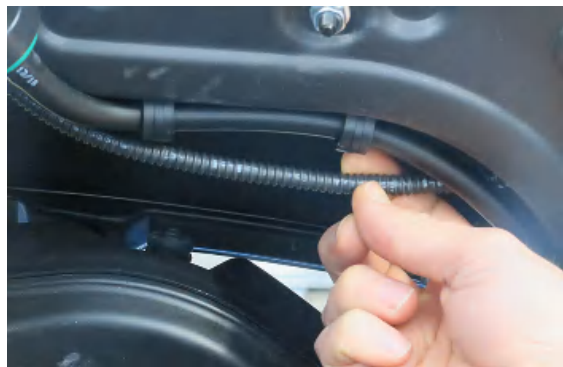

Mount the plastic cover above the luggage rack.
Insert the helmet compartment.



Rear rack

REMOVAL

Remove the helmet compartment.
Undo and remove the fixing screws of the luggage rack and the plastic cover.



Remove the fuel tank cap.



Remove the plastic cover.



Unscrew and remove the fixing screw of the luggage rack screws cover.
Remove the cover of the rear screws of the luggage rack.



Unscrew and remove the rear fixing screws of the luggage rack.
Remove the luggage rack.



FITTING

Position the luggage rack.
Insert and tighten the rear fixing screws of the luggage rack.



Position the cover of the rear screws of the luggage rack.
Insert and tighten the fixing screw of the luggage rack screws cover.



Position the plastic cover.



Screw on the fuel tank cap.



Insert and tighten the fastening screws for the luggage rack and the plastic cover.
Insert the helmet compartment.



Driving mirrors

REMOVAL

Rest the vehicle on its centre stand.

Move the protection rubber.



Unscrew the fixing counter nut and unscrew the mirror using the rod.



FITTING

Screw the mirror into its seat using the rod.
Tighten the fixing counter nut to the specified torque.

Locking torques (N*m)

Rear-view mirror - Handlebars 15 - 20 Nm



Put back protection rubber.



Rear handlebar cover

REMOVAL

Rest the vehicle on its centre stand.
Remove the rear-view mirrors.
Remove the front centre cover.
Remove the front handlebar cover.
Unscrew from both sides the top fixing screw of the rear cover.



Unscrew from both sides the bottom fixing screw of the rear cover.



Remove the rear cover from the handlebars and disconnect the connector of the instrument unit.

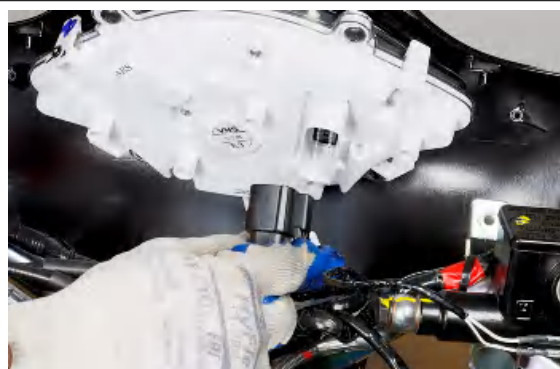

Disconnect the connectors of the left control unit.



Disconnect the connectors of the right control unit and remove the rear cover.



FITTING

Connect the connectors of the right control unit.



Connect the connectors of the left control unit.



Connect the connector of the instrument unit.

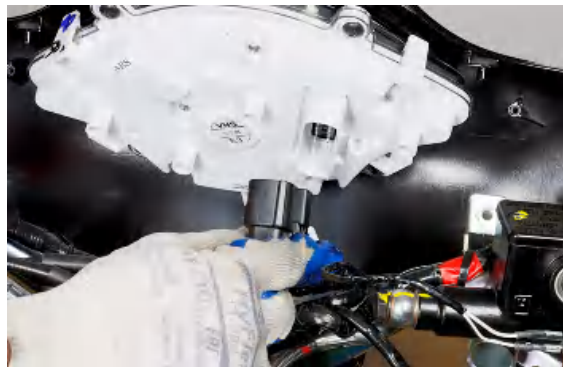

Place the rear handlebar cover in its seat making sure the cables and tubes pass through correctly. Tighten the bottom screws fixing the cover to the handlebars to the specified torque.

Locking torques (N*m)

Rear handlebar cover - handlebars 1 - 1.7 Nm



Tighten the top screws fixing the cover to the handlebars to the specified torque.

Refit the front handlebar cover.

Refit the front centre cover.

Refit the rear-view mirrors.

Locking torques (N*m)

Rear handlebar cover - handlebars 1 - 1.7 Nm



Instrument panel

REMOVAL

Remove the rear handlebar cover.

Remove the four fixing screws.

Remove the instrument panel.

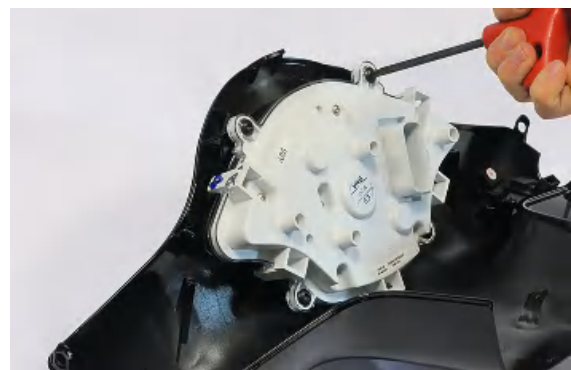

FITTING

Position the instrument panel in its seat.

Insert and tighten the fixing screws.

Refit the rear handlebar cover.

Front handlebar cover

REMOVAL

Rest the vehicle on its centre stand.

Remove the rear-view mirrors.

Remove the front centre cover.

Unscrew the central screw fixing the cover to the handlebars.



Unscrew from both sides the bottom screw fixing the front cover to the rear cover.



Separate the front cover from the rear cover by releasing the side retainers.



Disconnect the connector of the front light assembly and remove the front handlebar cover.



FITTING

bring up the handlebar front cover and connect the connector of the front light assembly.



Join the front cover to the rear cover by engaging the side retainers.

Tighten the bottom screws fixing the front cover to the rear cover to the specified torque.

Locking torques (N*m)

Front handlebar cover - Rear handlebar cover
1 - 1.7 Nm



Tighten the middle screw fixing the front cover to the handlebars to the specified torque.

Refit the front centre cover.

Refit the rear-view mirrors.

Locking torques (N*m)

Front handlebar cover - Handlebar 1 - 1.7 Nm



Headlight assy.

Remove the front handlebar cover.

Unscrew the fixing screws of the front light assembly.



- Remove the light unit, detaching it from the front of the handlebar cover.



Unscrew the fixing screw and remove the turn indicator.



Frame central cover

Rest the vehicle on its centre stand.

Unscrew the screws fixing the middle cover to the footrest and remove it.

When refitting, tighten the fixing screws to the specified torque.

Locking torques (N*m)

Chassis middle cover - Footrest 1 - 1.7 Nm



Knee-guard

REMOVAL

Remove the handlebar covers.

Remove the front centre cover.

Remove the expansion tank cover and the left side cover by unscrewing the fixing screws.



Undo and remove the screws under the expansion tank cover and under the left side cover.



Unscrew and remove the screws on the shield.



Unscrew and remove the screws near the footrest.



Unscrew and remove the central screw inside the glove box.



Detach the leg shield back plate from the body.
Disconnect the connector for the USB port and the connector for the saddle opening button.
Disconnect the fuse terminal block from the leg shield back plate.
disconnect the emergency saddle opening transmission.
The leg shield back plate is now free and can be removed.



FITTING

Position the leg shield back plate on the body.
Connect the emergency saddle opening transmission.

Insert the fuse terminal block into its lodging inside the leg shield back plate.

Connect the connector for the USB port and the connector for the saddle opening button.

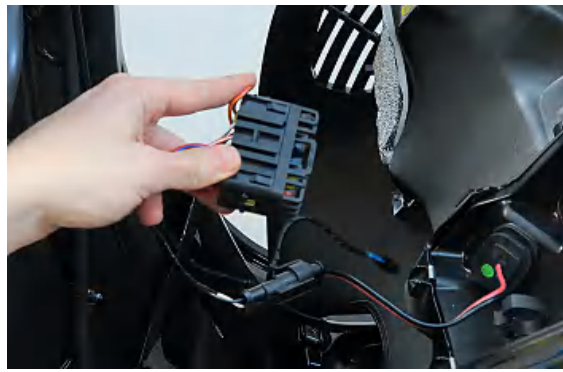

Insert and tighten the central screw inside the glove box.



Insert and tighten the screws under the expansion tank cover and under the left side cover.



insert and tighten the screws near the footrest.



insert and tighten the screws on the shield.



Assemble the expansion tank cover and the left side cover.

Insert and tighten the fixing screws.

Assemble the front centre cover.

Fit the handlebar covers.



Taillight assy.

REMOVAL

To remove the rear light assembly, unscrew and remove the fastening screw.



Disconnect the connector.



FITTING

Support the light assembly and connect the connector.



Insert the light assembly into its lodging.
Insert and tighten the fastening screw.

**REMOVAL**

To remove the rear turn signal device, unscrew and remove the fastening screw.



Remove the turn signal device, support it, and disconnect the connector.

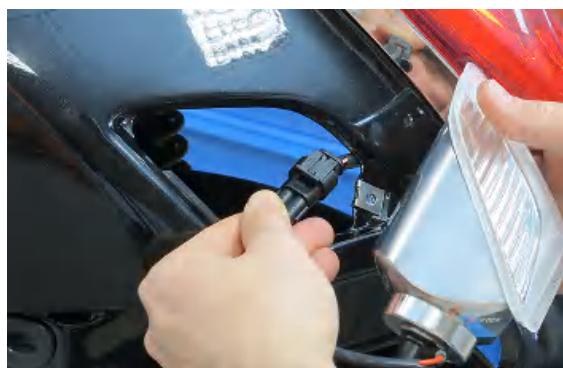

FITTING

Connect the connector and insert the turn signal device into its lodging.



Insert and tighten the fastening screw.



Footrest

REMOVAL

Remove the leg shield back plate.
Remove the battery compartment cover and the battery.
Remove the side fairings
Remove the centre screw under the battery compartment cover.



Unscrew and remove the fixing screws of the passenger footrests.
Remove the footrests.



Remove the left and right footrest fixing screw.

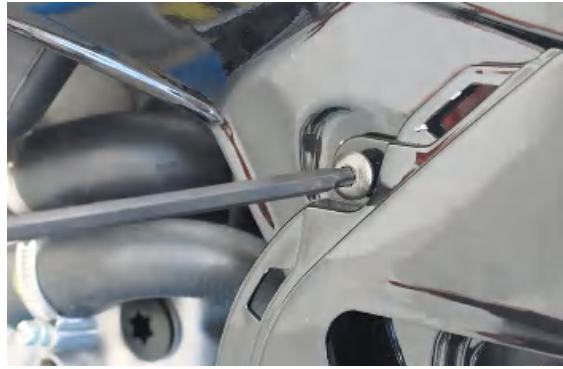

Remove the left and right lower cover fixing screws.

Remove the lower covers.



Remove the non-slip rubber strips of the footrest.



Remove the screws positioned under the non-slip rubber strip.

Remove the footrest



FITTING

position the footrest on the frame.
Insert and tighten the screws positioned under the non-slip rubber strip.



Insert the central screw.



Insert and tighten the left and right footrest fixing screw.

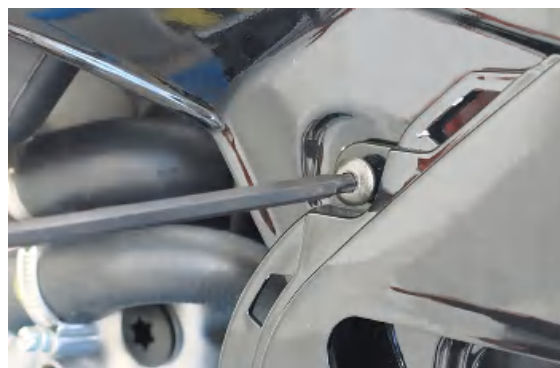

assemble the lower covers.
Insert and tighten the left and right lower cover fixing screws.



Assemble the passenger footrests
Insert and tighten the footrest fixing screws.



Insert the non-slip rubber strips on the footrest.
Assemble the side fairings
Assemble the battery compartment cover and the battery.
Assemble the leg shield back plate.



Side fairings

REMOVAL

Proceed as follows to remove the side fairings:
- Undo and remove the front fastener screw.



- Undo and remove the rear fastener screw.



-
- Undo and remove the fastener nut under the bodywork.



-
- remove the side fairing, pulling outwards.



FITTING

- Fit the side fairing on the vehicle, fitting the pins into the rubber bushes.



-
- Fit and tighten the fastener nut under the bodywork.



- Fit and tighten the rear fastener screw.



- Fit and tighten the front fastener screw.

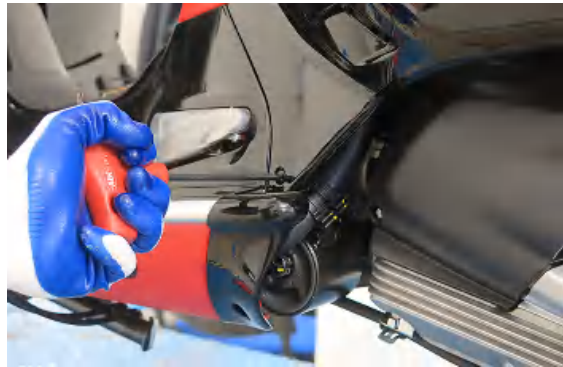

Helmet bay

- Rest the vehicle on its centre stand.
- Lift the saddle and remove the helmet compartment by lifting it up.



Fuel tank

REMOVAL

- Support the vehicle adequately.
- insert a suitable lifting device beneath the body.
- Remove the helmet compartment.
- Remove the side fairings.
- remove the silencer.



Secure the rear of the vehicle with a suitable hoist.



Remove the plastic cover above the luggage rack.
Remove the rear light assembly and the right rear turn signal device.



Disconnect the rear shock absorbers' lower attachments.



Using the hoist, lift the vehicle to increase the space between the body and the engine.

CAUTION

MAKE SURE THAT THE ELECTRIC CABLES AND PIPES ARE NOT SUBJECTED TO EXCESSIVE TENSION WHEN USING THE HOIST.

Undo and remove the fixing screw of the fuel delivery hose to the injector



Disconnect the fuel pipe fitting.



Unscrew and remove the fuel pipe clamp fastening nut.



Remove the clamp and disconnect the pipe at the mouth of the tank.



Unscrew and remove the tank's front fastening screw.



Unscrew and remove the rear fastening screw underneath the rear light assembly's chrome-plated frame.



Support the tank.

unscrew and remove the tank fastening screw near the right rear shock absorber's attachment. remove the tank by disconnecting the connectors for the fuel pump and the fuel level indicator.



FITTING

Connect the connectors for the fuel pump and the fuel level indicator, and insert the tank into its lodging.

Insert and tighten the tank fastening screw near the right rear shock absorber's attachment.



Insert and tighten the tank's rear fastening screw near the rear light assembly's lodging.



Insert and tighten the tank's front fastening screw.



Position the fuel pipe clamp.
Insert and tighten the fixing nut



Connect the fuel pipe fitting.



Insert and tighten the clamp fixing screw of the fuel delivery hose to the injector



Using the hoist, lower the vehicle's body so that the rear shock absorbers' attachments are aligned.

Connect the rear shock absorbers.



Lower the vehicle using the hoist.

Remove the lifting device from underneath the body.

fit the silencer.

Mount the rear light assembly and the right rear turn signal device.

connect the pipe at the mouth of the fuel tank and secure it with a new metallic clamp.

Mount the plastic cover on the luggage rack

Mount the side fairings.

Insert the helmet compartment.

Front mudguard

REMOVAL

Suitably support the vehicle so the front wheel is lifted from the ground.

Remove the front wheel.

Remove the front brake calliper.



Remove the steering tube



Unscrew and remove the front mudguard fixing screws.

Slide off the mudguard from the steering tube.



FITTING

Insert the mudguard on the steering tube.

insert the front mudguard fastening screws and tighten to the specified torque.

Locking torques (N*m)

Front mudguard - Steering tube 5 - 6.5 Nm



Insert the steering tube.



Reassemble the front brake calliper and bleed the system.

Fit the front wheel.



Radiator fan

REMOVAL

- In order to carry out any operation on the radiator unit, flow out the coolant in the coolant delivery pipe in the pump.



Remove the leg shield back plate.
Remove the cooling hoses plastic retaining clamps.



Unscrew and remove the nuts and screw fastening the right radiator.



Disconnect the electric fan connector.



Unscrew and remove the electric fan fixing screws to the left radiator.

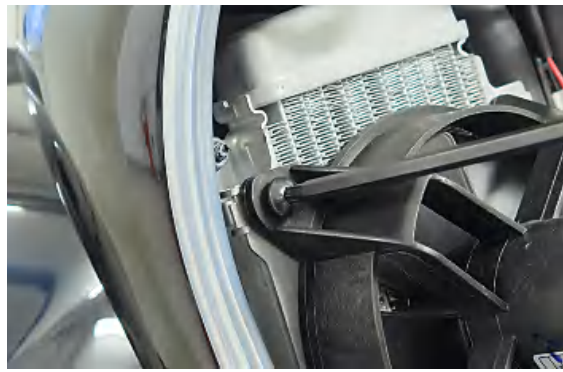

Remove the electric fan.



Remove the hose from its seat.

Unscrew and remove the nuts and screw fastening the left radiator.

Remove the clamps of the connection hoses to the right and left radiators.

Remove the radiators.

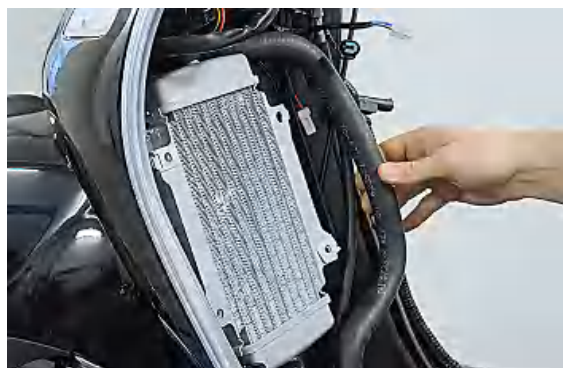

FITTING

Position the radiators in their seats.

Insert the fluid inlet and outlet hoses to the radiators.

Fasten the connection hoses to the right and left radiators with new clamps.

Insert the hose in its seat.

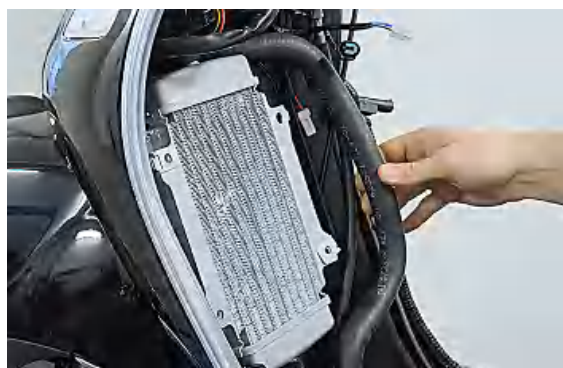

Position the electric fan in its housing on the left radiator.



Connect the electric fan connector.



Insert and tighten the electric fan fixing screws to the left radiator.

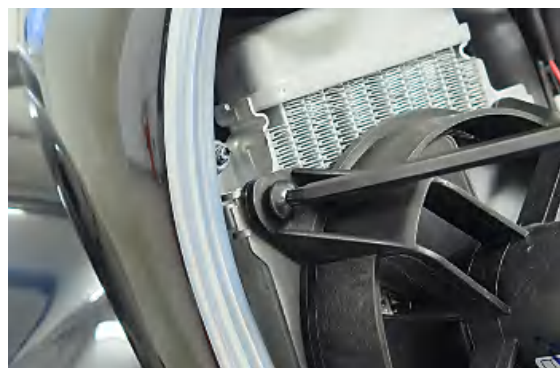

Insert and tighten the nuts and screw fastening the right radiator.



Insert the new cooling hoses plastic retaining clamps.

Reassemble the leg shield back plate.



Fasten the fluid inlet hose to the pump.

Fill the system.



Front central cover

REMOVAL

Rest the vehicle on its centre stand.

Using a flat-head screwdriver, remove the clip-on badge.



Unscrew the screw fixing the central cover to the frame.



Pull the cover to remove it.



FITTING

Place the central cover in its seat.

Push the cover towards the leg shield to ensure that all the spring clips engage correctly.



Tighten the screw fixing the central cover to the chassis at the specified torque.

Put back the clip-on badge.

Locking torques (N*m)

Front central cover - Frame 4.5 - 7 Nm



Battery

REMOVAL

Rest the vehicle on its centre stand.

Remove the chassis central cover.

Unscrew the fixing screws of the battery bracket.



Remove the battery bracket.



Unscrew the fixing screw of the negative pole «-» and disconnect it.



Unscrew the fixing screw of the positive pole «+» and disconnect it.

CAUTION



IT IS EXTREMELY IMPORTANT TO OBSERVE THE INDICATED DISCONNECTION SEQUENCE OF THE CABLES TO AVOID SHORT-CIRCUITS.



Remove the battery from its housing.



FITTING

Check the state of the battery charge.
 Follow the instructions in this manual.
 Insert the new battery in its seat as shown in the figure.



Characteristic

Battery

12V-10Ah

Screw in the fixing screw of the positive pole «+» to the battery.



Screw in the fixing screw of the negative pole «-» to the battery.



CAUTION



IT IS IMPORTANT TO OBSERVE THE INDICATED CONNECTION SEQUENCE OF THE CABLES TO THE BATTERY TO AVOID SHORT-CIRCUITS. FIRST CONNECT THE POSITIVE CABLE «+» AND THEN THE NEGATIVE CABLE«-».

CAUTION



DO NOT REVERSE THE POLARITY: RISK OF SHORT CIRCUIT AND DAMAGE TO THE ELECTRICAL SYSTEM.

WARNING



USED BATTERIES ARE HARMFUL FOR THE ENVIRONMENT. COLLECTION AND DISPOSAL SHOULD BE CARRIED OUT IN COMPLIANCE WITH REGULATIONS IN FORCE.

Put back the battery bracket and tighten the fixing screws to the specified torque.

Put back the chassis central cover.

Locking torques (N*m)

Battery bracket - Footrest 4.5 - 7 Nm



A

ABS: 320

Air filter: 59

B

Battery: 110, 121, 133, 169, 413

Brake: 341, 345, 348, 351, 353, 355, 359, 364

Brake fluid: 359

Bulbs:

C

Checks: 116

E

Engine oil: 61

F

Fuel: 256, 264, 402

Fuses: 127

H

Headlight: 74, 391

Horn: 124

Hub oil: 58

I

Identification: 18

Instrument panel: 83, 389

M

Maintenance: 17, 52

Mirrors: 385

O

Oil filter: 63

R

Recommended products: 54

S

Shock absorbers: 311

Spark plug: 57

Stand: 318

Start-up: 9

Suspension:

T

Tank: 402

Technical Data: 17

Transmission: 181, 199

Turn indicators: 114

V

Vehicle: 18, 172, 174