



**PIAGGIO**

---

# **MANUALE STAZIONE DI SERVIZIO**

---

**1Q000412**

---



**Liberty ABS 125 i.e. 3V IGET**

---



# MANUALE STAZIONE DI SERVIZIO

## Liberty ABS 125 i.e. 3V IGET

The descriptions and images in this publication are given for illustrative purposes only. While the basic features as described and illustrated in this manual remain unchanged, Piaggio & C. S.p.A. reserves the right, at any time and without being required to update this publication beforehand, to make any changes to components, parts or accessory supplies which it deems necessary to improve the product, or which are required for manufacturing or commercial reasons.

Not all versions/models shown in this publication are available in all countries. Availability of the individual versions must be verified with the official PIAGGIO sales network.

© Copyright 2022 - Piaggio & C. S.p.A. All rights reserved. Reproduction of this publication in whole or in part is prohibited.

Piaggio & C. S.p.A. Viale Rinaldo Piaggio, 25 - 56025 PONTEDERA (PI), Italy

[www.piaggio.com](http://www.piaggio.com)

---

---

# MANUALE STAZIONE DI SERVIZIO

## Liberty ABS 125 i.e. 3V IGET

Questo manuale per stazioni di servizio è stato realizzato da Piaggio & C. Spa per essere utilizzato dalle officine dei concessionari e sub-agenzie Piaggio. Si presuppone che chi utilizza questa pubblicazione per la manutenzione e la riparazione dei veicoli Piaggio, abbia una conoscenza base dei principi della meccanica e dei procedimenti inerenti la tecnica della riparazione dei veicoli. Le variazioni importanti nelle caratteristiche dei veicoli o nelle specifiche operazioni di riparazione verranno comunicate attraverso aggiornamenti di questo manuale. Non si può comunque realizzare un lavoro completamente soddisfacente se non si dispone degli impianti e delle attrezzature necessarie, ed è per questo che vi invitiamo a consultare le pagine di questo manuale riguardanti l'attrezzatura specifica e il catalogo degli attrezzi specifici.

**N.B.** Provides key information to make the procedure easier to understand and carry out.

**CAUTION** Refers to specific procedures to carry out for preventing damages to the vehicle.

**WARNING** Refers to specific procedures to carry out to prevent injuries to the repairer.



**Personal safety** Failure to completely observe these instructions will result in serious risk of personal injury.



**Safeguarding the environment** Sections marked with this symbol indicate the correct use of the vehicle to prevent damaging the environment.



**Vehicle intactness** The incomplete or non-observance of these regulations leads to the risk of serious damage to the vehicle and sometimes even the invalidity of the guarantee.

---



## INDEX OF TOPICS

**PRE-DELIVERY**

**PRECON**

**TECHNICAL DATA**

**DT**

**TOOLING**

**ATT**

**MAINTENANCE**

**MAN**

**TROUBLESHOOTING**

**RIC GUA**

**ELECTRICAL SYSTEM**

**IMP ELE**

**ENGINE FROM VEHICLE**

**MOT VE**

**ENGINE**

**MOT**

**INJECTION**

**INIEZ**

**SUSPENSIONS**

**SOSP**

**BRAKING SYSTEM**

**IMP FRE**

**CHASSIS**

**CARROZ**

# INDEX OF TOPICS

**P**RE-DELIVERY

**P**RECON

---

**Aesthetic inspection****Appearance check:**

- Paintwork
  - Fitting of plastics
  - Scratches
  - Dirt
- 

**Tightening torques inspection****Safety locks check**

Make sure that the marking is on the:

- Safety fasteners
- Fastening screws

**Safety fasteners:**

- Upper fastening of rear shock absorber
  - Rear shock absorber lower fastener
  - Brake calliper fixing
  - Front wheel axle nut
  - Wheel hub nut
  - Swingarm bolt - Frame
  - Swinging arm pin - Engine
  - Engine arm pin - Frame arm
  - Handlebar lock-nut
  - Lower steering ring nut
  - Upper steering ring nut
- 

**Electrical system**

Electrical system:

- Main switch
  - Headlamps: high beam lights, low beam lights, tail lights, parking lights and their warning lights
  - Headlight adjustment according to regulations in force
  - Rear light, parking light, stop light
  - Front and rear stop light switches
  - Turn indicators and their warning lights
  - Instrument panel lights
  - Instrument panel: fuel and temperature indicator
  - Instrument panel warning lights
-

- Horn
- Starter

**TO ENSURE MAXIMUM PERFORMANCE, THE BATTERY MUST BE CHARGED BEFORE USE. INADEQUATELY CHARGING THE BATTERY WITH A LOW ELECTROLYTE LEVEL BEFORE IT IS USED FOR THE FIRST TIME WITH SHORTEN THE LIFE OF THE BATTERY.**

**WARNING**

**KEEP THE BATTERY AWAY FROM NAKED FLAMES OR SPARKS WHILE IT IS CHARGED. REMOVE THE BATTERY FROM THE VEHICLE, DISCONNECTING THE NEGATIVE TERMINAL FIRST.**

**CAUTION**

**WHEN INSTALLING THE BATTERY, ATTACH THE POSITIVE LEAD FIRST AND THEN THE NEGATIVE ONE.**

**WARNING**

**BATTERY ELECTROLYTE IS TOXIC AND IT MAY CAUSE SERIOUS BURNS. IT CONTAINS SULPHURIC ACID. AVOID CONTACT WITH EYES, SKIN AND CLOTHING.**

**IF IT ACCIDENTALLY COMES INTO CONTACT WITH YOUR EYES OR SKIN, WASH WITH ABUNDANT WATER FOR APPROX. 15 MIN. AND SEEK IMMEDIATE MEDICAL ATTENTION.**

**IF ACCIDENTALLY SWALLOWED, IMMEDIATELY DRINK LARGE QUANTITIES OF WATER OR VEGETABLE OIL. SEEK IMMEDIATE MEDICAL ATTENTION.**

**BATTERIES PRODUCE EXPLOSIVE GAS; KEEP CLEAR OF NAKED FLAMES, SPARKS OR CIGARETTES. VENTILATE THE AREA WHEN RECHARGING INDOORS. ALWAYS WEAR EYE PROTECTION WHEN WORKING IN THE PROXIMITY OF BATTERIES.**

**KEEP OUT OF THE REACH OF CHILDREN.**

**CAUTION**

**NEVER USE FUSES WITH A CAPACITY HIGHER THAN THAT RECOMMENDED. USING A FUSE OF UNSUITABLE RATING MAY SERIOUSLY DAMAGE THE VEHICLE OR EVEN CAUSE A FIRE.**



**THE FOLLOWING INDICATIONS REFER TO THE VERSION MARKETED IN CHINA.**

The vehicle is equipped with OBD socket (On-Board Diagnostics), located in the battery compartment, used to monitor its correct operation.

**N.B.**

**FOR EVERY DISCONNECTION OF THE BATTERY POWER AND/OR ITS REPLACEMENT, THE RED POSITIVE CABLE OF THE OBD SOCKET SHOULD BE CORRECTLY CONNECTED TO THE POSITIVE POLE.**



---

## Levels check

Level check:

- Hydraulic braking system fluid level.
  - Rear hub oil level.
  - Engine coolant level.
- 

## Road test

**Test ride:**

- Cold start
  - Instrument operations
  - Response to throttle control
  - Stability on acceleration and braking
  - Front and rear brake efficiency
  - Front and rear suspension efficiency
  - Abnormal noise
- 

## Static test

Static control after the test drive:

- Warm start
- Starter operation
- Minimum holding (turning the handlebar)
- Uniform turning of the steering
- Possible leaks

**CAUTION**

**CHECK AND ADJUST TYRE PRESSURE WITH TYRES AT AMBIENT TEMPERATURE.**

**CAUTION**

**NEVER EXCEED THE RECOMMENDED INFLATION PRESSURES SINCE THE TYRES MAY BURST.**

---

## Functional inspection

Functional Checks:

Braking system (hydraulic)

- Lever travel

Braking system (mechanical)

- Lever travel

Clutch

- Proper functioning check
-

Engine

- Check throttle control travel

Others

- Check documentation
  - Check the chassis and engine numbers
  - Tool kit
  - Licence plate fitting
  - Locks checking
  - Tyre pressure check
  - Fitting of mirrors and possible accessories
- 

### **Specific operations for the vehicle**

**N.B.**

**AT EACH SCHEDULED SERVICE, USE THE DIAGNOSTIC TOOL TO CHECK FOR ERRORS AND CHECK THAT ALL PARAMETERS ARE CORRECT. ENSURE THAT THE VEHICLE CALIBRATION IS UP TO DATE AFTER UPDATING THE DIAGNOSTIC TOOL.**

**CAUTION**

**AFTER THE PROVIDED MAINTENANCE PROGRAM IS INDICATED TO PROCEED WITH THE MAINTENANCE OF THE VEHICLE STARTING FROM THE SERVICE OF 5,000 Km (3,106 mi) OR 5 MONTHS.**

---

# INDEX OF TOPICS

**TECHNICAL DATA**

**DT**

---

## Rules

This section describes general safety rules for any maintenance operations performed on the vehicle.

---

### Safety rules

- If work can only be done on the vehicle with the engine running, make sure that the premises are well ventilated, using special extractors if necessary; never let the engine run in an enclosed area. Exhaust fumes are toxic.
  - The battery electrolyte contains sulphuric acid. Protect your eyes, clothes and skin. Sulphuric acid is highly corrosive; in the event of contact with your eyes or skin, rinse thoroughly with abundant water and seek immediate medical attention.
  - The battery produces hydrogen, a gas that can be highly explosive. Do not smoke and avoid sparks or flames near the battery, especially when charging it.
  - Fuel is highly flammable and it can be explosive given some conditions. Do not smoke in the working area, and avoid naked flames or sparks.
  - Clean the brake pads in a well-ventilated area, directing the jet of compressed air carefully to avoid the risk of inhaling dust produced by worn friction material. Even though the latter contains no asbestos, inhaling dust is harmful.
- 

### Maintenance rules

- Use original PIAGGIO spare parts and lubricants recommended by the Manufacturer. Non-original or non-conforming spare parts may damage the vehicle.
  - Use only the appropriate tools designed for this vehicle.
  - Always use new gaskets, seal rings and cotter pins when reassembling.
  - After removal, clean the components using non-flammable or low flash-point solvents. Lubricate all the work surfaces, except tapered couplings, before refitting these parts.
  - After refitting, make sure that all the components have been installed correctly and work properly.
  - Use only equipment with metric sizes for removal, service and reassembly operations. Metric bolts, nuts and screws are not interchangeable with coupling members using English measurements. Using unsuitable coupling members and tools may damage the vehicle.
  - When carrying out maintenance operations on the vehicle that involve the electrical system, make sure the electrical connections have been made properly, particularly the ground and battery connections.
-

## Vehicle identification

### FRAME IDENTIFICATION NUMBER:

The frame identification number is inside the front case under a snap-on cover.



### ENGINE IDENTIFICATION NUMBER:

The engine identification number is stamped in the rear part of the engine near the shock absorber lower support.



## Vehicle Data

For 125 E3 Vietnam MY2019 version

### VEHICLE DATA

Specification	Desc./Quantity
Frame	Tubular steel frame
Front suspension	Hydraulic telescopic fork with Ø 30-mm stem.
Rear suspension	Double-acting shock absorber, adjustable to five positions at preloading.
Front brake	Ø 240 mm disc brake with dual piston floating calliper.
Rear brake	Ø 140 mm mechanically operated drum brake controlled from LH handlebar lever.
Wheel rims type	Light alloy.
Front rim	16" x 2.15
Rear rim	14 x 2.50"
Front tire	Tubeless, 90/80 - 16" 51J
Rear tire	Tubeless, 100/80 - 14" 54J
Front tire pressure (with passenger)	1.6 bar (1.6 bar)
Rear tire pressure (with passenger)	2.0 bar (2.2 bar)
Kerb weight	125 kg
Maximum weight limit	275 kg
Battery	12V -6Ah

For 125 E4 China MY2019 version

### VEHICLE DATA

Specification	Desc./Quantity
Frame	Tubular steel frame
Front suspension	Hydraulic telescopic fork with Ø 30-mm stem.

<b>Specification</b>	<b>Desc./Quantity</b>
Rear suspension	Double-acting shock absorber, adjustable to five positions at preloading.
Front brake	Ø 240 mm disc brake with dual piston floating calliper.
Rear brake	Ø 139 mm mechanically operated drum brake controlled from LH handlebar lever.
Wheel rims type	Light alloy.
Front rim	16" x 2.15
Rear rim	14 x 2.50"
Front tire	Tubeless, 90/80 - 16" 51J
Rear tire	Tubeless, 100/80 - 14" 54J
Front tire pressure (with passenger)	1.6 bar (1.6 bar)
Rear tire pressure (with passenger)	2.0 bar (2.2 bar)
Kerb weight	124 kg
Maximum weight limit	290 kg
Battery	12V -6Ah

## Engine Data

### FOR EUROPE VERSION

#### **SPECIFICATIONS - 125 ENGINES**

<b>Specification</b>	<b>Desc./Quantity</b>
Engine	Single-cylinder, 4-stroke Piaggio i-Get
Engine capacity	124 cm <sup>3</sup>
Bore per stroke	52 x 58.6 mm
Max. power	8.0 kW at 7,500 rpm
MAX torque	11 Nm at 6,000 rpm
Compression ratio	10 : 1
Timing system	3 valves, single overhead camshaft, chain-driven.
Valve clearance (cold engine)	Intake: 0.08 mm Exhaust: 0.08 mm
Spark plug	NGK CR7EB
Power supply	Electronic injection with Ø26 mm throttle body, single injector.
Cooling	Forced-air circulation cooling.
Lubrication	Wet sump
Starting	Electric
Gearbox	Continuously variable transmission with torque server
Clutch	Automatic centrifugal dry clutch
Fuel	Unleaded gasoline E10 (95 R.O.N.)
Exhaust silencer	Absorption-type exhaust silencer with catalytic converter.
Emissions compliance	EURO 4

#### **SPECIFICATIONS - 150 ENGINES**

<b>Specification</b>	<b>Desc./Quantity</b>
Engine	Single-cylinder, 4-stroke Piaggio i-Get
Engine capacity	155 cm <sup>3</sup>
Bore per stroke	58 x 58.6 mm
Max. power	9.6 kW at 7,750 rpm
MAX torque	13 Nm at 5,250 rpm
Compression ratio	10.5: 1
Timing system	3 valves, single overhead camshaft, chain-driven.
Valve clearance (cold engine)	Intake: 0.08 mm Exhaust: 0.08 mm
Spark plug	NGK CR7EB
Power supply	Electronic injection with Ø28 mm throttle body, single injector.
Cooling	Forced-air circulation cooling.
Lubrication	Wet sump
Starting	Electric
Gearbox	Continuously variable transmission with torque server
Clutch	Automatic centrifugal dry clutch
Fuel	Unleaded gasoline E10 (95 R.O.N.)
Exhaust silencer	Absorption-type exhaust silencer with catalytic converter.
Emissions compliance	EURO 4

### FOR ASIA-PACIFIC VERSION

**ENGINE SPECIFICATIONS**

Specification	Desc./Quantity
Engine	Single-cylinder, 4-stroke Piaggio i-Get
Engine capacity	124.5 cm <sup>3</sup>
Bore per stroke	52 x 58.6 mm
Max. power	7.6 kW at 7,600 rpm
MAX torque	10.2 Nm at 6,000 rpm
Compression ratio	10 : 1
Timing system	3 valves, single overhead camshaft, chain-driven.
Valve clearance (cold engine)	Intake: 0.08 mm Exhaust: 0.08 mm
Spark plug	NGK CR7EB
Power supply	Electronic injection with Ø26 mm throttle body, single injector.
Cooling	Forced-air circulation cooling.
Lubrication	Wet sump
Starting	Electric
Gearbox	Continuously variable transmission with torque server
Clutch	Automatic centrifugal dry clutch
Fuel	Unleaded gasoline E10 (95 R.O.N.)
Exhaust silencer	Absorption-type exhaust silencer with catalytic converter.
Emissions compliance	EURO 3

**For 125 E4 China MY2019 version****ENGINE SPECIFICATIONS**

Specification	Desc./Quantity
Engine	Single-cylinder, 4-stroke Piaggio i-Get
Engine capacity	124 cm <sup>3</sup>
Bore per stroke	52 x 58.6 mm
Max. power	7.6 kW at 7,600 rpm
MAX torque	10.2 Nm at 6,000 rpm
Compression ratio	10 : 1
Timing system	3 valves, single overhead camshaft, chain-driven.
Valve clearance (cold engine)	Intake: 0.08 mm Exhaust: 0.08 mm
Spark plug	NGK CR7EB
Power supply	Electronic injection with Ø26 mm throttle body, single injector.
Cooling	Forced-air circulation cooling.
Lubrication	Wet sump
Starting	Electric
Gearbox	Continuously variable transmission with torque server
Clutch	Automatic centrifugal dry clutch
Fuel	Unleaded gasoline E10 (95 R.O.N.)
Exhaust silencer	Absorption-type exhaust silencer with catalytic converter.
Emissions compliance	EURO 4

**Dimensions and mass****FOR EUROPE VERSION**

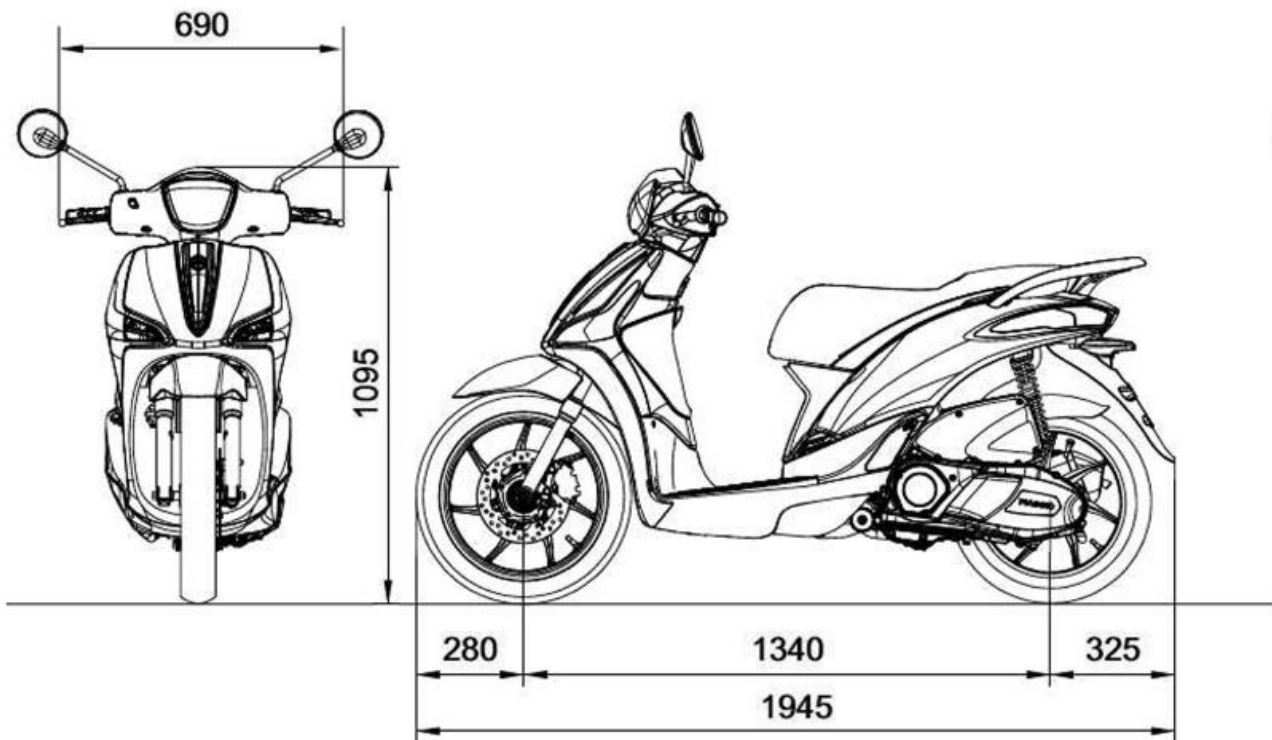

**WEIGHT AND DIMENSIONS**

Specification	Desc./Quantity
length	1,945 mm
width	690 mm
Wheelbase	1,340 mm
height	1,095 mm
Kerb weight	124 kg
Maximum weight limit	290 kg

**FOR ASIA-PACIFIC VERSION**

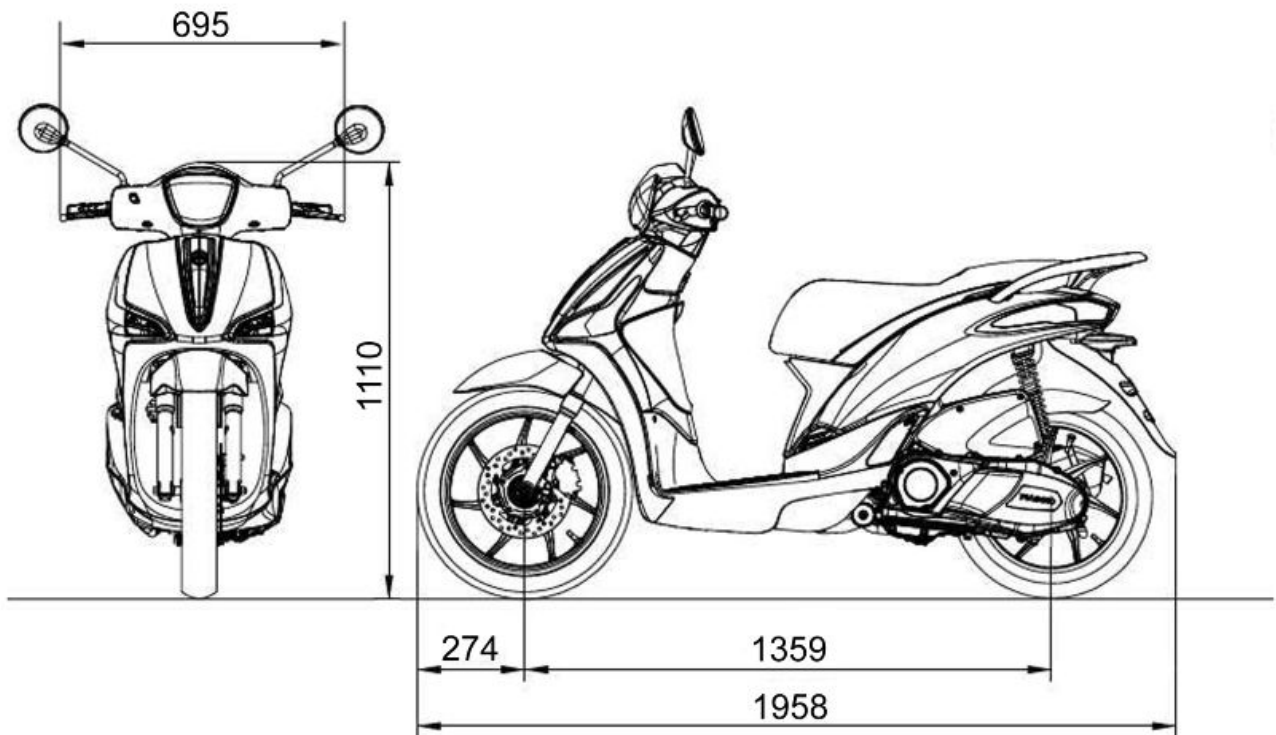

**WEIGHT AND DIMENSIONS**

Specification	Desc./Quantity
length	1,958 mm
width	695 mm
Wheelbase	1,359 mm
height	1,110 mm
Kerb weight	114 kg
Maximum weight limit	270 kg

**Transmission**

**TRANSMISSION**

Specification	Desc./Quantity
Primary drive	Automatic expandable pulley variator with torque server, V-belt, automatic self-ventilated centrifugal dry clutch.
Final drive reduction gear	Gear reduction unit in oil bath.

**Capacities**

**CAPACITY**

Specification	Desc./Quantity
Engine oil quantity	1,340 cm <sup>3</sup> (of which 120 cm <sup>3</sup> in the filtering cartridge)
Hub oil quantity	325 cm <sup>3</sup>
Fuel tank capacity	6 ± 0.5 litres (1 l of which is reserve)

**MEASUREMENT UNITS CONVERSION - FROM THE ANGLO-SAXON SYSTEM TO THE INTERNATIONAL SYSTEM (I.S.).**

Specification	Desc./Quantity
1 Inch (in)	25.4 Millimetres (mm)
1 Foot (ft)	0.305 Metres (m)

Specification	Desc./Quantity
1 Mile (mi)	1.609 Kilometres (km)
1 US gallon (gal US)	3.785 Litres (l)
1 Pound (lb)	0.454 Kilograms (Kg)
1 Cubic inch (in <sup>3</sup> )	16.4 Cubic centimetres (cm <sup>3</sup> )
1 Pound per foot (lb ft)	1.356 Newton metres (N m)
1 Mile per hour (mi/h)	1.602 Kilometres per hour (km/h)
1 Pound per square foot (PSI)	0.069 (bar)
1 Fahrenheit (°F)	32+(9/5) Celsius (°C)

## Electrical system

### ELECTRICAL COMPONENTS

Specification	Desc./Quantity
Spark plug	NGK CR7EB
Battery	12 V - 6 Ah Sealed
Alternator	alternating current

## Frame and suspensions

### FRAME AND SUSPENSION

Specification	Desc./Quantity
Frame	Tubular steel frame
Front suspension	Hydraulic telescopic fork with Ø 30-mm stem.
Rear suspension	Double-acting shock absorber, adjustable to five positions at preloading.

## Brakes

### BRAKES

Specification	Desc./Quantity
Front brake	Ø 240mm disc brake with dual piston floating calliper; Braking assisted by single-channel ABS system.
Rear brake	Ø 140 mm mechanically operated drum brake controlled from LH handlebar lever.

## Wheels and tyres

### WHEELS AND TYRES

Specification	Desc./Quantity
Front rim	16" x 2.15
Front tire	Tubeless, 90/80 - 16" 51J
Rear rim	14 x 2.50"
Rear tire	Tubeless, 100/80 - 14" 54J

## Tightening Torques

### LUBRICATION

Name	Torque in Nm
Crankcase timing cover screws	11 to 13
Screws fixing oil pump to the crankcase	4 - 6
Pump rod screw	11 - 13

Name	Torque in Nm
Minimum oil pressure sensor locking	12 - 14 (LOCTITE 5091 Edge closure between metal body and plastic block)

### **TRANSMISSION AND FINAL REDUCTION**

Name	Torque in Nm
Transmission cover screws	11 to 13
Final reduction cover screws	24 to 27
Driven pulley fixing nut	53 - 59
Oil drain screw	14.7 - 16.7
Freewheel fixing screws	10 - 11
driving pulley retainer nut	75 - 83

### **HEAD AND CYLINDER**

Name	Torque in Nm
Head cover screws	10.8 - 12.7
Cylinder head nut (PRE-TIGHTENING)	6 - 8
Cylinder head nut (TIGHTENING)	9 - 11 (Tighten to the prescribed torque and then proceed with 270.0°±5.0° rotation)
Cylinder stud bolt fitting	See section ENGINE/LUBRICATION/STUD BOLT
Throttle body clamp screws	1.3 to 1.7
Tensioner spring retaining screw	5 to 6
Fastener chain tensioner	11 to 13
Thermostat cover screws	3 - 4
Pressure reducer counterweight retainer screw	7 to 8.5
Injection manifold fixing screws	11 to 13
Valve clearance adjustment screw	6 - 9
Spark plug tightening	10 to 12
Timing system sprocket fixing screw	4 - 6
Screws fixing cylinder to crankcase	10.8 - 12.7
Head blow by	3 - 4

### **CRANKCASE**

Name	Torque in Nm
Calibrated fixing dowel	5 to 7
Oil filter cover	24 to 30
Engine oil level shaft	1.3 to 1.7
Engine-crankcase coupling screws	11 to 13
Rear brake screw	15 to 17
Oil sensor	12 - 14
Oil filter	5 to 6
Oil drain screw	14.7 - 16.7
Oil pump bulkhead screw	4 - 6
Freewheel fixing screws	10 - 11
Oil pump fixing screw	5 to 6
Oil pump command sprocket screw	10 - 14
Rotor cover	1 - 1.50
Rotor clamp	3 - 4

### **FLYWHEEL COVER**

Name	Torque in Nm
Pick-up screws	3 - 4
Stator fixing screws	5 - 6 (Loctite 242)
Stator cable plates clamping screws	3 - 4
Fixing clamps of head pump cover by-pass pipe	1.3 to 1.7
Coil fixing screw	11 to 13

### **FLYWHEEL**

Name	Torque in Nm
Flywheel cover screw	11 to 13
Starter sprocket check fixing screw	5 to 6
Starter motor fastening screws	11 to 13
Flywheel fixing nut	100 - 110
Freewheel fixing screws	10 - 11

**SILENCER**

Name	Torque in Nm
Silencer heat guard fixing screw	4 - 5
Screws fixing silencer to the crankcase	24 to 27
Lambda probe tightening on exhaust manifold	40 - 50

**STEERING ASSEMBLY**

Name	Torque in Nm
Upper steering ring nut	35 - 40
Lower steering ring nut	12 - 14
handlebar fixing screw	45 - 55
Mirror set screw	24 - 26

**FRAME ASSEMBLY**

Name	Torque in Nm
Screw fixing plate with silent block - frame	36 - 44
Frame-swinging arm bolt	40 - 45
Swinging arm pin - engine	40 - 45
Shock absorber - frame nut	20 - 25
Centre stand pin	40 - 45
Side stand bolt*	12 - 16

\* lock using loctite 246

**FRONT SUSPENSION**

Name	Torque in Nm
Front brake calliper fixing screws	19.6 - 24.5
Front wheel axle	44.1 - 49
Fork bottom screw	25 - 34
Fork top screw	25 - 34
Upper steering ring nut	35 - 40
Lower steering ring nut	12 - 14
ABS sensor	6 - 8

**REAR SUSPENSION**

Name	Torque in Nm
shock absorber - frame	20 - 25
Rear shock absorber - bracket	40 - 45
Screws fastening the rear shock absorber bracket - engine	20 - 25
Rear wheel axle nut	104 - 126

**BRAKING SYSTEM**

Name	Torque in Nm
brake calliper pipe	20 - 25
Brake fluid pump-hose joint	20 - 25
Rear brake adjustment nut	5
Brake pad fastening screw	15 - 20
Pump U bolt screw	8
Brake pump reservoir screws	15 - 20
Disc tightening screw (Apply LOCTITE 243 medium-strength threadlock)	8 - 10 Nm
Oil bleeding valve	8 - 12
Pipe - ABS Modulator	20 - 25

**Overhaul data**

**Assembly clearances**

**Cylinder - piston assy.**

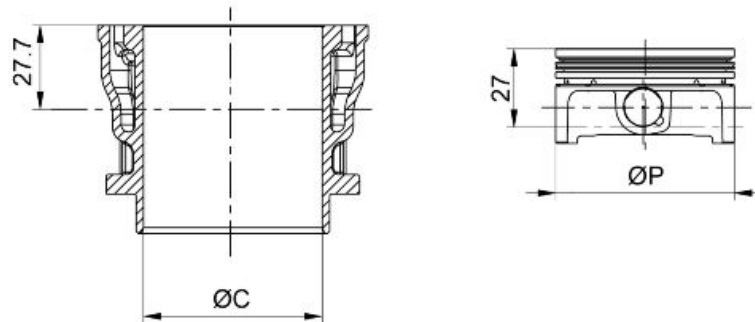

**CYLINDER - PISTON (125)**

Specification	Desc./Quantity
Plunger diameter	51.961 (±0.014) mm
Cylinder diameter	52 (+0.008 -0.020) mm

**CYLINDER - PISTON (150)**

Specification	Desc./Quantity
Plunger diameter	57.947 (± 0.014) mm
Cylinder diameter	58 (+0.008 -0.020) mm

**COUPLING CATEGORIES (125)**

Name	Initials	Cylinder	Piston	Play on fitting
cylinder - piston	A	51.980 - 51.987	51.947 - 51.954	0.026 - 0.040
cylinder - piston	B	51.987 - 51.994	51.954 - 51.961	0.026 - 0.040
cylinder - piston	C	51.994 - 52.001	51.961 - 51.968	0.026 - 0.040
cylinder - piston	W	52.001 - 52.008	51.968 - 51.975	0.026 - 0.040

**COUPLING CATEGORIES (150)**

Name	Initials	Cylinder	Piston	Play on fitting
cylinder - piston	A	57.980 - 57.987	57.933 - 57.940	0.040 - 0.054
cylinder - piston	B	57.987 - 57.994	57.940 - 57.947	0.040 - 0.054
cylinder - piston	C	57.994 - 58.001	57.947 - 57.954	0.040 - 0.054
cylinder - piston	W	58.001 - 58.008	58.954 - 58.961	0.040 - 0.054

**N.B.**

**THE PISTON MUST BE INSTALLED WITH THE ARROW FACING TOWARDS THE EXHAUST SIDE, THE PISTON RINGS MUST BE INSTALLED WITH THE WORD «TOP» OR THE STAMPED MARK FACING UPWARDS.**

- Check the pin external diameter.

**Characteristic**

**Pin external diameter**

14 (+0 -0.004) mm

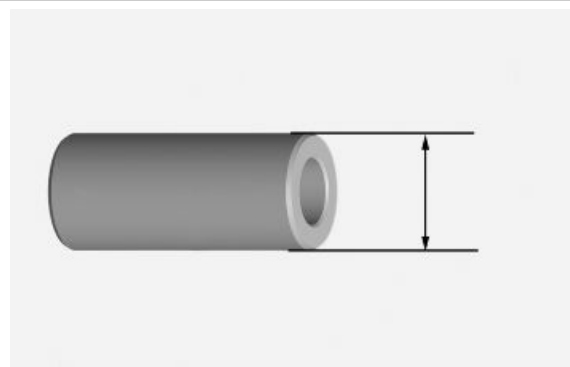

- Measure the diameter of the housings on the piston

**Characteristic**

**Standard diameter**

14 (+0.006 +0.001) mm

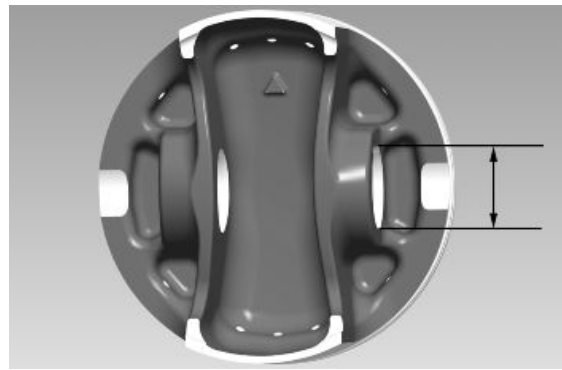

- Carefully clean the seal housings.
- Measure the coupling clearance between the sealing rings and the piston grooves using suitable sensors, as shown in the diagram.
- If the clearance is greater than that indicated in the table, replace the piston.
- Check the clearance upon mounting (A) of the bands:

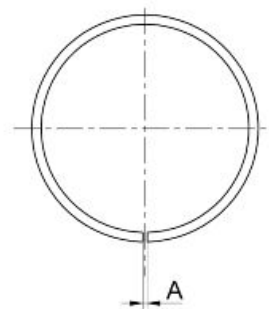

**N.B.**

**MEASURE THE CLEARANCE BY INSERTING THE BLADE OF THE FEELER THICKNESS GAUGE FROM THE SECOND SEAL SIDE.**

**ASSEMBLY CLEARANCE OF BANDS - SEAL RINGS (125)**

DENOMINATION	DIMENSIONS	ASSEMBLY CLEARANCES (A)
1° compression ring (mm)	52x0.8	0.20 - 0.35
2° compression ring (mm)	52x1.0	0.20 to 0.45
Oil scraper rings (mm)	52x2.0	0.25 to 0.55

**ASSEMBLY CLEARANCE OF BANDS - SEAL RINGS (150)**

DENOMINATION	DIMENSIONS	ASSEMBLY CLEARANCES (A)
1° compression ring (mm)	58x0.8	0.20 - 0.35
2° compression ring (mm)	58x1.0	0.20 to 0.45
Oil scraper rings (mm)	58x2.0	0.25 to 0.55

- Check that the head coupling surface is not worn or misshapen.
- Pistons and cylinders are classified according to diameter. The coupling is carried out in pairs (A-A, B-B, C-C, D-D).

**Crankcase - crankshaft - connecting rod**

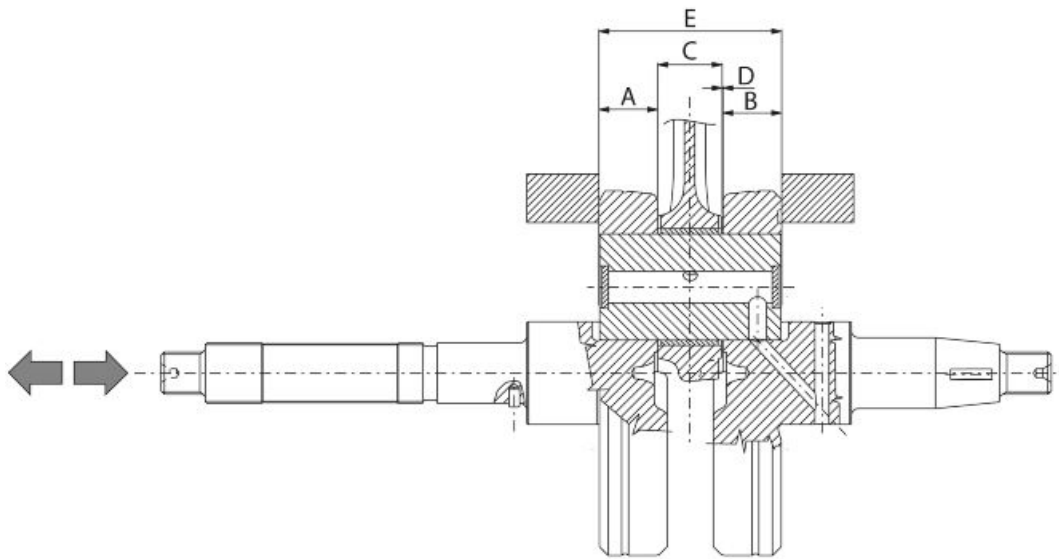

**AXIAL CLEARANCE BETWEEN CRANKSHAFT AND CONNECTING ROD**

Name	Code	Dimensions	Assembly clearance
Transmissionside half-shaft	A	18.1 (+0; -0.05) mm	D = 0.20 - 0.50
Flywheel-side halfshaft	B	18.1 (+0; -0.05) mm	D = 0.20 - 0.50
Connecting rod	C	15 (-0.10; -0.15) mm	D = 0.20 - 0.50
Spacer tool	E	51.4 (+0.05; +0) mm	D = 0.20 - 0.50

**Diameter of crankshaft bearings.**

Measure the bearings on both axes x-y.

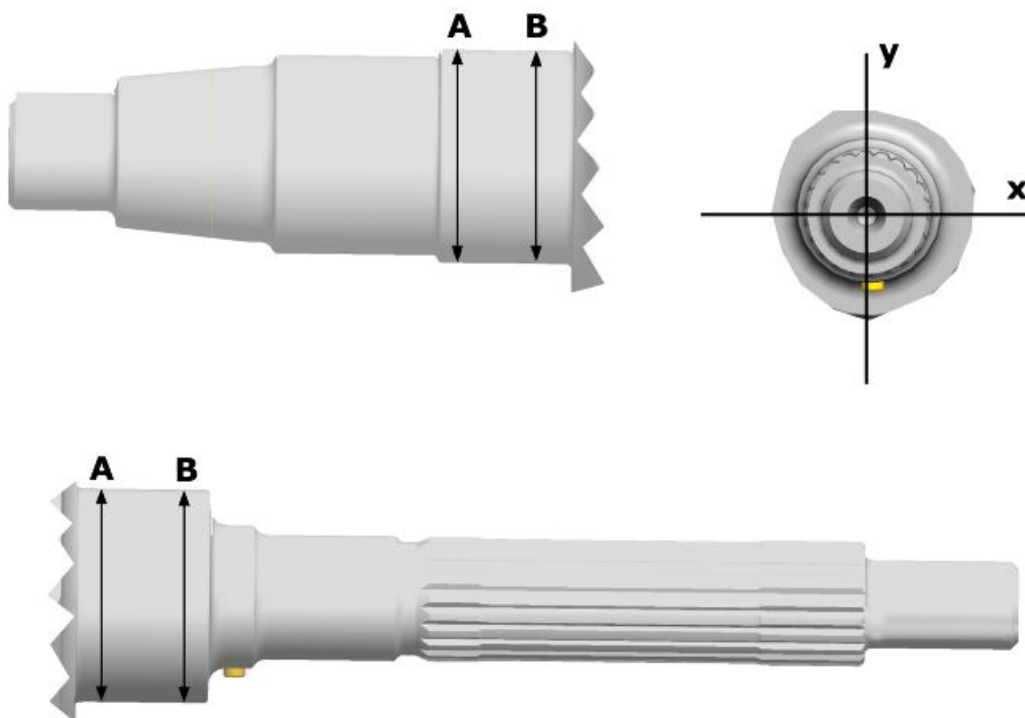

**CRANKSHAFT**

Specification	Desc./Quantity
Crankshaft bearings: Standard diameter: Cat. 1	26.998 - 27.004 mm
Crankshaft bearings: Standard diameter: Cat. 2	27.004 - 27.010 mm

- To obtain a good bushing lubrication it is necessary to have both an optimal lubricating pressure and a good oil flow rate; the bushings must be correctly positioned so as not to obstruct the oil supply channels.

**Characteristic**

«A»

AXIS CYLINDER

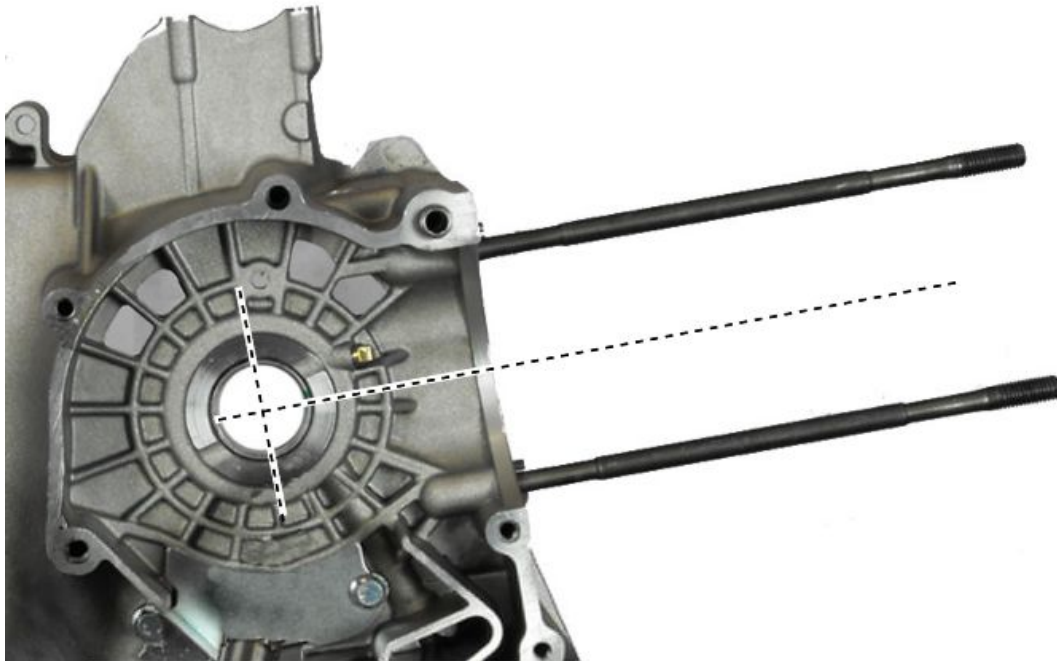

- The main bushings have 2 half-bearings, 1 with and 1 without the lubrication channel.
- The solid half-bearing is intended to stand the thrusts caused by combustion, and for this reason it is arranged opposite the cylinder.
- To prevent shutters in the oil feeding channels, the matching surface of the two half-bearings must be perfectly orthogonal to the cylinder axis, as shown in the photo.

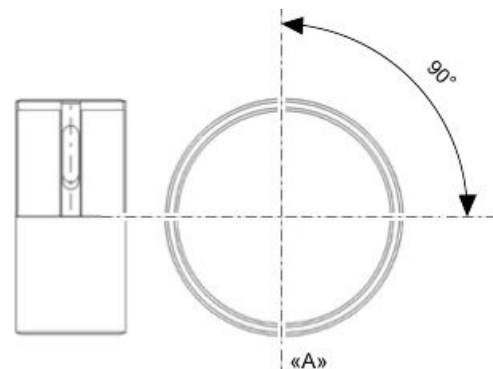

**Characteristic**

«A»

AXIS CYLINDER

**BEARINGS**

TYPE	IDENTIFICATION	CRANKSHAFT HALF-BEARING
B	BLUE	1.971 - 1.976
C	YELLOW	1.974 - 1.979
E	GREEN	1.977 - 1.982

- The section of the oil feeding channels is also influenced by the driving depth of the bushings.
- Visually check the wear of the bushings: in the coupling ends shown in the photo the bushing usually keeps the original look, check in the rest of the bushing if there is evident removal of material. If this occurs as stated, proceed to replace the crankcase halves.



**N.B.**

**SMALL MARKS AND SCRATCHES OF THE SHAFT ROTATION ARE NORMAL SIGNS OF ENGINE USAGE, AND DO NOT AFFECT THE CORRECT FUNCTIONING.**

**Measurement of crankcase halves - crankshaft coupling clearance**

- The nominal diameters of the bushings, even if of the same coupling category, may differ by hundredths due to the plastic slackening of the material of the crankcase due to the driving load.
- Measure along the axis of the «A» cylinder, using a bore meter at two depths indicated in the figure, the diameter of the bushings.
- After measuring the two diameters, take the average.

**Characteristic**

«A»

AXIS CYLINDER

- The bushings housing hole in the crankcase half is divided into two categories depending on the size, Category 1 and Category 2.

**DIAMETER OF CRANKCASE WITHOUT BUSHING**

Specification	Desc./Quantity
CAT 1	30.959 - 30.965 mm
CAT 2	30.953 - 30.959 mm

- Combine the shaft with two category 1 crankwebs with the category 1 crankcase (or cat. 2 with cat. 2). Furthermore a spare crankcase cannot be matched with a crankshaft with mixed categories. The spare crankshaft has half-shafts of the same category.
- According to the classification of the shaft CAT.1 - CAT.2 combine a complete crankcase pre-fitted with suitable bushings according to the starting shaft.

**CATEGORIES**

CRANKCASE HALVES	ENGINE HALF-SHAFT	BUSHING
Cat. 1	Cat. 1	E
Cat. 2	Cat. 2	B
Cat. 1	Cat. 2	C
Cat. 2	Cat. 1	C

**THE CRANKSHAFT** is available in two **CATEGORIES**:

**Characteristic**

**Crankshaft category:**

**CAT. 1 - CAT. 2**

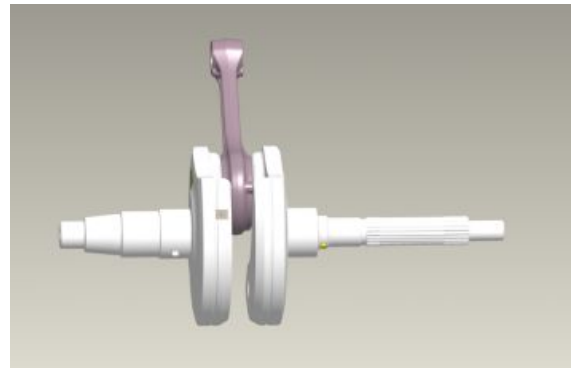

#### **CRANKSHAFT CATEGORY IDENTIFICATION:**

The identification is indicated on the counterweight shoulder «\*1 - \*2», if carried out with micropinholing. Otherwise, «1 - 2» if done manually with an electric pen. The spare part identification is located on the package with a **drawing number** plus **FC1/FC2** or **(001/002)**.

If a crankshaft comprising two half-shafts of different categories needs to be replaced, also replace both crankcase halves, combining the two components (Shaft and Crankcase) featuring the same category.

## **Cylinder Head**

Before performing head service operations, thoroughly clean all coupling surfaces. Note the position of the springs and the valves so as not to change the original position during refitting

- Using a trued bar and a feeler gauge, check that the cylinder head surface is not worn or distorted.

#### **Characteristic**

**Maximum allowable run-out:**

0.03 mm

- In case of faults, replace the head.
- Check the sealing surfaces for the exhaust manifold.
- Check that the camshaft and the rocker pin capacities exhibit no wear.
- Check that the head cover shows no signs of wear.
- Check that there is no cooling liquid leakage from the seals.

- Insert the valves into the cylinder head.
- Alternatively check the intake and exhaust valves.
- The test is carried out by filling the manifold with petrol and checking that the head does not ooze through the valves when these are just pressed with the fingers.





**HEAD BEARINGS**

Specification	Desc./Quantity
bearing «A»	Ø 10.000 (+0.015) mm
bearing «B»	Ø 28.000 (+0.007 +0.028) mm
bearing «C»	Ø 42.000 (+0.009 +0.034) mm

Measure the unloaded spring length

**Characteristic  
Standard length**

35.8 mm

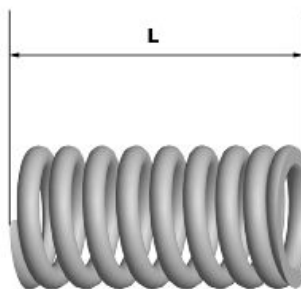

- Clean the valve seats of any carbon residues.
- Using the Prussian blue, check the width of the impression on the valve seat "V".

**Characteristic  
Standard value:**

1 - 1.3 mm

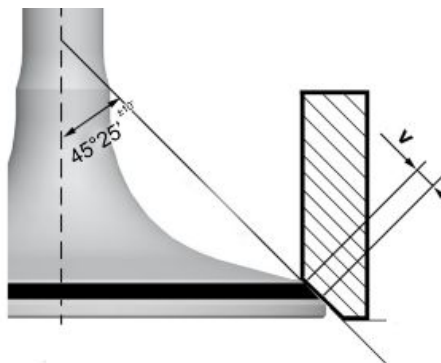

- If the impression width on the valve seat is larger than the prescribed limits, true the seats with a 45° mill and then grind.
- In case of excessive wear or damage, replace the head.

- Measure the diameter of the valve stems in the three positions indicated in the diagram.

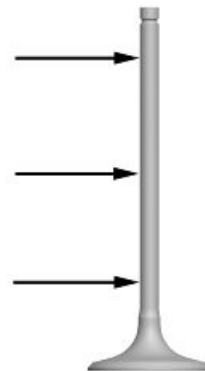

**STANDARD DIAMETER**

Specification	Desc./Quantity
Intake:	4.030 to 4.015 mm
Exhaust:	4.975 - 4.960 mm

- Calculate the clearance between the valve and the valve guide.

- Check the deviation of the valve stem by resting it on a «V» shaped abutment and measuring the extent of the deformation with a dial gauge.

**Characteristic**

**Limit value admitted:**

0.02 mm

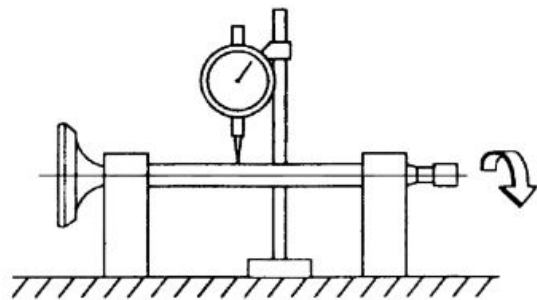

- Check the oscillation of the valve head by arranging a dial gauge at right angle relative to the valve head and rotate it on a "V" shaped abutment.

**Characteristic**

**Limit allowed:**

0.3 mm

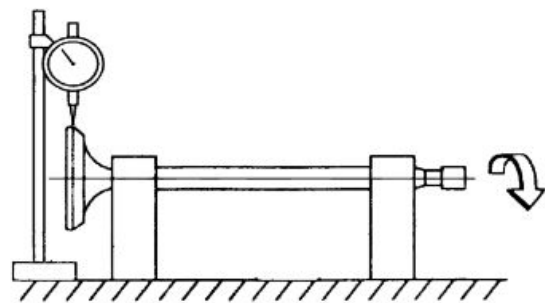

Measure the valve guide.

**Characteristic**

**Valve guide:**

4.3 ± 0.1 mm

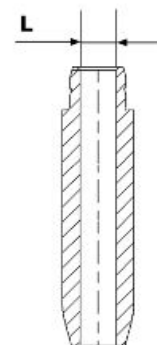

- After measuring the valve guide diameter and the valve stem diameter, check clearance between guide and stem.



**INTAKE**

Specification	Desc./Quantity
Standard clearance:	0.10 mm
Limit allowed:	0.08 mm

**EXHAUST**

Specification	Desc./Quantity
Standard clearance:	0.15 mm
Limit allowed:	0.1 mm

- Check that there are no signs of wear on the mating surface with the set screw articulated terminal.

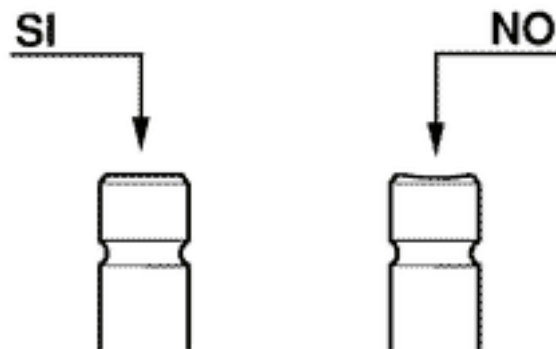

- If no anomalies are found during the above checks, you can use the same valves. To obtain better sealing performance, grind the valve seats. Grind the valves gently with a fine-grained lapping compound. During the grinding, keep the cylinder head with the valve axes in a horizontal position. This will prevent the lapping compound residues from penetrating between the valve stem and the guide (see figure).

**CAUTION**

**TO AVOID SCORING THE MATING SURFACE, DO NOT ROTATE THE VALVE WHEN NO LAPPING COMPOUND IS LEFT. CAREFULLY WASH THE CYLINDER HEAD AND THE VALVES WITH A SUITABLE PRODUCT FOR THE TYPE OF LAPPING COMPOUND BEING USED.**

**CAUTION**

**DO NOT REVERSE THE FITTING POSITIONS OF THE VALVES (RIGHT - LEFT).**

- Check that the camshaft bearings exhibit no scores or abnormal wear.
- Using a micrometer, measure the camshaft bearings.

**STANDARD DIAMETER**

Specification	Desc./Quantity
Camshaft check: Standard diameter	Bearing A Ø: 25.002 to 25.015 mm
Camshaft check: Standard diameter	Bearing B diameter: 12.002 to 12.013 mm

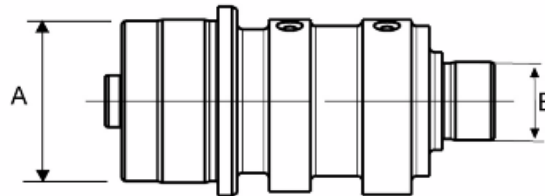

- Measure the external diameter of the rocking lever pins
- Check the rocker pins do not show signs of wear or scoring.
- Measure the internal diameter of each rocker

Check there are no signs of wear on the pad from contact with the cam and on the jointed adjustment plate.

**DIAMETER OF PINS AND ROCKING LEVERS**

Specification	Desc./Quantity
Rocking lever inside diameter: Standard diameter (C)	Ø 10.015 to 10.035 mm
Rocking lever pin diameter: Standard diameter (D)	Ø 10.015 to 10.023 mm

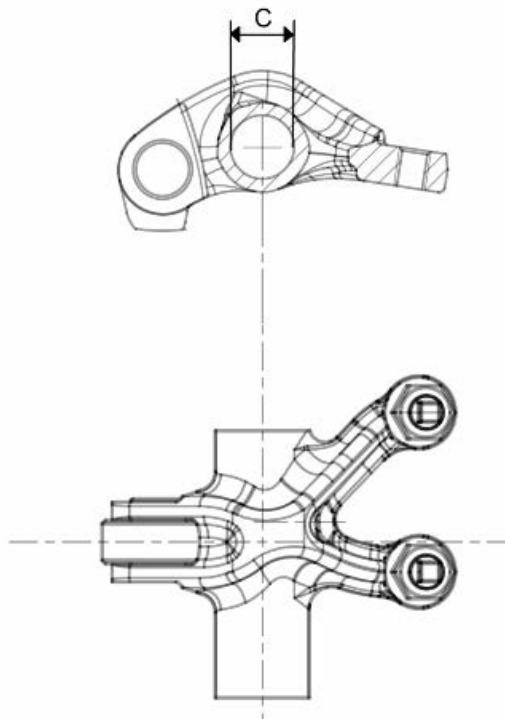

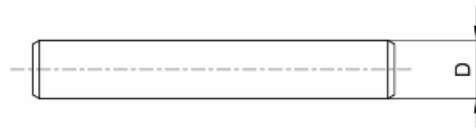

### Slot packing system

**Characteristic**

**Compression ratio**

(10.5±0.5):1

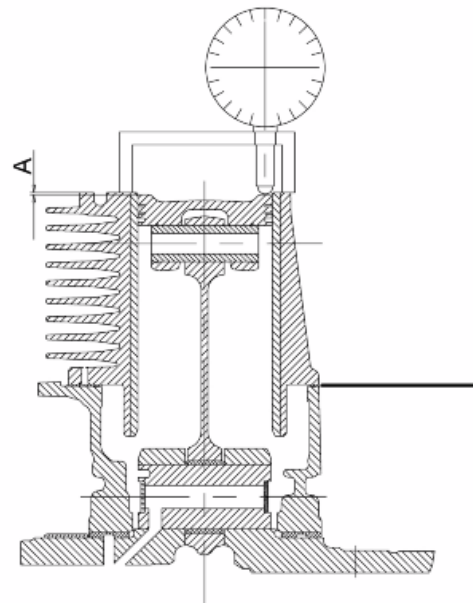

Measurement "A" to be taken is a value of piston re-entry, it indicates by how much the plane formed by the piston crown falls below the plane formed by the top of the cylinder. The further the piston falls inside the cylinder, the less the base gasket to be applied (to recover the compression ratio) and vice versa.

**N.B.**

**MEASUREMENT "A" MUST BE TAKEN WITHOUT ANY GASKET FITTED BETWEEN THE CRANK-CASE AND CYLINDER AND AFTER RESETTING THE DIAL GAUGE, EQUIPPED WITH A SUPPORT, ON A GROUND PLANE**

**ENGINE 125/150 SHIMMING**







Name	Measure A	Thickness
Shimming	0 - -0.1	0.8 ± 0.05
Shimming	-0.1 - -0.3	0.6 ± 0.05
Shimming	-0.3 - -0.4	0.4 ± 0.05

# INDEX OF TOPICS

TOOLING

ATT

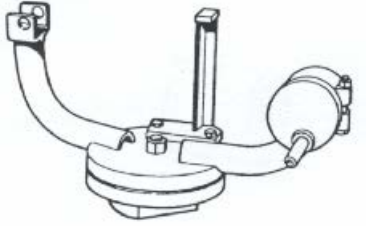
**SPECIFIC TOOLS**

Stores code	Description	
001330Y	Tool for fitting steering seats	
001467Y008	Clamp to extract 17 mm ø bearings	
001467Y009	Bell for OD 42-mm bearings	
001467Y013	Calliper to extract ø 15-mm bearings	
002465Y	Calliper for circlips	
005095Y	Engine support	
006029Y	Punch for fitting steering bearing on the steering tube	

Stores code	Description	
02004Y	Punch for removing steering bearings from headstock	
02005Y	Wrench for steering tube ring nut	
020074Y	Support base for checking crankshaft alignment	
020150Y	Air heater mounting	
020151Y	Air heater	
020193Y	Oil pressure gauge	

**Stores code**

**Description**

020263Y

Driven pulley assembly sheath



020271Y

Tool for removing-fitting silent bloc



020329Y

Mity-Vac vacuum pump

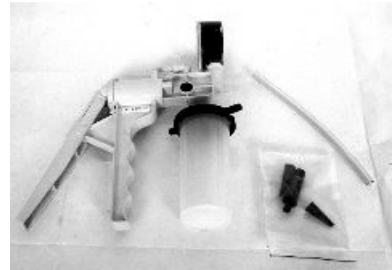

020330Y

Stroboscopic light to check timing









020331Y

Digital multimeter



Stores code	Description	
020332Y	Digital rpm indicator	
020334Y	Multiple battery charger	
020335Y	Magnetic mounting for dial gauge	
020357Y	32 x 35-mm Adaptor	
020358Y	37 x 40 mm Adaptor	

Stores code	Description	
020359S	42 x 47 mm Adaptor	
020360S	52 x 55 mm adaptor	
020363Y	20-mm guide	
020364Y	25-mm guide	
020375Y	28 x 30 mm adaptor	
020376Y	Adaptor handle	
020382Y	Tool to extract valve cotters	

Stores code	Description	
020412Y	15-mm guide	
020424Y	Driven pulley roller casing fitting punch	
020426Y	Piston fitting fork	
020427Y	Piston fitting ring	
020431Y	Valve oil seal extractor	
020434Y	Union for oil pressure measurement	

Stores code	Description	
020444Y011	adapter ring	

020444Y009 wrench 46 x 55



020439Y	17-mm guide	
---------	-------------	--

020442Y Pulley lock wrench



020444Y	Tool for installing/removing clutch on/ from driven pulley	
---------	---	---

020480Y Fuel pressure measurement kit



Stores code	Description	
020487Y	Fork oil seal extractor	 <p>A set of tools for extracting a fork oil seal, including several black cylindrical sleeves of different diameters and a long threaded rod with a conical tip.</p>
020922Y	Diagnosis Tool	 <p>A black plastic diagnosis tool with a blue label that reads "PADS". It has a rectangular shape with a notch on one end.</p>
020933Y	Flywheel extractor	 <p>A grey metal flywheel extractor tool, consisting of a long cylindrical body with a threaded end and a smaller cylindrical component.</p>
020994Y	Driven pulley lock	 <p>A metal driven pulley lock tool, featuring a circular opening and two vertical pins extending from the sides.</p>
020938Y	driving pulley check ring	 <p>A metal driving pulley check ring tool, which is a flat plate with a central hole and four vertical pins at the corners.</p>
020939Y	Flywheel retainer	 <p>A metal flywheel retainer tool, consisting of a curved metal piece with a central hole and a smaller cylindrical component.</p>
020941Y	Crankshaft timing adjustment tool	 <p>A metal crankshaft timing adjustment tool, featuring a long, flat metal bar with two vertical pins at the ends.</p>

**Stores code**

020942Y

**Description**

Piston protrusion check tool

---



# INDEX OF TOPICS

**MAINTENANCE**

**MAN**

## Maintenance chart

### FOR EUROPE VERSION

#### SCHEDULED MAINTENANCE TABLE

I: CHECK AND CLEAN, ADJUST, LUBRICATE OR REPLACE, IF NECESSARY C: CLEAN; R: REPLACE; A: ADJUST; L: LUBRICATE

\* Check level every 2,500 km

km x 1,000	1	5	10	15	20	25	30	EVERY 12 MONTH S	EVERY 24 MONTH S
Safety fasteners	I		I		I		I		
Spark plug			I		R		I		
Centre stand			I		I		I	L	L
Drive belt			R		R		R		
Throttle control	I		I		I		I	I	I
Rollers housing			I		I		I		
Diagnosis by tool	I	I	I	I	I	I	I	I	I
Air filter			R		R		R		
Engine oil filter	R		R		R		R	R	R
Valve clearance	A		A		A		A		
Clutch assembly					I				
Electrical system and battery	I	I	I	I	I	I	I		
Braking system	I		I		I		I	I	I
Cylinder cooling system						I		I	I
Brake fluid	I	I	I	I	I	I	I	I	R
Engine oil*	R	I	R	I	R	I	R	R	R
Hub oil			I		I		I	I	I
Headlight direction adjustment			I		I		I		
Brake pads		I	I	I	I	I	I	I	I
Sliding shoes / CVT rollers			I		R		I		
Engine oil pre-filter	C		C		C		C		
Tyre pressure and wear	I	I	I	I	I	I	I	I	I
Vehicle road test	I				I		I	I	I
Driven pulley - roller casings			I		L		I		
Suspensions			I		I		I	I	I
Steering	I		I		I		I	I	I
Front wheel bearing seal ring			L		L		L		
Pin_Rear drum brake set screw			L		L		L		
Transmission			L		L		L	I	I
Labour time (minutes)	50	30	140	30	140	30	140	60	60

### FOR ASIA-PACIFIC VERSION

#### SCHEDULED MAINTENANCE TABLE

I: CHECK AND CLEAN, ADJUST, LUBRICATE OR REPLACE, IF NECESSARY C: CLEAN; R: REPLACE; A: ADJUST; L: LUBRICATE

\* Check level every 2,500 km

\*\* Replace every 2 years

km x 1,000 or (months) maximum	1 (1)	5 (5)	10 (10)	15 (15)	20 (20)	25 (25)	30 (30)	35 (35)	40 (40)	45 (45)	50 (50)
Safety fasteners	I		I		I		I		I		I
Spark plug			I		R		I		R		I
Centre stand			I		I		I		I		I
Drive belt (125 cm <sup>3</sup> )			I		R		I		R		I
Drive belt (150 cm <sup>3</sup> )			R		R		R		R		R
Throttle control	I		I		I		I		I		I
Rollers housing			I		I		I		I		I
Diagnosis by tool	I	I	I	I	I	I	I	I	I	I	I
Air filter			R		R		R		R		R

km x 1,000 or (months) maximum	1 (1)	5 (5)	10 (10)	15 (15)	20 (20)	25 (25)	30 (30)	35 (35)	40 (40)	45 (45)	50 (50)
Engine oil filter	R		R		R		R		R		R
Valve clearance	A		A		A		A		A		A
Clutch assembly					I				I		
Electrical system and battery	I	I	I	I	I	I	I	I	I	I	I
Braking system	I		I		I		I		I		I
Cylinder cooling system						I					I
Brake fluid **	I	I	I	I	I	I	I	I	I	I	I
Engine oil*	R	I	R	I	R	I	R	I	R	I	R
Hub oil			I		I		I		I		I
Headlight direction adjustment			I		I		I		I		I
Brake pads		I	I	I	I	I	I	I	I	I	I
Sliding shoes / CVT rollers			I		R		I		R		I
Engine oil pre-filter	C		C		C		C		C		C
Tyre pressure and wear	I	I	I	I	I	I	I	I	I	I	I
Vehicle road test	I		I		I		I		I		I
Driven pulley - roller casings			I		L		I		L		I
Suspensions			I		I		I		I		I
Steering	I		I		I		I		I		I
Front wheel bearing seal ring			L		L		L		L		L
Pin_Rear drum brake set screw			L		L		L		L		L
Transmission			L		L		L		L		L
Labour time (minutes)	50	30	140	30	140	30	140	30	140	30	140

N.B.

**AT EACH SCHEDULED SERVICE, USE THE DIAGNOSTIC TOOL TO CHECK FOR ERRORS AND CHECK THAT ALL PARAMETERS ARE CORRECT. ENSURE THAT THE VEHICLE CALIBRATION IS UP TO DATE AFTER UPDATING THE DIAGNOSTIC TOOL.**

**CAUTION**

**AFTER THE PROVIDED MAINTENANCE PROGRAM IS INDICATED TO PROCEED WITH THE MAINTENANCE OF THE VEHICLE STARTING FROM THE SERVICE OF 5,000 Km (3,106 mi) OR 5 MONTHS.**

**Recommended Products**

Piaggio Group recommends the use of products from its Castrol official partner for the scheduled maintenance of its vehicles.

Only use lubricants and fluids which meet or exceed the performance characteristics specified.

This also applies when topping up only.



**FOR ASIA-PACIFIC VERSION**

**TABLE OF RECOMMENDED PRODUCTS**

Product	Description	Specifications
Engine oil 10W-40	Synthetic lubricant for four stroke engines (0°C < T < 45°C)	SAE 10W-40; JASO MB, MA, MA2; API SL
Transmission oil 80W-90	Lubricant for gearboxes and transmissions.	SAE 80W-90 API GL-4
DOT 4 brake fluid	Synthetic brake fluid.	SAE J 1703; FMVSS 116; ISO 4925; CUNA NC 956 DOT4
Lubricant grease	Lithium and medium fibre yellow brown coloured grease suitable for various uses.	ISO L-X-BCHA 3 - DIN 51 825 K3K -20
Water repellent spray grease	Water repellent pouring calcium spray grease.	White, soap base spray grease with NLGI 2 Calcium complex; ISO-L-XBCIB2

**FOR EUROPE VERSION**

**TABLE OF RECOMMENDED PRODUCTS**

Product	Description	Specifications
Engine oil 5W -40	Synthetic-based lubricant for four-stroke engines.	SAE 5W-40; JASO MA, MA2; API SL; ACEA A3
Transmission oil 80W-90	Lubricant for gearboxes and transmissions.	SAE 80W-90 API GL-4
DOT 4 brake fluid	Synthetic brake fluid.	SAE J 1703; FMVSS 116; ISO 4925; CU-NA NC 956 DOT4
Lubricant grease	Lithium and medium fibre yellow brown coloured grease suitable for various uses.	ISO L-X-BCHA 3 - DIN 51 825 K3K -20
Water repellent spray grease	Water repellent pouring calcium spray grease.	White, soap base spray grease with NLGI 2 Calcium complex; ISO-L-XBCIB2

**Spark plug**

To remove the spark plug, proceed as follows:

- Lift the saddle and undo the cover upper fixing screw from both sides of the vehicle.



- Undo the spark plug access cover lower fixing screws from both sides of the vehicle.



- Remove the spark plug access cover.



- Remove the spark plug cap.



- Undo the spark plug with the supplied wrench.



- Remove the spark plug from its housing. When refitting the plug, tighten it manually, being sure to insert it at the right angle. Use the wrench only to tighten it.

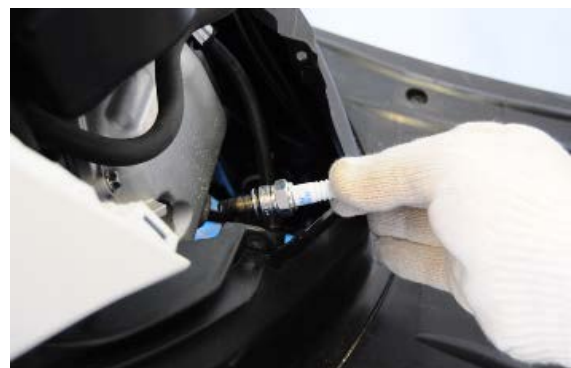

**CAUTION**



THE SPARK PLUG MUST BE REMOVED WHEN THE ENGINE IS COLD. THE USE OF SPARK PLUGS OF DIFFERENT THERMAL GRADE FROM THAT REQUIRED OR WITH INAPPROPRIATE THREADS MAY SERIOUSLY DAMAGE THE ENGINE.

**CAUTION**



FOLLOW THESE PROCEDURES VERY CAREFULLY TO AVOID ANY SEVERE DAMAGE THAT MAY BE CAUSED BY THE VERY POWERFUL IGNITION SYSTEM.

**CAUTION**



THE USE OF SPARK PLUGS OTHER THAN THOSE RECOMMENDED OR A SHIELDLESS SPARK PLUG CAP COULD CAUSE DISTURBANCES TO THE SYSTEM.

## Hub oil

## Check

### LEVEL CHECK

- Park the vehicle on level ground and centre stand.
- Undo the indicated screw and check for oil by inserting a shank/plug. The level should be just under the lower margin of the fill hole.
- With a cloth carefully clean the transmission crankcase.

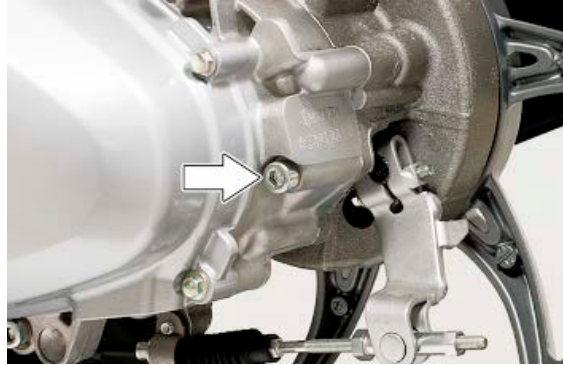

### WARNING



THE FUNCTION OF THE HUB WITH INSUFFICIENT HUB LUBRICATION OR WITH CONTAMINATED OR IMPROPER LUBRICANTS ACCELERATES THE WEAR AND TEAR OF THE MOVING PARTS AND CAN CAUSE SERIOUS DAMAGE.

## Replacement

- Remove the oil level check and filler screw.



- Prepare an adequately sized container.
- Unscrew the oil drainage plug and drain out all the oil.



- Wait for oil to drain completely and fit the screw back tightening it to the specified torque.

### Locking torques (N\*m)

Oil drain screw 14.7 - 16.7



- Fill with new oil from the top filler

### Characteristic

#### Hub oil quantity

325 cm<sup>3</sup>

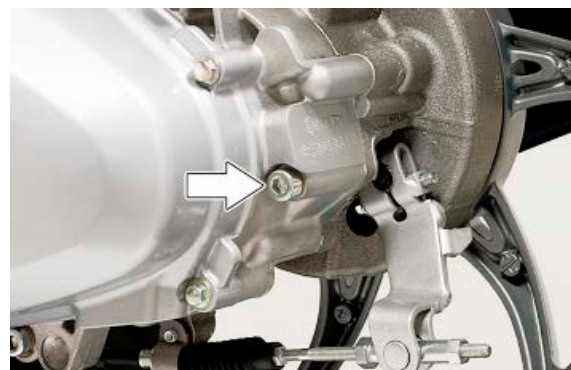

## Air filter

- move the screws indicated.

### CAUTION

WHEN TRAVELLING ON DUSTY ROADS, THE AIR FILTER MUST BE CLEANED MORE OFTEN THAN SHOWN IN THE SCHEDULED MAINTENANCE TABLE.

### WARNING



UTILIZZARE SEMPRE NUOVE GUARNIZIONI / O-RING; OGNI VOLTA CHE E' NECESSARIO SMONTARE LA SCATOLA FILTRO ARIA OPPURE SOSTITUIRE L'ELEMENTO FILTRANTE. LA MANCATA OSSERVANZA DELLA PRESENTE NOTA POTREBBE CAUSARE PROBLEMI DI TENUTA DELL'ELEMENTO FILTRANTE E CONSEGUENTE DANNO E USURA DEL MOTORE.

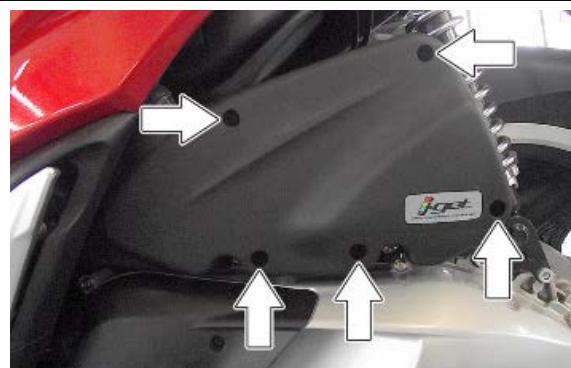

## Engine oil

In four-stroke engines, the engine oil is used to lubricate the timing elements, the bench bearings and the head-engine block-piston assembly. **An insufficient quantity of oil can cause serious damage to the engine.**

In all four stroke engines, the deterioration of the oil characteristics, or a certain consumption should be considered normal, especially if during the run-in period. Consumption levels in particular can be influenced by the conditions of use (e.g.: oil consumption increases when driving at "full throttle").

## Replacement

Change oil and replace filter as indicated in the scheduled maintenance table. The engine must be emptied by draining off the oil through the drainage plug of the mesh pre-filter, flywheel side; furthermore to facilitate oil drainage, loosen or remove the cap/dipstick. Once all the oil has drained through the drainage hole, unscrew the oil cartridge filter and remove it.



Make sure the pre-filter and drainage plug O-rings are in good conditions.

Lubricate them and refit the mesh filter and the oil drainage plug, screwing them up to the prescribed torque.

Refit the new cartridge filter being careful to lubricate the O-ring before fitting it.

Change the engine oil.

Since a certain quantity of oil still remains in the circuit, oil must be filled from oil dipstick/cover.

Then start up the vehicle, leave it running for a few minutes and switch it off: After about five minutes, check the level and, if necessary, top-up but never exceeding the **MAX** level reference mark. The cartridge filter must be replaced every time the oil is changed. Use new oil of the recommended type for topping up and changing purposes.

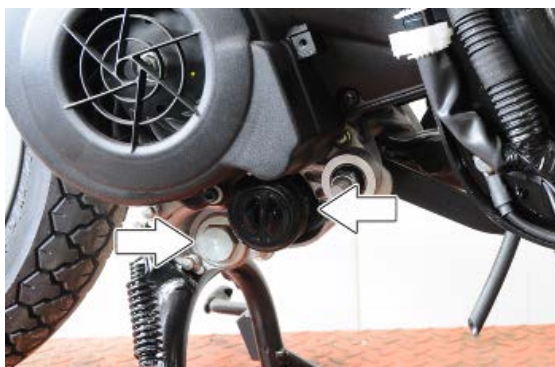
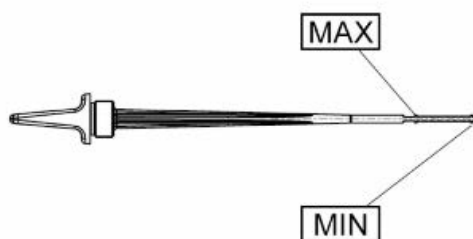

**N.B.**

**THE ENGINE MUST BE HOT WHEN THE OIL IS CHANGED.**

### Recommended products

**Engine oil 5W -40 Synthetic-based lubricant for four-stroke engines.**

SAE 5W-40; JASO MA, MA2; API SL; ACEA A3

### Characteristic

#### Engine oil quantity

1,340 cm<sup>3</sup> (of which 120 cm<sup>3</sup> in the filtering cartridge)

La sostituzione dell'olio e del filtro deve essere effettuata secondo quanto riportato nella tabella di manutenzione programmata. Il motore deve essere svuotato facendo fuoriuscire l'olio dal tappo di scarico del filtro a rete lato volano; inoltre per facilitare la fuoriuscita dell'olio, è opportuno allentare o

rimuovere il tappo/astina. Una volta che è terminata la fuoriuscita dell'olio dal foro di scarico, rimuovere il filtro e pulirlo.

**N.B.**

**THE ENGINE MUST BE HOT WHEN THE OIL IS CHANGED.**

### Recommended products

**Engine oil 10W-40 Synthetic lubricant for four stroke engines (0°C < T < 45°C)**

SAE 10W-40; JASO MB, MA, MA2; API SL

### Locking torques (N\*m)

**Engine oil drainage plug - Crankcase 25 - 28 Nm**

## Check

This operation must be carried out with the engine cold and following the procedure below:

- Place the vehicle on its centre stand and on flat ground.
- Undo cap/dipstick, dry it off with a clean cloth and reinsert it, **screwing down completely**.
- Remove the cap/dipstick again and check that the level is between the MIN and MAX reference marks; top-up, if required.

The MAX level mark indicates a quantity of around 1,340 cm<sup>3</sup> of engine oil. If the check is carried out after the vehicle has been used, and therefore with a hot engine, the level will be lower; in order to carry out a correct check, wait at least 10 minutes after the engine has been stopped so as to get the correct level.



### Engine oil top-up

The oil should be topped up after having checked the level and in any case by adding oil **without ever exceeding the MAX. level**.

## Engine oil filter

Change oil and replace filter as indicated in the scheduled maintenance table. Use new oil of the recommended type for topping up and changing purposes.

Make sure the pre-filter and drainage plug O-rings are in good conditions. Lubricate them and refit the mesh filter and the oil drainage plug, screwing them up to the prescribed torque. Refit the new cartridge filter being careful to lubricate the O-ring before fitting it. Change the engine oil.

**N.B.**

**THE ENGINE MUST BE HOT WHEN THE OIL IS CHANGED.**

### Recommended products

**Engine oil 5W -40 Synthetic-based lubricant for four-stroke engines.**

SAE 5W-40; JASO MA, MA2; API SL; ACEA A3

### Characteristic

#### Engine oil quantity

1,340 cm<sup>3</sup> (of which 120 cm<sup>3</sup> in the filtering cartridge)

## Oil pressure warning light

The vehicle is equipped with a tell-tale light on the instrument cluster that lights up when the key is turned to the «ON» position. However, this light should come off once the engine has been started.

**If the light turns on during braking, at idling speed or while turning a corner, it is necessary to check the oil level and the lubrication system.**

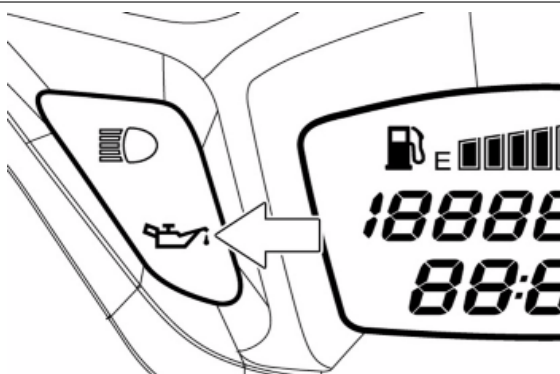

## Checking the valve clearance

- To check valve clearance, centre the reference marks of the timing system.
- Use a feeler gauge to check that the clearance between the valve and the register corresponds with the indicated values. When the valve clearance values, intake and exhaust respectively, are different from the ones indicated below, adjust them by loosening the lock nut and operating on the corresponding set screw, as shown in the figure.



### Characteristic

#### Valve clearance (cold engine)

intake: 0.08 mm outlet: 0.08 mm

## Top-up

---

## Braking system

---

### Level check

---

Proceed as follows:

- Rest the vehicle on its centre stand with the handlebars perfectly horizontal;
- Check the level of liquid with the related warning light «A».

A certain lowering of the level is caused by wear on the brake pads.



---

### Top-up

---

Proceed as follows:

- Remove the front handlebar cover.
- Remove the reservoir cap by loosening the two screws, remove the gasket and top-up using only the fluid specified without exceeding the maximum level.

**CAUTION**

**ONLY USE DOT 4-CLASSIFIED BRAKE FLUID.**

**CAUTION**



**AVOID CONTACT OF BRAKE FLUID WITH EYES, SKIN, AND CLOTHING. IN CASE OF ACCIDENTAL CONTACT, RINSE WITH WATER.**

**CAUTION**

**BRAKE CIRCUIT FLUID IS HIGHLY CORROSIVE: DO NOT LET IT COME INTO CONTACT WITH PAINTED PARTS.**

**CAUTION**

**BRAKE FLUID IS HYGROSCOPIC; THAT IS, IT ABSORBS MOISTURE FROM THE SURROUNDING AIR. IF THE CONTENT OF MOISTURE IN THE BRAKE FLUID EXCEEDS A CERTAIN VALUE, BRAKING WILL BE INEFFICIENT. NEVER USE BRAKE LIQUID FROM OPEN OR PARTIALLY USED CONTAINERS.**

**UNDER NORMAL CLIMATIC CONDITIONS, REPLACE FLUID AS INDICATED IN THE SCHEDULED MAINTENANCE TABLE.**

**N.B.**

**SEE THE BRAKING SYSTEM CHAPTER WITH REGARD TO THE CHANGING OF BRAKE FLUID AND THE BLEEDING OF AIR FROM THE CIRCUITS.**



## Headlight adjustment

Proceed as follows:

1. Position the vehicle in running order and with the tyres inflated to the prescribed pressure, onto a flat surface 10 m away from a half-lit white screen; ensure that the longitudinal axis of the vehicle is perpendicular to the screen;
2. Turn on the headlight and check that the boundary of the light beam projected onto the screen is not higher than  $\frac{9}{10}$  or lower than  $\frac{7}{10}$  of the distance between the centre of the headlight and the ground;
3. If this is not the case, adjust the headlight by operating the screw indicated.

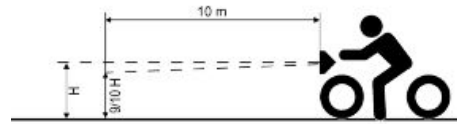

## Anti-evaporation system

### Canister inspection

The canister is essential to treat the hydrocarbons present in the volume of gas that escapes from the tank when there is an increase in internal pressure (tank heating induced by the cooling radiator, by the motor or by the external environment).

The volume of air is limited by the operation of the ventilation valve (Roll-over).

Although the amount of hydrocarbons coming from the tank is small enough to avoid the saturation of the canister, it is necessary to regenerate the activated carbon by means of a reversed flow of ambient air sucked by the engine.

These vacuums of pollution and carbon regeneration take place at each cycle of use of the vehicle.

To control the canister, it is necessary to proceed with its removal while keeping the 2 pipes connected.

- Shake the Canister and make sure there is no noise.
- Using a compressed air gun, blow alternately in 3 ducts and make sure that pressure does not build inside the canister.



- Check that the air flow is kept free and that no carbon residues escape out of any pipe.

If you detect noise, clogging or loss of carbon, replace the canister.

---

## Safety valve check

The cleaning of the canister is achieved via a controlled flow of air from the vacuum socket in the intake manifold.

To ensure that the engine works properly, it is necessary that the flow of air is not too intense, this is achieved by means of a restricted section 0.0354in (0.9 mm) formed in the socket on the intake manifold.

The relative connecting pipe with the canister, includes the installation of the safety valve.

This is a one-way valve which ensures the passage of air in the direction of the manifold when the control vacuum is greater than 2.9PSI (20kPa) (200mbar).

The vacuum of the engine at idle, causes a slight flow of air easily compensated by the idle speed adjustment parameters.

When the vehicle is stopped, the safety valve will be closed due to the lack of control vacuum therefore, any expansion of the fuel tank, will not cause pollution of the intake manifold, and then cause flooding of the engine.

---

To control the valve, it is preferable to it, alternatively just access the manifold side pipe.

- Connect the MITY-VAC pump on the engine side duct.
- Select the pump command on the "vacuum" position, then slowly apply vacuum up to the valve threshold check opening.



If you detect different pressures, replace the valve.

**Note:** An excessively high opening vacuum value impedes the active carbon regeneration process; vice versa, an opening vacuum that is too low, increases the flow of air to the engine causing the thinning of idle.

### Characteristic

#### Standard opening vacuum

(2.90-3.77)PSI (20-26)kPa (200-260)mbar

---

## Roll-over valve check

The valve must enable the following results:

- Aeration of the tank while riding (the ambient air enters the tank in relation to the volume of fuel used).
- Pressurisation of the tank (while riding or during a break, you may experience increases in the temperature inside the tank. The valve must pressurize the tank to limit the escape of fuel vapour to the canister).
- Prevent pollution of the canister with the liquid fuel (in case of fall of the vehicle, the valve must block the connection with the canister).

To control the valve, it is necessary to remove it from the vehicle.

For the check, it is planned to use a MITY-VAC pump and a piece of tube, then proceed as follows:

- Connect the MITY-VAC pump to the lower joint of the safety valve (white).
- Select the "vacuum" control position and keeping the valve in the vertical axis, check that it is possible to intake air without movements of the gauge needle.
- Switch the control of the pump to "pressure" and, keeping the valve in the vertical axis, check that it is possible to pressurise the valve up to values slightly below 1.45PSI (~0.87PSI) 10kPa (~6kPa) 100mbar (~60mbar).

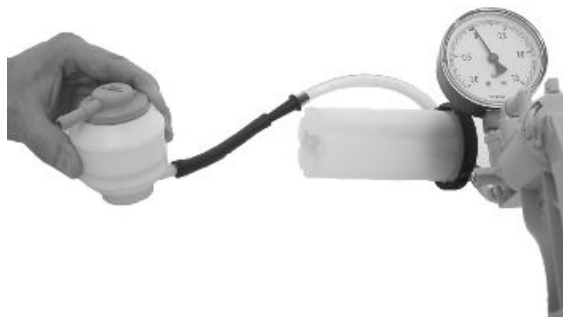

**Note:** The calibration pressure is easily identifiable as when this pressure is reached, the valve vents the air with a small sound.

- Position the valve in the horizontal axis and check that you can pressurise it to values well above the setting pressure (e.g. 7.25PSI (50 kPa) (0.5bar) without guaranteeing the maintenance).

If you detect abnormal behaviour, replace the valve.

**Note:** Any malfunction of the valve may cause deformation of the fuel tank or compromise canister function.

---

## INDEX OF TOPICS

**T**ROUBLESHOOTING

**RIC GUA**

---

## Engine

---

### Poor performance

#### POOR PERFORMANCE

Possible Cause	Operation
Air filter blocked or dirty	Remove the sponge, wash with water and car shampoo, soak with specific oil for foam filter treatment. Press with your hand without squeezing, allow it to drip dry and refit
Excessive drive belt wear	Check it and replace, if necessary
Lack of compression: parts, cylinder and valves worn	Replace the worn parts
Engine oil level exceeds maximum	Check for causes and fill to reach the correct level
Excess of scales in the combustion chamber	Descale the cylinder, the piston, the head and the valves
Incorrect timing or worn timing system elements	Time the system again or replace the worn parts
Silencer obstructed	Replace
Inefficient automatic transmission	Check the rollers and the pulley movement, replace the damaged parts and lubricate the movable guide of the driven pulley with grease
Wrong valve adjustment	Adjust the valve clearance properly
Overheated valves	Remove the head and the valves, grind or replace the valves
Valve seat distorted	Replace the head unit
Worn cylinder, Worn or broken piston rings	Replace the piston cylinder assembly or just the piston rings

### Starting difficulties

#### START-UP PROBLEMS

Possible Cause	Operation
Flat battery	Check the state of the battery. If it shows signs of sulphation, replace it and bring the new battery into service by charging it for not more than ten hours at a current of 1/10 of the capacity of the battery itself.
Faulty spark plug	Replace the spark plug
Incorrect valve sealing or valve adjustment	Inspect the head and/or restore the correct clearance
Starter motor and start-up system fault	Check starter motor.
Altered fuel characteristics	Drain off the fuel no longer up to standard; then, refill
Air filter obstructed or dirty	Remove the sponge, wash with water and car shampoo, soak with specific oil for foam filter treatment. Press with your hand without squeezing, allow it to drip dry and refit
Fuel pump fault	Check the pump.

### Excessive oil consumption/Exhaust smoke

#### EXCESSIVE CONSUMPTION

Possible Cause	Operation
Wrong valve adjustment	Adjust the valve clearance properly
Overheated valves	Remove the head and the valves, grind or replace the valves
Misshapen/worn valve seats	Replace the head unit
Worn cylinder, Worn or broken piston rings	Replace the piston cylinder assembly or piston rings
Worn or broken piston rings or piston rings that have not been fitted properly	Replace the piston cylinder unit or just the piston rings
Oil leaks from the couplings or from the gaskets	Check and replace the gaskets or restore the coupling seal
Worn valve oil seal	Replace the valve oil seal
Worn valve guides	Check and replace the head unit if required

## Insufficient lubrication pressure

### LOW LUBRICATION PRESSURE

Possible Cause	Operation
By-Pass remains open	Check the By-Pass and replace if required. Carefully clean the By-Pass area.
Oil pump with excessive clearance	Perform the dimensional checks on the oil pump components
Oil filter too dirty	Replace the cartridge filter
Oil level too low	Restore the level adding the recommended oil type

## Transmission and brakes

## Clutch grabbing or performing inadequately

### IRREGULAR CLUTCH PERFORMANCE OR SLIPPAGE

Possible Cause	Operation
Slippage or irregular functioning	Check that there is no grease on the masses. Check that the faying surface between the clutch masses and the clutch housing is mainly in the middle and with equivalent specifications on the three masses. Check that the clutch housing is not scored or worn abnormally.

## Insufficient braking

### INEFFICIENT OR NOISY BRAKING

Possible Cause	Operation
Worn brake pads or shoes	Replace the brake pads or shoes and check for brake disk or drum wear conditions.
Front brake disk loose or deformed	Check the brake disc screws are locked; use a dial gauge and a wheel mounted on the vehicle to measure the axial shift of the disc.
Air bubbles inside the hydraulic braking system	Carefully bleed the hydraulic braking system, (there must be no flexible movement of the brake lever).
Fluid leakage in hydraulic braking system	Failing elastic fittings, plunger or brake pump seals, replace
Excessive clearance in the rear brake control cable	Adjust the clearance with the appropriate adjuster located on the back part of the crankcase.

## Brakes overheating

### BRAKES OVERHEATING

Possible Cause	Operation
Rubber gaskets swollen or stuck.	Replace gaskets.
Compensation holes on the pump clogged.	Clean carefully and blast with compressed air.
Brake disc slack or distorted	Check the brake disc screws are locked; use a dial gauge and a wheel mounted on the vehicle to measure the axial shift of the disc.
Defective piston sliding.	Check calliper and replace any damaged part.

## Electrical system

## Battery

### BATTERY

Possible Cause	Operation
Battery	The battery is the electrical device in the system that requires the most frequent inspections and thorough maintenance. If the vehicle is not used for some time (1 month or more) the battery needs to be recharged periodically. The battery runs down completely in the course of 5 - 6 months. If the battery is fitted on a motorcycle, be careful not to invert the connections, keeping in mind that the black ground wire is connected to the negative terminal while the red wire is connected to the terminal marked+. Follow the instructions in the ELECTRICAL SYSTEM chapter for the recharging of the batteries.

## Steering and suspensions

### Heavy steering

#### STEERING HARDENING

Possible Cause	Operation
Steering hardening	Check the tightening of the top and bottom ring nuts. If irregularities continue in turning the steering even after making the above adjustments, check the seats in which the ball bearings rotate: replace them if they are recessed or if the balls are flattened.

### Excessive steering play

#### EXCESSIVE STEERING CLEARANCE

Possible Cause	Operation
Excessive steering clearance	Check the tightening of the top ring nut. If irregularities continue in turning the steering even after making the above adjustments, check the seats in which the ball bearings rotate: replace if they are recessed.

### Noisy suspension

#### NOISY SUSPENSION

Possible Cause	Operation
Noisy suspension	If the front suspension is noisy, check: that the shock absorber in the stems works properly and the steering ball bearings are in good condition. Finally, check the locking torque of the wheel axle nut, the brake calliper and the disc. Check that the swinging arm connecting the engine to the frame and the rear shock absorber work properly.

### Suspension oil leakage

#### OIL LEAKAGE FROM SUSPENSION

Possible Cause	Operation
Faulty or broken seals	Replace the shock absorber. Check the condition of wear of the steering covers and the adjustments.



# INDEX OF TOPICS

ELECTRICAL SYSTEM

IMP ELE

Components arrangement

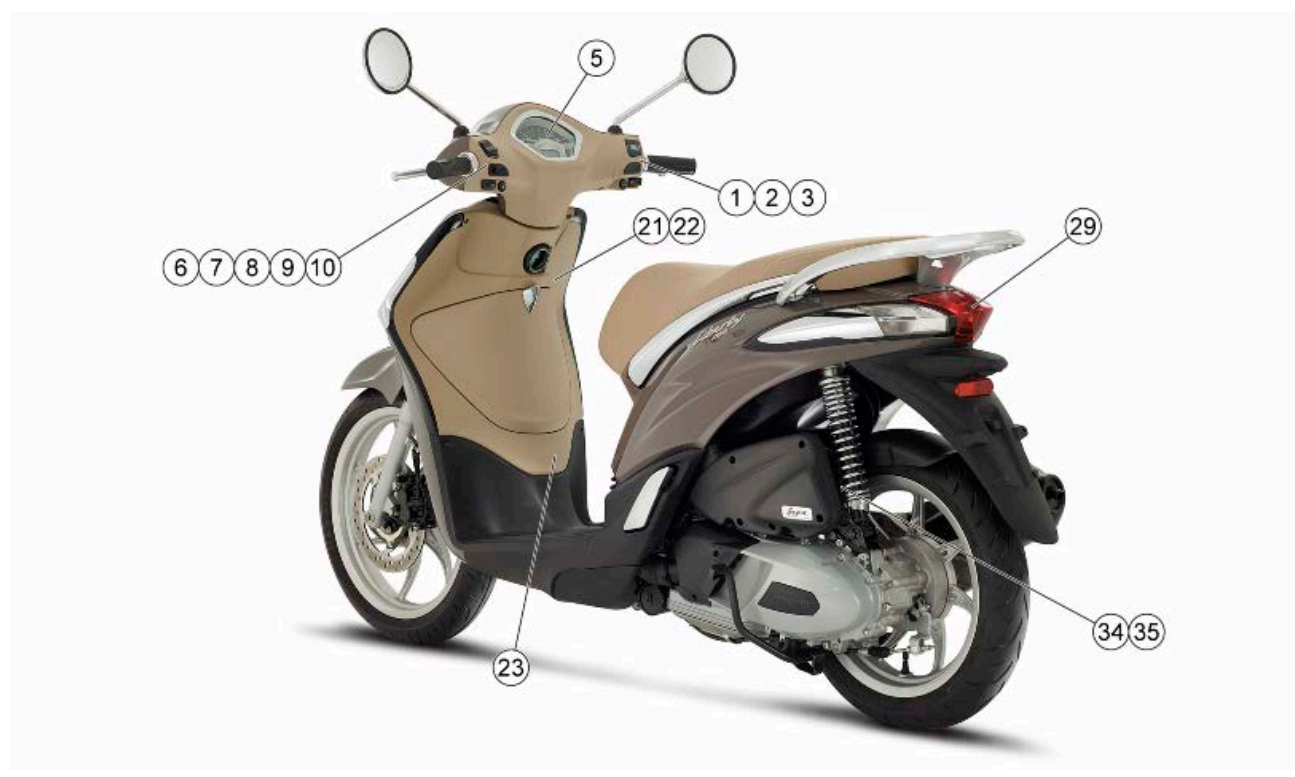

1. Right stop button.

2. MODE button

3. Starter button

Remove the rear handlebar to reach it.



4. Headlight

Remove the front handlebar to reach it.

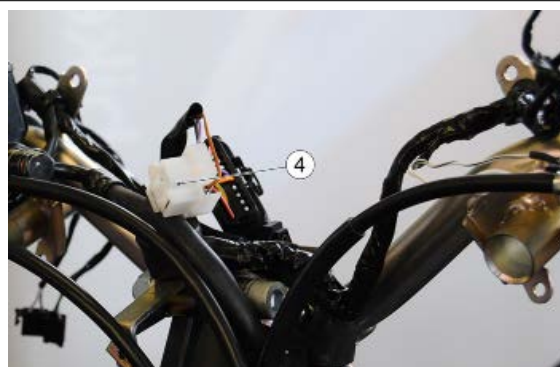

5. Instrument cluster

Remove the rear handlebar to reach it.

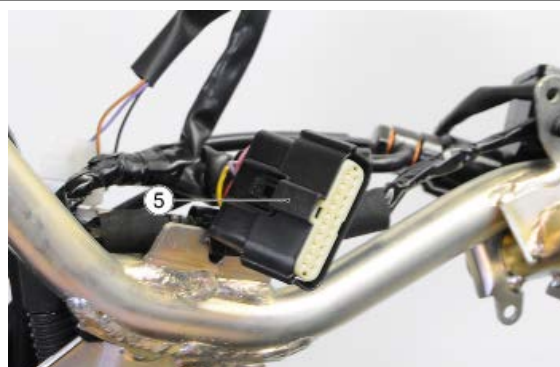

6. Left stop button

7. Horn button

8. Turn signal switch

9. Light switch

10. Saddle release switch

Remove the rear handlebar to reach it.



**11.** Voltage regulator

**12.** Ignition switch

**13.** ABS control unit

Remove the shield to reach it.

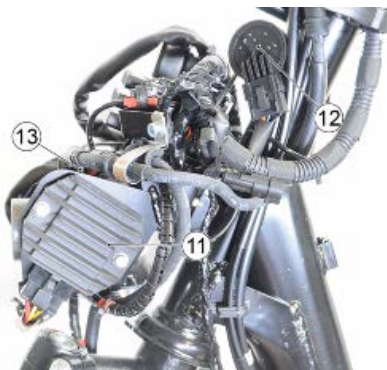

**14.** Left front daylight running light

**15.** Left front turn indicator.

**16.** USB pre-installation

Remove the shield to reach it.

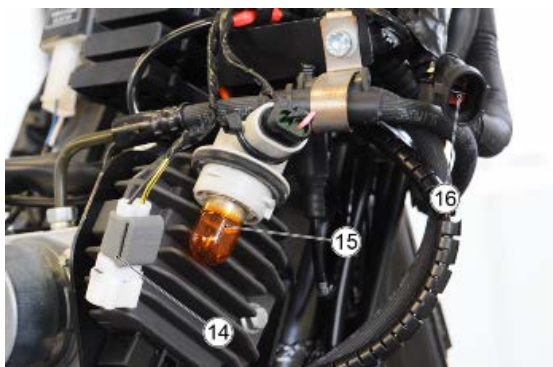

**17.** ABS sensor

Remove the shield to reach the connector.



**18.** Ignition/injection ECU

**19.** Fuses.

**20.** Direction indicator device

Remove the shield to reach it.



- 21.** Right turn indicator light  
**22.** Right front daylight running light  
Remove the shield to reach it.

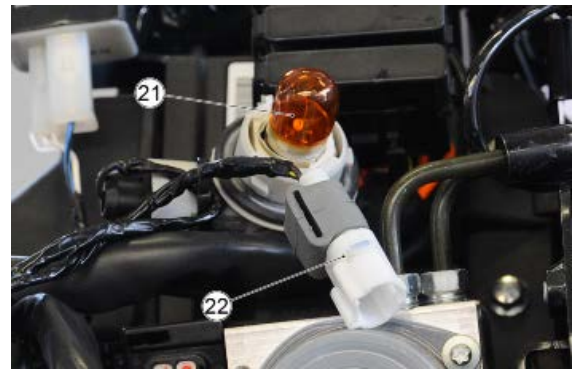

- 23.** Horn  
Remove the leg shield back plate to reach it.



- 24.** Wiring for accessories - connector  
**25.** Roll-over sensor  
Remove the leg shield back plate to reach it.



- 26.** Saddle opening actuator  
Remove the leg shield back plate to reach it.

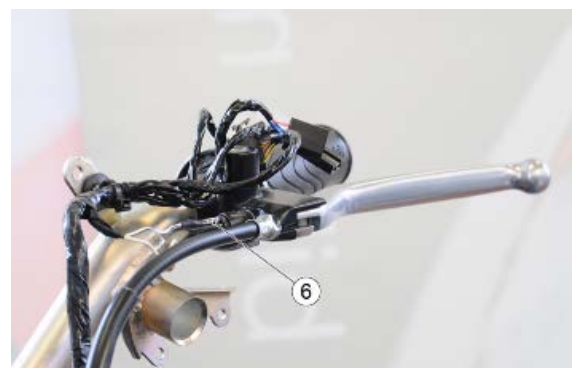

**27. Fuel gauge**

Remove the helmet compartment to reach it.

**28. Fuel pump**

Remove the helmet compartment to reach it.

**29. Taillight**

Remove the rear light assembly to reach it.

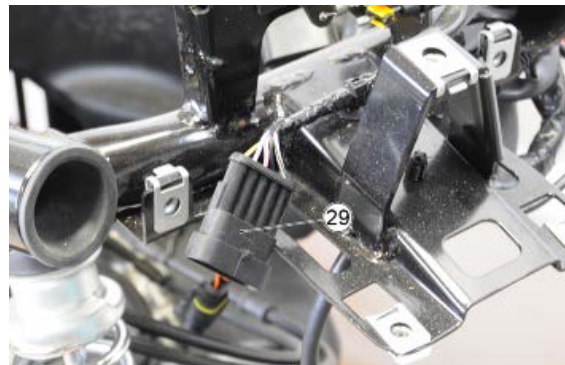
**30. Battery****31. Starter relay****32. Fuses****33. Diagnostic socket**

Remove the battery compartment cover to reach it.



---

**34. Lambda probe**



---

**35. Flywheel**

Remove the protection to reach it.



---

**36. Starter motor**

**37. Injector**

**38. Engine temperature sensor**

**39. Engine idle speed adjustment valve**

**40. Throttle position sensor**

**41. Coil**

Remove the helmet compartment to reach it.



## Instrument panel

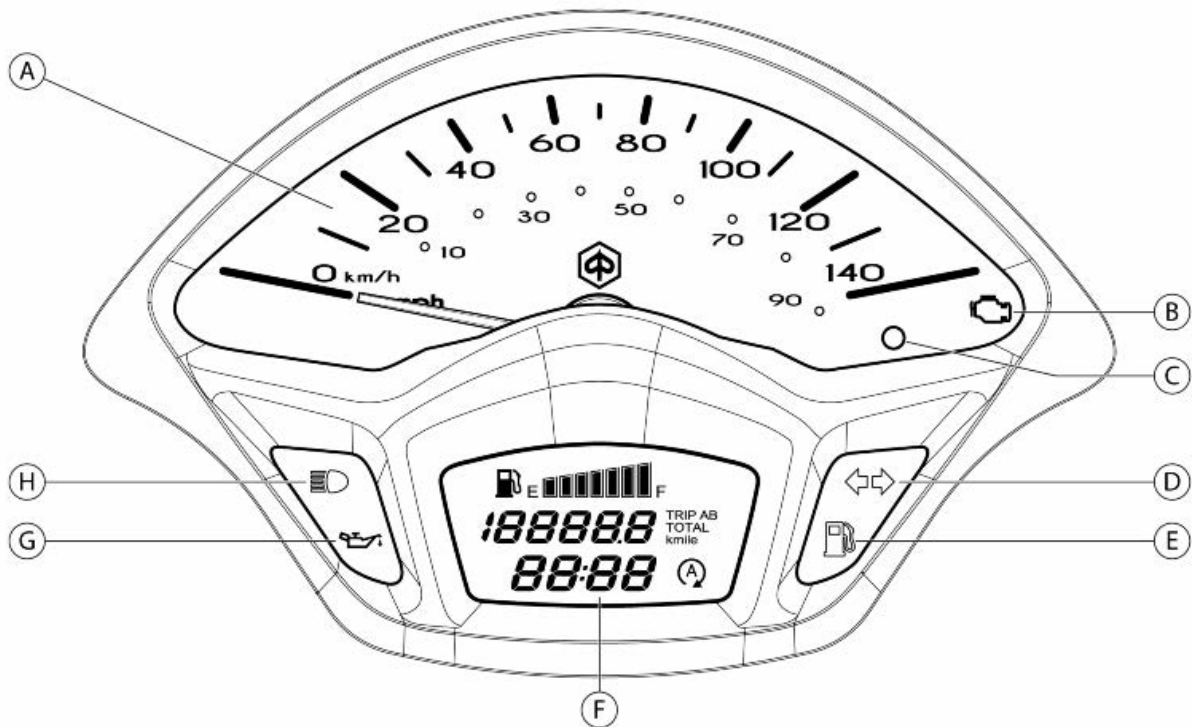

- A = Speedometer
- B = Engine control warning light
- C = Immobilizer warning light
- D = Turn indicator warning light
- E = Low fuel warning light
- F = Digital display
- G = Low oil pressure warning light
- H = High-beam warning lights on

The «**MODE**» key, located on the right side of the handlebar, allows to:

- alternate the display of the total or trip odometer with short pressures;
- alternate the trip odometer when shown, with a long pressure;
- access the time adjusting mode, when the total odometer is shown, with a long pressure;
- set the measuring unit of the odometer between kilometres «**Km**» or miles «**mile**»; to proceed with this setting, display the total odometer and put the ignition switch to «**OFF**». Keep the «**MODE**» key



pressed and put the ignition switch to «**ON**», release within **2 seconds** the «**MODE**» key.

Turning the ignition switch to «**ON**», the digital display will show:

- the fuel level in the tank.

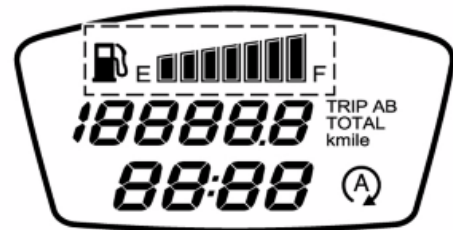

- the current hour and minutes in format «hh:mm».

Set the correct time as described in the paragraph «Set functions hours/minutes».

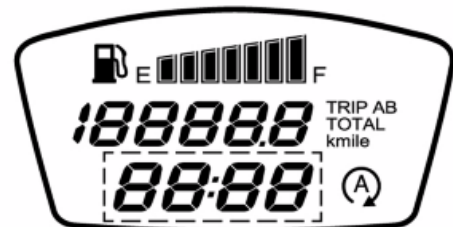

### HOUR/MINUTE FUNCTION SETTING

To set or adjust the time, with vehicle running or with key inserted in «**ON**» position, proceed as follows:

- press the «**MODE**» key for a couple of seconds to display the total odometer;
- with a long press of the «**MODE**» key, the number of hours flashes in "hh" format;
- adjust the hour by short pressing the **MODE** key;
- with a long press, the set value is confirmed (or present value if not modified) and the minutes value, in format «mm» starts flashing.
- adjust the minutes by short pressing the **MODE** key;
- with a long press, the set value is confirmed (or present value if not modified) and the clock adjustment is exited;

If, during the adjustment procedure, the «**MODE**» key is not pressed for a time longer than ten seconds, the procedure is interrupted and clock value remains the same as before the adjustment; repeat the adjustment operations.

#### WARNING



**FOR SAFETY REASONS THE TIME SETTING IS ONLY POSSIBLE WITH THE VEHICLE AT A STANDSTILL.**

#### WARNING



**DISCONNECTING THE BATTERY CABLES WILL RESULT IN A RESET OF THE CLOCK**

- Press the «**MODE**» key located on the handlebar for a couple of seconds to display the total and trip odometer (TRIP A and TRIP B). During the display of the trip odometer «**TRIP A**» or «**TRIP B**», with a long press of the «**MODE**» key, the trip values are reset.

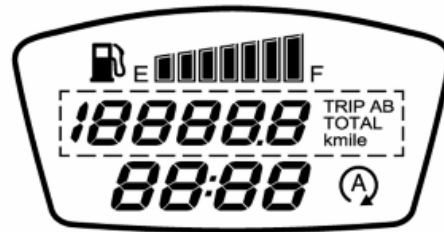
**N.B.**

THE FOLLOWING ARE DEFINED WHEN NAVIGATING THE DISPLAY:

- «**BRIEF PRESS**»: PRESSING THE BUTTON INDICATED FOR LESS THAN HALF A SECOND;
- «**PROLONGED PRESS**»: PRESSING THE BUTTON INDICATED FOR MORE THAN THREE SECONDS.

## Ground points

Frame ground.



Frame engine-ground.



## Electrical system installation

Front side

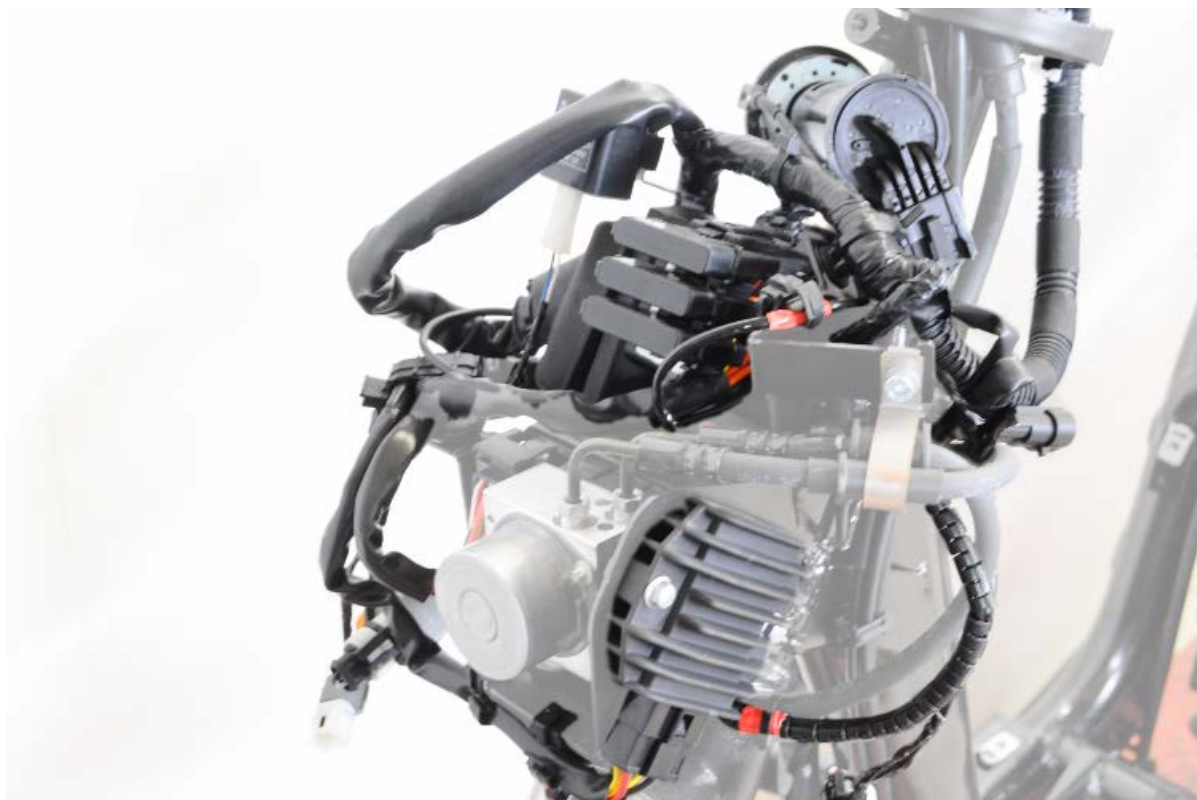

**Back side**

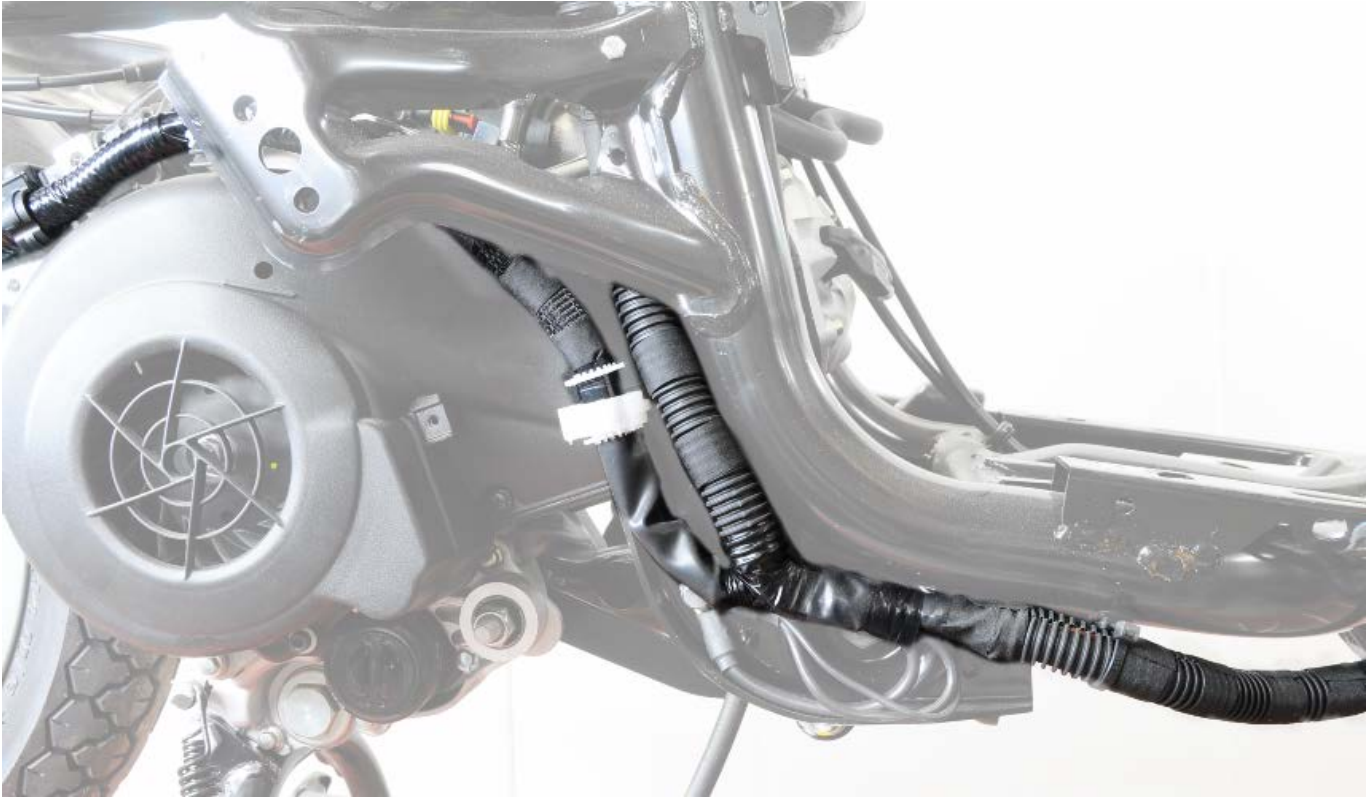



---

**Checks and inspections**

---

---

## Immobiliser

The electronic ignition system is controlled by the control unit with the integrated Immobilizer system. The immobilizer is an antitheft system which allows the vehicle to function only if it is activated by means of the coded keys that the control unit recognises. The code is integrated in a transponder in the key block. This allows the driver clear operation without having to do anything other than just turning the key. The Immobilizer system consists of the following components:

- control unit
- immobilizer antenna
- master and service keys with built-in transponder
- H.V. coil
- diagnosis LED

The diagnosis LED also works as a theft-deterrent blinker. This function is activated every time the ignition switch is turned to «**OFF**», and it remains active 48 hours so as not to affect the battery charge.

When the ignition switch is turned to «**ON**», the deterring blinker function is deactivated. Subsequently, a flash confirms the switching to «**ON**». The duration of the flash depends on the programming of the electronic control unit.

If the LED is off regardless of the position of the ignition switch and/or the instrument panel is not initiated, check if:

- there is battery voltage
- fuse No. 01 and fuse No. 02 efficiency
- there is power to the control unit as specified below:

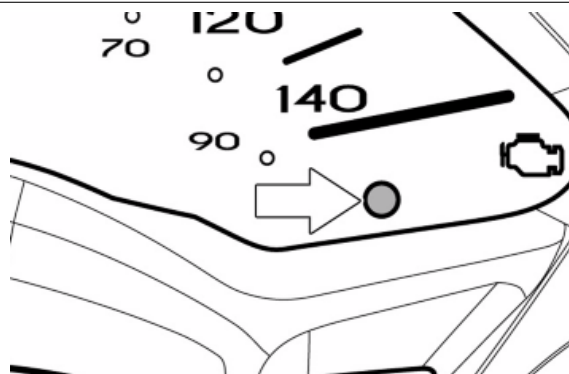

**With the ignition key set to « OFF »:**

- there is battery voltage between terminals 5-19 and terminal 5-frame ground (fixed power supply). If there is no voltage check that fuses no. 01, 02 and relative wiring harnesses are in working order.

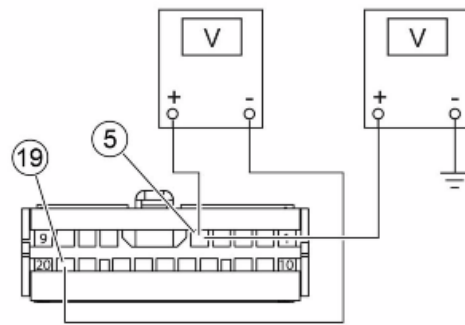
**With the ignition key set to « ON »:**

- there is battery voltage between terminals 20-19 and terminal 20-frame ground (fixed power supply). If there is no voltage, check the ignition switch contacts, that fuse no. 01, 04 and relative wiring harnesses are in working order.

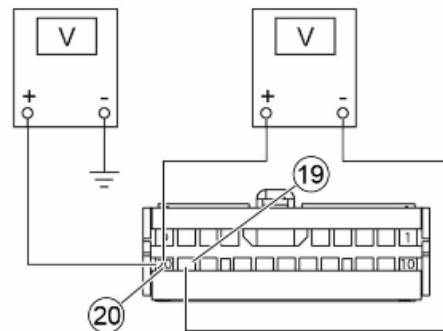
**Virgin circuit**

When the ignition system is not encrypted, any key will start the engine but limited to 2,000 rpm. The keys can only be recognised if the control unit has been programmed properly.

The data storage procedure for a previously un-programmed control unit provides for the recognition of the red key (master key) as the first key to be stored to memory: this becomes particularly important because it is the only key that enables the control unit to be wiped clean and reprogrammed for the memorisation of the service keys.

The Master and service keys must be used to code the system as follows:

- Insert the Master key, turn it to «ON» and keep this position for two seconds (lower and upper limits 1 - 3 seconds).
- Insert the blue key and set to «ON» for 2 seconds.
- If you have copies of the key, repeat the operation with each key.

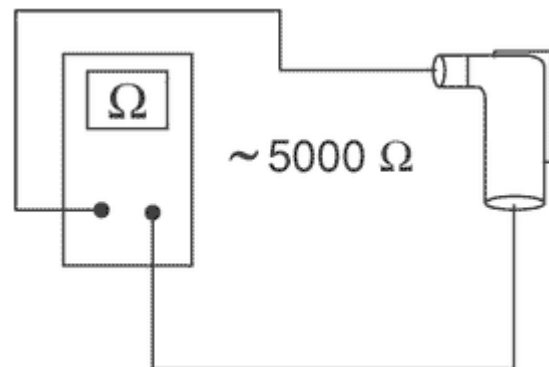

- Insert the MASTER key again and turn it to «ON» for 2 seconds.

The maximum time to change keys is 10 seconds. A maximum of 7 service keys (blue) can be programmed at one time.

It is essential to adhere to the times and the procedure. If you do not, start again from the beginning.

Once the system has been programmed, master key transponder, decoder and control unit are strictly matched.

With this link established, it is now possible to encode new service keys, in the event of losses, replacements, etc.

Each new programming deletes the previous one so, in order to add or eliminate keys, you must repeat the procedure using all the keys you intend to keep using.

If a service key becomes uncoded, the efficiency of the high voltage circuit shielding must be thoroughly inspected. In any case it is advisable to use resistive spark plugs.

### Characteristic

#### Shielded cap resistance

~ 5,000  $\Omega$

## Diagnostic codes

The Immobilizer system is tested each time the Ignition switch is turned from «OFF» to «ON». During this diagnosis phase a number of control unit statuses can be identified and various light codes displayed. Regardless of the code transmitted, if at the end of the diagnosis the LED remains off permanently, the ignition is enabled. If, however, the LED remains on permanently, it means the ignition is inhibited:

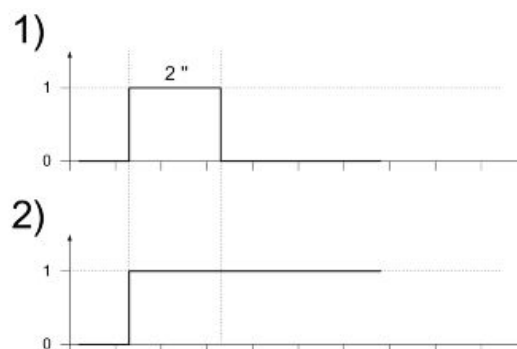

**1. Previously unused control unit - key inserted:**

a single 2 second flash is displayed, after which the LED remains off permanently. The keys can be stored to memory, the vehicle can be started but with a limitation imposed on the number of revs.

**2. Previously unused control unit - transponder absent or cannot be used:**

the LED is on permanently. In this condition no operations are possible including the start up of the vehicle.

**3. Programmed control unit - the service key in**

**(normal condition of use):** a single 0.7-second flash is displayed, after which the LED remains off steadily. The engine can be started.

**4. Programmed control unit - Master key in:**

a 0.7-sec flash is displayed followed by the LED remaining off for 2 sec and then by short 0.46-sec flashes, the same number of times as there are keys stored in the memory including the Master key. When the diagnosis has been completed, the LED remains permanently OFF. The engine can be started.

**5. Programmed control unit - fault detected:** a light code is displayed according to the fault detected, after which the LED remains on steadily. The engine cannot be started. The codes that can be transmitted are:

- 1-flash code
- 2-flash code
- 3-flash code

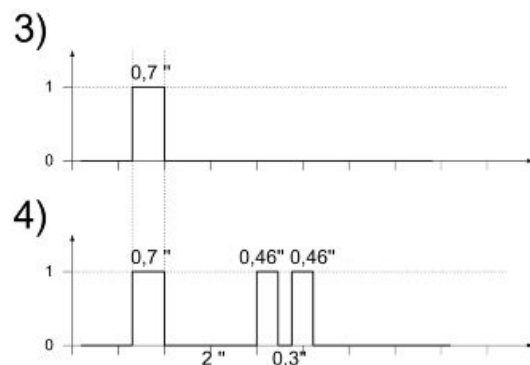

## Diagnostic code - 1 flash

A one-flash code indicates a system where the serial line is not present or is not detected. Check the Immobilizer antenna wiring and change it if necessary.

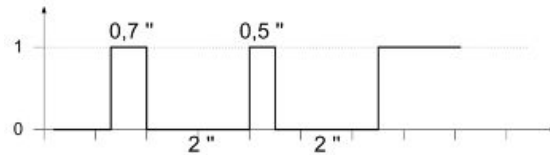

## Diagnostic code - 2 flashes

A two-flash code shows a system where the control unit does not show the transponder signal. This might depend on the inefficiency of the Immobilizer antenna or the transponder.

Turn the switch to ON using several keys: if the code is repeated even with the Master key, check the antenna wiring and change it if necessary. If this is not the case, replace the defective key and/or reprogram the control unit. Replace the control unit if the problem continues.

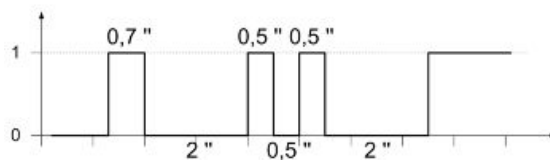

## Diagnostic code - 3 flashes

A three-flash code indicates a system where the control unit does not recognise the key. Turn the switch to ON using several keys: if the error code is repeated even with the Master key, replace the control unit. If this is not the case, reprogram the decoder.

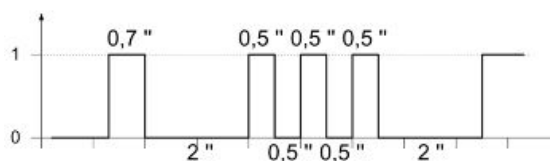

## Battery recharge circuit

The charging circuit consists of three-phase alternator and a permanent magneto flywheel.

The alternator is directly connected to the voltage regulator.

In turn, the voltage regulator is directly connected to the ground connection and to the battery positive terminal passing through the 20A No. 01 protection fuse.

The three-phase alternator provides good recharge power and at low revs a good compromise is achieved between generated power and idle stability.

---

## Stator check

### Checking the stator windings

#### WARNING

**THE CHECK-UP CAN BE MADE WITH THE STATOR PROPERLY INSTALLED.**

- Remove the protection of the connector.
- Disconnect the connector between stator and regulator with the three yellow cables as shown in the picture.
- Measure the resistance between each of the yellow terminals and the other two.

### Electric Characteristics

#### Resistance:

0.2 - 1  $\Omega$

- Check that there is insulation between the each yellow cable and the ground.
- If values are incorrect, replace the stator.



---

## Recharge system voltage check

### Look for any leakage

- 1) Access the battery by removing the specific cover.
- 2) Check that the battery does not show signs of losing fluid before checking the output voltage.
- 3) Turn the ignition key to position OFF, connect the terminals of the tester between the negative pole (-) of the battery and the black cable and only then disconnect the black cable from the negative pole (-) of the battery.
- 4) With the ignition key always at OFF, the reading indicated by the ammeter must be  $\leq 0.5$  mA.

### Charging current check

#### WARNING

**BEFORE CARRYING OUT THE CHECK, MAKE SURE THAT THE BATTERY IS IN GOOD WORKING ORDER.**

- 1) Place the vehicle on its centre stand.
- 2) With the battery correctly connected to the circuit, place the multimeter leads between the battery terminals..

3) Start the engine, ensure that the lights are all off (lights switch moved to the right), increase the engine speed and at the same time measure the voltage.

**FOR VEHICLES EQUIPPED WITH A VOLTAGE REGULATOR "CONTROLLED" BY THE ENGINE CONTROL UNIT, MEASURE THE VOLTAGE AT THE BATTERY TERMINALS WITH THE ENGINE IDLING AND AFTER A FEW MINUTES OF THE ENGINE RUNNING BECAUSE THE VOLTAGE COULD DECREASE AT START UP AND AS THE ENGINE RPM INCREASES.**

**Electric Characteristics**

**Voltage ranging between 14.0 and 15.0V at 5,000 rpm.**

**Maximum current output check**

- With engine off and panel set to "ON" turn on the lights, by moving the lights switch to the left, and let the battery voltage set to 12V.
  - Connect a ammeter clamp to the recharge positive pole (Red-Black cable) in output from the regulator.
  - Keep the lights on and start the engine, bring it to normal speed and read the values on the ammeter.
- With an efficient battery a value must be detected: > 20A

**VOLTAGE REGULATOR/RECTIFIER**

Specification	Desc./Quantity
Type	Non-adjustable three-phase transistor
Voltage	14 - 15V at 5,000 rpm with lights off

**See also**

Battery

**Starter motor**

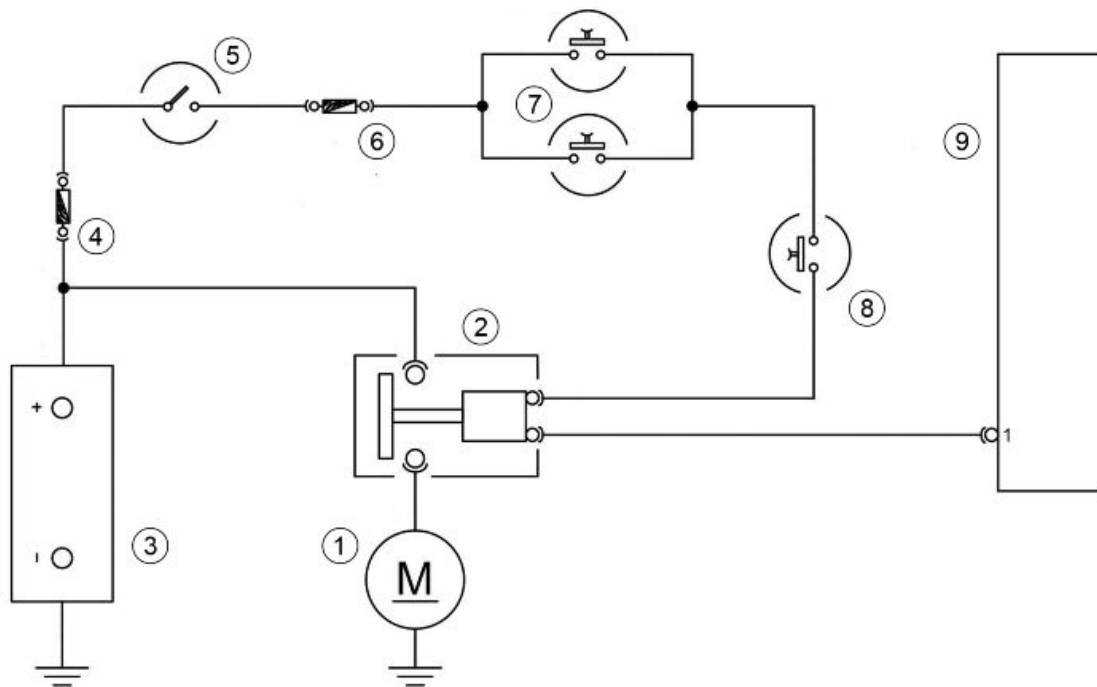

## KEY

1. Starter motor
2. Starter relay
3. Battery
4. Fuse No. 1
5. Ignition switch contacts
6. Fuse No. 5
7. Stop buttons
8. Starter button
9. Injection ECU

## WARNING

**ALL CONTINUITY TESTS MUST BE CARRIED OUT WITH THE CORRESPONDING CONNECTORS DISCONNECTED.**

- 1) Check fuses No. 01 and No. 05.
  - 2) Check ignition switch contacts.
  - 3) Check the contacts of the stop buttons and the starter button.
  - 4) Check with the ignition switch «**ON**», brake engaged and start button pressed, the presence of voltage between the Purple cable of the starter relay and ground, otherwise check the wiring harness.
  - 5) Check the starter relay.
  - 6) Check that the Red cable between the battery and the starter relay is not interrupted. Also check continuity between the latter and the starter motor.
  - 7) Check the starter motor ground connection.
-

## Horn control

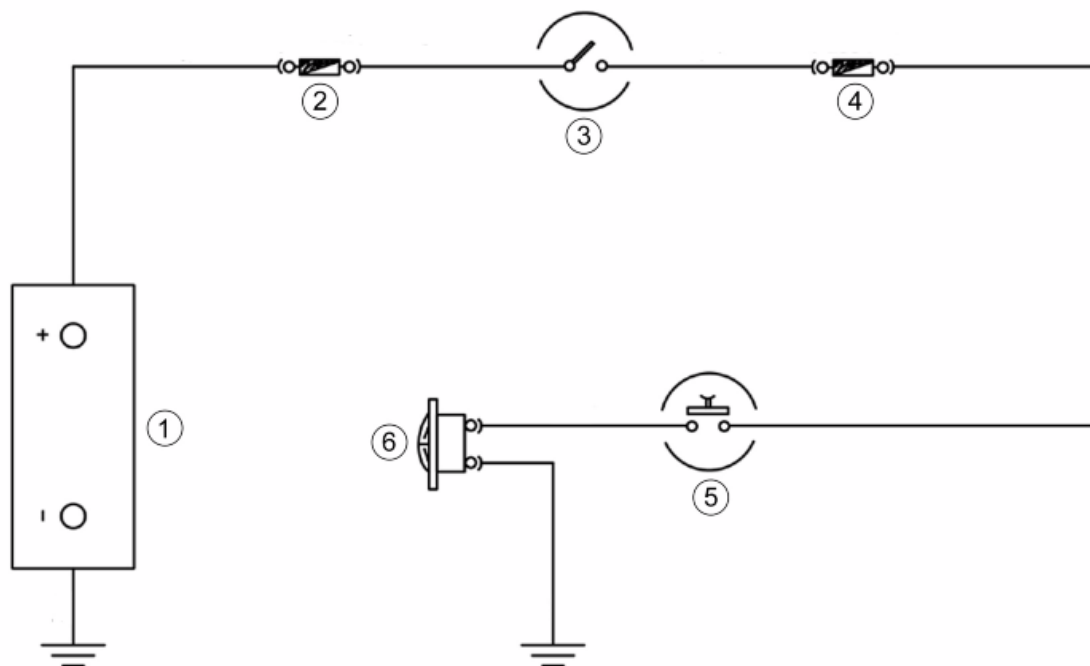

### KEY

1. Battery
2. Fuse No. 1
3. Ignition switch contacts
4. Fuse No. 5
5. Horn button
6. Horn

### WARNING

**ALL CONTINUITY TESTS MUST BE CARRIED OUT WITH THE CORRESPONDING CONNECTORS DISCONNECTED.**

- 1) Check fuses No. 01 and No. 05.
- 2) Check the ignition switch and horn button contacts.
- 3) With the ignition switch set to «ON» and the horn button pressed, check if there is voltage between the Grey-Black cable of the horn device and the ground connection. If there is not, check the wiring harnesses.
- 4) Check the horn device ground connection.

## Turn signals system check

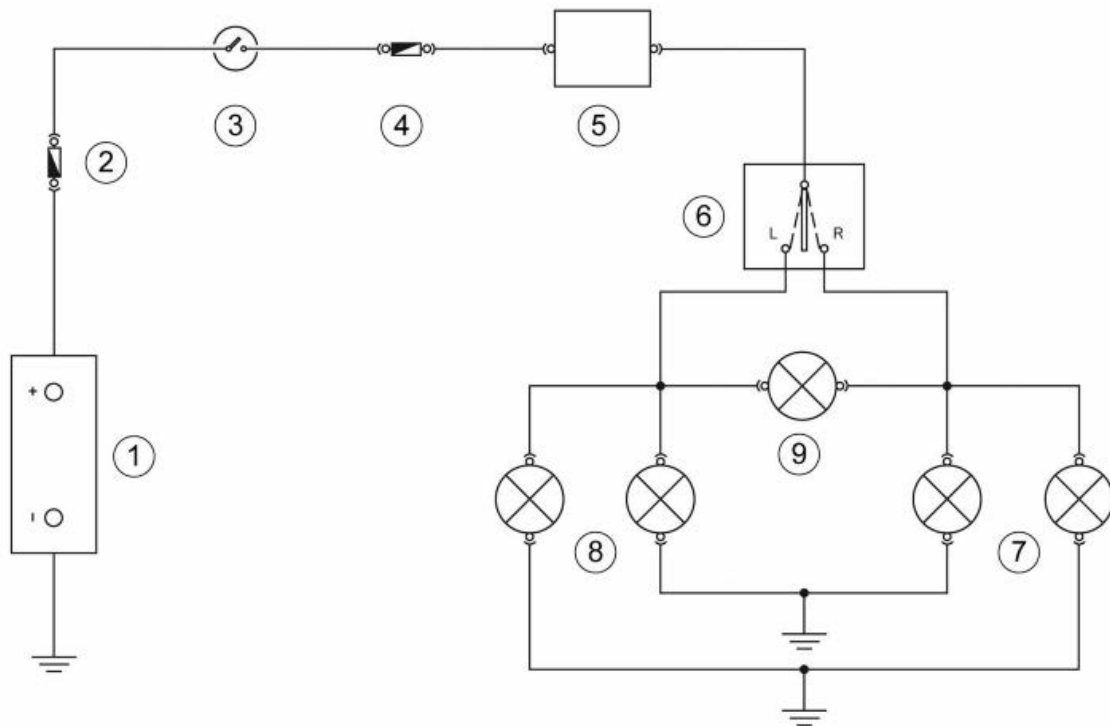
**KEY**

1. Battery
2. Fuse No. 01
3. Ignition switch contacts
4. Fuse No. 05
5. Turn indicator control device
6. Turn signal switch
7. Right turn indicator bulbs
8. Left turn indicator bulbs
9. Turn indicator warning light bulb

**WARNING**

**ALL CONTINUITY TESTS MUST BE CARRIED OUT WITH THE CORRESPONDING CONNECTORS DISCONNECTED.**

- 1) Check that bulbs operate properly.
- 2) Check fuses No. 01 and No. 05.
- 3) Check ignition switch contacts.
- 4) With the ignition switch set to «ON», check if there is voltage between the Blue-Black cable of the turn indicator switch and the ground connection. If there is not, check the wiring harnesses and the connections of the turn indicator control device.
- 5) Check the turn indicator switch contacts.

- 6) With the turn indicator switch pressed to the right, check if there is voltage between the White-Blue cable of the switch and the ground connection. If there is not, check the wiring harnesses.
- 7) With the turn indicator switch pressed to the left, check if there is voltage between the Pink cable of the switch and the ground connection. If there is not, check the wiring harnesses.
- 8) Check that the wiring harnesses of the bulbs and their ground connection are not interrupted.

## level indicators

### WARNING

**ALL CONTINUITY TESTS MUST BE CARRIED OUT WITH THE CORRESPONDING CONNECTORS DISCONNECTED.**

If faults are detected:

- 1) With a multimeter, check resistance values between the White-Green cable and the Black cable of the fuel level transmitter under different conditions.
- 2) If the transmitter operates correctly but the indication on the instrument panel is not exact, check that the wiring harnesses between them are not interrupted.

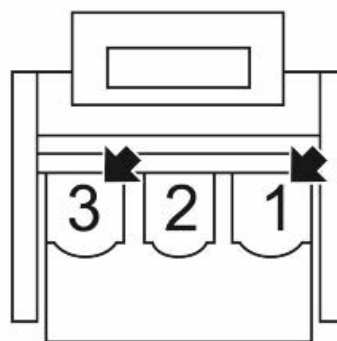

### Electric Characteristics

#### Resistance value with full tank

$\leq 7 \Omega$

#### Resistance value with empty tank

$90 + 13/-3 \Omega$

## Lights list

### For 125 E3 Vietnam MY2019 version

This section lists the bulb types required for the vehicle's equipment.



**BULBS**

	Specification	Desc./Quantity
1	High beam / low beam bulb	Type: Halogen (HS1) Power: 12V - 35/35W Quantity: 1
2	Front indicator light bulb	Type: Amber spherical Power: 12V - 10W Quantity: 1 RH + 1 LH
3	Rear indicator light bulb	Type: Spherical Power: 12V - 10W Quantity: 1 RH + 1 LH
4	Rear tail light bulb	Type: All glass Power: 12V - 5W Quantity: 2
5	Stop light bulb	Type: Spherical Power: 12V - 10W Quantity: 1
6	Licence plate light bulb	Type: All glass Power: 12V - 5W Quantity: 1

**Fuses**

**MAIN FUSE**

The electrical system is protected by a 20A main fuse «1» located near the battery. To reach it, the battery compartment cover must be removed as indicated in the «Battery» section.

In the same position are also two 10A «7» and 25A «8» fuses for the protection of the ABS control unit.

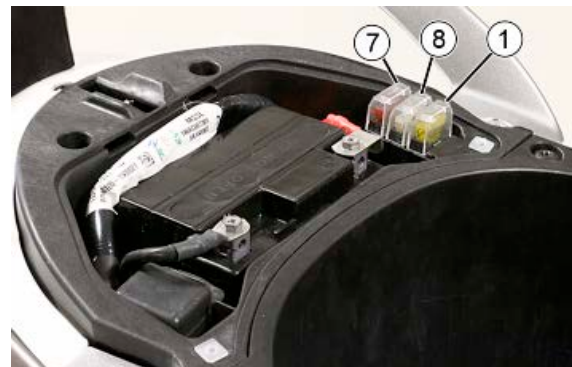

**MAIN FUSES TABLE**

	Specification	Desc./Quantity
1	Fuse 1	Threshold of operation: 20A Protected circuits: recharge circuit, general vehicle.
2	Fuse 7	Threshold of operation: 10A Protected circuits: battery-powered: ABS ECU.
3	Fuse 8	Threshold of operation: 25A Protected circuits: battery-powered: ABS ECU.

**SECONDARY FUSES**

The five secondary fuses are located under the front grille.



**SECONDARY FUSES TABLE**

	Specification	Desc./Quantity
1	Fuse 2	<b>Threshold of operation:</b> 7.5 A <b>Protected circuits:</b> battery-powered: engine control unit.
2	Fuse 3	<b>Threshold of operation:</b> 7.5 A <b>Protected circuits:</b> battery-powered: accessories preparation, instrument panel, saddle opening actuator.
3	Fuse 4	<b>Threshold of operation:</b> 5A <b>Protected circuits:</b> key powered: anti-tipping sensor, engine control unit.
4	Fuse 5	<b>Threshold of operation:</b> 5A <b>Protected circuits:</b> key powered: accessories preparation, turn indicator flasher, stop light, horn, starter relay coil, ABS control unit.
5	Fuse 6	<b>Threshold of operation:</b> 7.5 A <b>Protected circuits:</b> key powered: High beam/low beam lights, front and rear daylight running lights, licence plate light.

To access the auxiliary fuses proceed as follows:  
Remove the Piaggio clip-on badge using a flat screwdriver.



Unscrew the screw fixing the grille to the frame.



Remove the grille by slightly pulling it upwards and releasing the seat tongues.

**CAUTION**



**ELIMINATE THE CAUSE OF THE FAULT BEFORE REPLACING THE FUSE.  
WE STRONGLY RECOMMEND THAT YOU CONTACT AN AUTHORISED SERVICE CENTRE.**

**CAUTION**



**IN ORDER TO AVOID DAMAGING THE ELECTRICAL SYSTEM, NEVER DISCONNECT THE WIRING WHILE THE ENGINE IS RUNNING. DO NOT TIP THE VEHICLE TOO MUCH**



IN ORDER TO AVOID DANGEROUS LEAKAGE OF THE BATTERY ELECTROLYTE.

**CAUTION**



MODIFICATIONS OR REPAIRS TO THE ELECTRICAL SYSTEM, PERFORMED INCORRECTLY OR WITHOUT STRICT ATTENTION TO THE TECHNICAL SPECIFICATIONS OF THE SYSTEM CAN CAUSE MALFUNCTIONING AND RISK OF FIRE.

**CAUTION**



PROCEED WITH CAUTION. DO NOT DAMAGE THE TABS AND/OR THEIR CORRESPONDING SLOTS. HANDLE THE PLASTIC AND PAINTED COMPONENTS WITH CARE, DO NOT SCRATCH OR IMPAIR THEM.

**FOR 125 NO ABS MY2019 - VIETNAM/CHINA VERSION**

**MAIN FUSE**

The electrical system is protected by a main fuse «1» located near the battery. To reach it, the battery compartment cover must be removed as indicated in the «Battery» section.



**MAIN FUSE TABLE**

	Specification	Desc./Quantity
1	Fuse 1	<b>Threshold of operation:</b> 20A <b>Protected circuits:</b> recharge circuit, general vehicle.

**SECONDARY FUSES**

The five secondary fuses are located under the front grille.



**SECONDARY FUSES TABLE**

	Specification	Desc./Quantity
1	Fuse 2	<b>Threshold of operation:</b> 7.5 A <b>Protected circuits:</b> battery powered engine control unit.
2	Fuse 3	<b>Threshold of operation:</b> 7.5 A <b>Protected circuits:</b> battery power supply for instrument panel. <b>Ignition switched live:</b> Saddle opening actuator.
3	Fuse 4	<b>Threshold of operation:</b> 5A

	Specification	Desc./Quantity
		<b>Protected circuits:</b> ignition switched live engine control unit .
4	Fuse 5	<b>Threshold of operation:</b> 5A <b>Protected circuits:</b> ignition switched live to turn indicators control device, stop light, starter relay coil, USB socket.
5	Fuse 6	<b>Threshold of operation:</b> 7.5 A <b>Protected circuits:</b> ignition switched live instrument panel, high beam/low beam lights, rear daylight running lights, licence plate light.

To access the auxiliary fuses proceed as follows:  
Remove the Piaggio clip-on badge using a flat screwdriver.



Unscrew the screw fixing the grille to the frame.



Remove the grille by slightly pulling it upwards and releasing the seat tongues.

**CAUTION**



ELIMINATE THE CAUSE OF THE FAULT BEFORE REPLACING THE FUSE.  
WE STRONGLY RECOMMEND THAT YOU CONTACT AN AUTHORISED SERVICE CENTRE.

**CAUTION**



IN ORDER TO AVOID DAMAGING THE ELECTRICAL SYSTEM, NEVER DISCONNECT THE WIRING WHILE THE ENGINE IS RUNNING. DO NOT TIP THE VEHICLE TOO MUCH IN ORDER TO AVOID DANGEROUS LEAKAGE OF THE BATTERY ELECTROLYTE.

**CAUTION**



MODIFICATIONS OR REPAIRS TO THE ELECTRICAL SYSTEM, PERFORMED INCORRECTLY OR WITHOUT STRICT ATTENTION TO THE TECHNICAL SPECIFICATIONS OF



---

THE SYSTEM CAN CAUSE MALFUNCTIONING AND RISK OF FIRE.

CAUTION



PROCEED WITH CAUTION.  
DO NOT DAMAGE THE TABS AND/OR THEIR CORRESPONDING SLOTS. HANDLE THE PLASTIC AND PAINTED COMPONENTS WITH CARE, DO NOT SCRATCH OR IMPAIR THEM.

---

## Sealed battery

If the vehicle is provided with a sealed battery, the only maintenance required is the check of its charge and recharging, if necessary.

These operations should be carried out before delivering the vehicle, and on a six-month basis while the vehicle is stored in open circuit.

Besides upon pre-delivery it is therefore necessary to check the battery charge and recharge it, if required, before storing the vehicle and afterwards every six months.

### INSTRUCTIONS FOR BATTERY REFRESH AFTER OPEN CIRCUIT STORAGE

#### 1) Voltage check

Before installing the battery on the vehicle, check the open circuit voltage with a standard tester.

- If voltage exceeds 12.60 V, the battery can be installed without any renewal recharge.
- If voltage is below 12.60 V, a renewal recharge is required as explained in 2).

#### 2) Constant voltage battery charge mode

- Constant voltage charge equal to 14.40 - 14.70V
- Initial charge voltage equal to 0.3 - 0.5 for Nominal capacity
- Charge time:  
10 - 12 h recommended

Minimum 6 h

Maximum 24 h

#### 3) Constant current battery charge mode

- Charge current equal to 1/10 of the battery rated capacity
  - Charge time: Maximum 5 h
- 

## Battery installation

VRLA battery (valve-regulated lead-acid battery) Maintenance Free (MF)

WARNING

BATTERY ELECTROLYTE IS TOXIC AND IT MAY CAUSE SERIOUS BURNS. IT CONTAINS SULPHURIC ACID. AVOID CONTACT WITH EYES, SKIN AND CLOTHING. IF IT ACCIDENTALLY COMES INTO CONTACT WITH YOUR EYES OR SKIN, WASH WITH ABUNDANT WATER FOR APPROX. 15 MIN. AND SEEK IMMEDIATE MEDICAL ATTENTION. IN THE EVENT OF ACCIDENTAL INGESTION OF THE LIQUID, IMMEDIATELY DRINK LARGE QUANTITIES OF WATER OR MILK. MAGNESIUM MILK, BATTERED EGG OR VEGETABLE OIL. SEEK IMMEDIATE MEDICAL ATTENTION.

---

**BATTERIES PRODUCE EXPLOSIVE GAS; KEEP CLEAR OF NAKED FLAMES, SPARKS OR CIGARETTES; VENTILATE THE AREA WHEN RECHARGING INDOORS. ALWAYS WEAR EYE PROTECTION WHEN WORKING IN THE PROXIMITY OF BATTERIES. KEEP OUT OF THE REACH OF CHILDREN.**

### 1) Battery preparation

Position the battery on a flat surface. Remove the adhesive sheet closing cells and proceed as quickly as possible to run the subsequent activation phases.

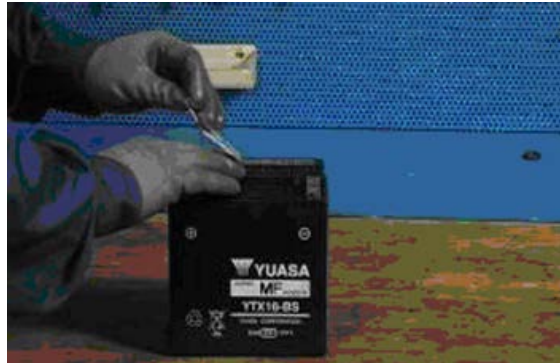

### 2) Electrolyte preparation.

Remove the container of the electrolyte from the pack. Remove and preserve cover strips from the container, in fact, the strip will later be used as a closing cover.

**Note:** Do not pierce the sealing of the container or the container itself because inside there is sulphuric acid.



### 3) Procedure for filling the battery with acid.

Position the electrolyte container upside down with the six areas sealed in line with the six battery filler holes. Push the container down with enough force to break the seals. The electrolyte should start to flow inside the battery.

**Note:** Do not tilt the container to prevent the flow of electrolyte from pausing or stopping.



### 4) Control the flow of electrolyte

Make sure air bubbles are rising from all six filling holes. Leave the container in this position for 20 minutes or more.

**Note:** If there are no air bubbles coming out of the filling holes, lightly tap the bottom of the container two or three times. Do not remove the container from the battery.

### 5) Take out the container.

Make sure all the electrolyte in the battery is drained. Gently tap the bottom of the container if electrolyte remains in the container. Only once the container is completely empty, gently remove the container itself from the battery. Leave the battery to rest, without sealing the six cells, for at least 1 hour before charging.

**6) Recharging the new battery**

With the above-mentioned procedure, the battery will have gained around 70% - 75% of its total electrical capacity. Before installing the battery on the vehicle, it must be fully charged and then must be recharged.

**If the battery is to be installed on the vehicle prior to this pre-charged one, the battery will not be able to exceed 75% charge without jeopardising its useful life on vehicle.**

The dry charge battery MF like the completely loaded YTX, must have a zero load voltage between 12.8 - 13.15 V Bring the battery to full charge, using the 020648Y battery charger:

- a - select the type of battery with the red switch on the left of the panel battery charger panel
- b - select NEW on the yellow timer
- c - connect the clamps of the battery charger to the battery poles (black clamp to negative pole (-) and red clamp to positive pole (+)).



- d - Press the red button, as shown in figure.



- e - Press the "MF" black button to activate the battery recharge **Maintenance Free** as shown in figure.



f - Check the ignition of the green LED indicated with a red arrow in figure.



g - The activation cycle of the new battery lasts for 30 minutes after the ignition of the recharge LED has taken place



h - Disconnect the clamps from the battery and check the voltage, if voltages are detected of less than 12.8 V, proceed with a new recharge of the battery starting from point c of the recharge procedure of **the new battery**, otherwise go to point i



i - The battery is now properly activated, disconnect the battery charger from the power supply and unplug the terminals from the battery.

### 7) Battery closing.

Insert the airtight cover strips into the filling holes.

Press horizontally with both hands and make sure that the strip is levelled with the top part of the battery.

**Note:** To do this, do not use sharp objects that could damage the closing strip, use gloves to protect your hands and do not bring your face close to the battery.

The filling process is now complete.

Do not remove the strip of caps under any circumstances, do not add water or electrolyte.

Assembly procedure of the battery on the vehicle.

## Connectors

The connectors are represented as on the cable input side

**ENGINE IDLE VALVE**

1. BiNe - CDI
2. NeVe - Injection loads

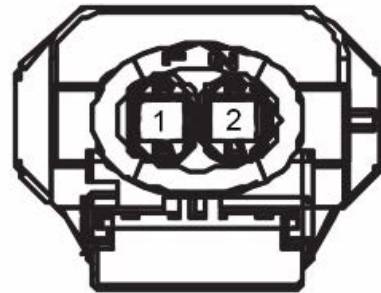

**REAR LIGHT ASSEMBLY**

1. BiNe - Stop light
2. Ne - Ground
3. Ro - Left turn indicator
4. BiBL - Right turn indicator
5. GiNe - Daytime running light

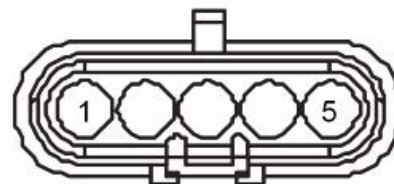

**SADDLE OPENING ACTUATOR**

1. BLNe - Saddle opening switch
2. BL - Ground

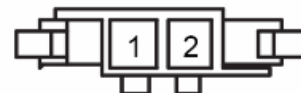

**CDI**

1. Ve - fuel pump
2. MaBi - injection warning light
3. AzRs - lambda heater
4. Gi - Immobilizer LED
5. RsBi - + Batt
6. RsGi - injector
7. GrVe - Sensor ground
8. RoNe - H.V. coil
9. NeVe - Injection loads
10. ArNe - K Line
11. VeBi - Start enable

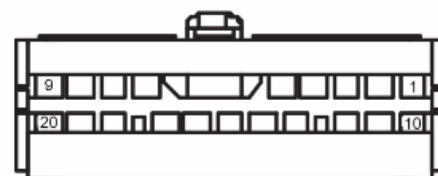

12. Rs - Pick-up
13. VeBL - Lambda probe
14. ArBi - Throttle position sensor
15. Ar - Tip over sensor
16. AzVe - Engine temperature sensor
17. BiNe - Engine idle adjustment valve
18. RsNE - Sensor power supply
19. Ne - Ground
20. ArVe - Key powered

---

**TURN INDICATOR SWITCH**

- A. Ro - Left turn lights
- B. BiBI - Right turn indicators
- C. BLNe - Turn indicator device

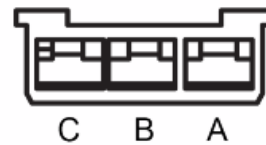

---

**STOP BUTTONS**

1. Bi - Fuel system
2. BiNe - Stop light

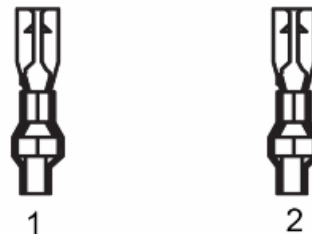

---

**START-UP RELAY**

- A. Rs - Battery positive
- B. Rs - Starter motor
- C. VeBi - CDI
- D. Vi - Starter button



---

**THROTTLE POSITION SENSOR**

- A. GrVe - Sensor ground
- B. RsNe - CDI
- C. ArBi - CDI

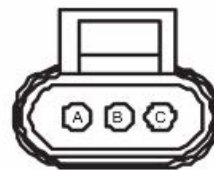

---

**LIGHT SWITCH**

- A. Vi - High beam light
- B. GiNe - Supply
- C. Ma - Low beam lights
- D. GiNe - Supply



---

**ROLLOVER SENSOR**

- 1. NC
- 2. GrVe - Ground
- 3. ArVe - Supply
- 4. ArNe - CDI



---

**SADDLE OPENING SWITCH**

- 1. RsGr - Supply
- 2. BL - Saddle opening actuator

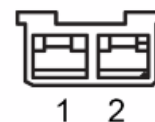

---

**MODE BUTTON**

1. Gr - Instrument panel
2. Ne - Ground

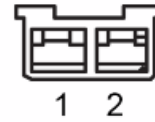

---

**COIL**

1. RoNe - CDI
2. Ne - Ground

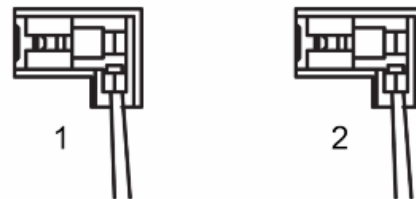

---

**VOLTAGE REGULATOR**

1. RsNe - Supply
2. NC
3. Ne - Ground
4. Gi - Flywheel
5. Gi - Flywheel
6. Gi - Flywheel

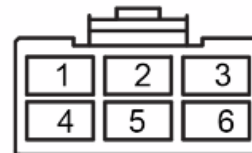

---

**STARTER BUTTON**

1. BiNe - Stop buttons
2. Vi - Starter relay

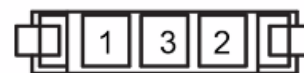

**LAMBDA PROBE**

1. VeBL - CDI
2. GrVe - Ground
3. AzRs - CDI
4. NeVe - Injection loads

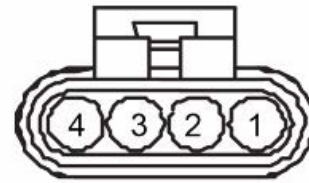

**TURN INDICATOR DEVICE**

1. BLNe - Turn indicator switch
2. Bi - Fuel system

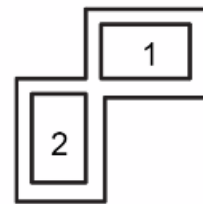

**IGNITION SWITCH**

1. Ne - Ground
2. NC
3. BLNe - Saddle opening actuator supply
4. ArRS - Key powered
5. RsNe - Battery supply

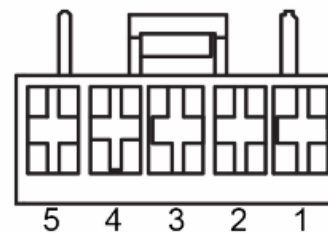

**HEADLIGHT**

1. Vi - High beam light
2. Ma - Low beam light
3. Ne - Ground

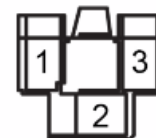

**ABS SENSOR**

1. AzNe - Ground
2. AzRs - Signal



**FUEL GAUGE**

1. Ve - Signal
2. Ne - Ground
3. NC



**FRONT RIGHT TURN INDICATOR**

1. BiBL - Turn indicator switch
2. Ne - Ground



**FRONT LEFT TURN INDICATOR**

1. Ro - Turn indicator switch
2. Ne - Ground



**RIGHT FRONT DAYLIGHT RUNNING LIGHT**

- 1. Ne - Ground
- 2. GiNe - Supply

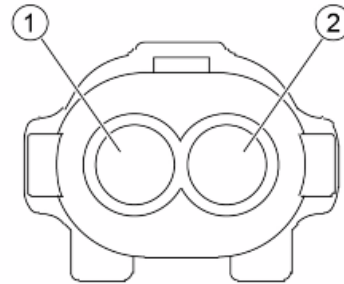

**LEFT FRONT DAYTIME RUNNING LIGHTS**

- 1. Ne - Ground
- 2. GiNe - Supply

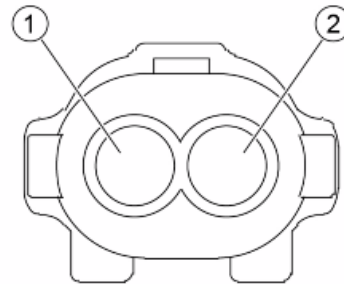

**INSTRUMENT PANEL**

- 1. RoBi - Oil pressure warning light
- 2. Gr - MODE button
- 3. Ro - Left turn lights indicator
- 4. BiBl - Right turn light indicator
- 5. Vi - High beam warning light
- 6. Ar - ABS warning light
- 7. NC
- 8. NC
- 9. NC
- 10. NC
- 11. NC
- 12. BiVe - Fuel level sensor
- 13. NC
- 14. Az - Speed sensor
- 15. NC
- 16. MaBi - injection warning light
- 17. Ne - Ground
- 18. Gi - Immobilizer warning light
- 19. GiNe - Key powered
- 20. RsGr - Battery supply

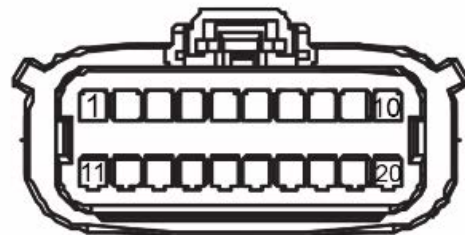

**ABS CONTROL UNIT**

1. Ne - Ground
2. NC
3. AzNe - Ground sensor
4. Bi - Fuel system
5. ArNe - K Line
6. NC
7. NC
8. Az - Speedometer
9. RsBi - Battery supply
10. Ne - Ground
11. NC
12. AzRs - Sensor signal
13. NC
14. NC
15. NC
16. NC
17. Ar - ABS warning light
18. RsGi - Fuel system

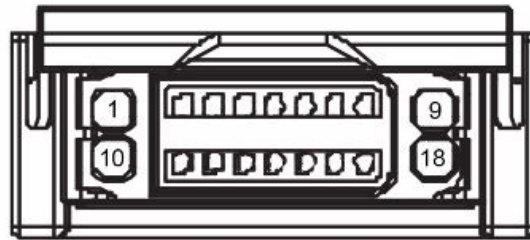
**FLYWHEEL**

- 1A. Gi - Flywheel
- 1B. GrVe - Ground
- 1C. Gi - Flywheel
- 2A. RoBi - Oil pressure sensor
- 2B. Gi - Flywheel
- 2C. Rs - System supply

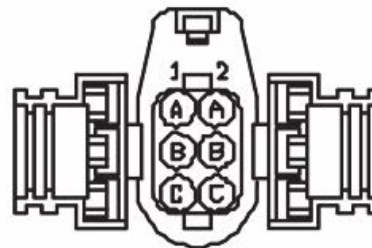
**FUEL PUMP**

1. Ve - CDI
2. NeVe - Injection loads



**HORN**

- 1. GrNe - Horn button
- 2. Ne - Ground

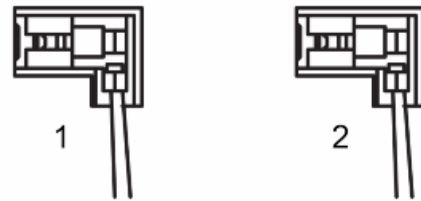

**INJECTOR**

- 1. RsGi - CDI
- 2. - Injection loads



**ENGINE TEMPERATURE SENSOR**

- 1. AzVe - CDI
- 2. GrVe - Ground



**LICENCE PLATE LIGHT**

- 1. GiNe - Supply
- 2. Ne - Ground

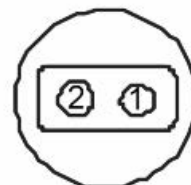

---

**USB PORT**

1. Bi - Fuel system
2. Ne - Ground

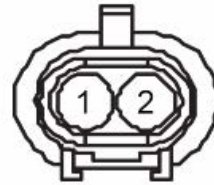

---

**ACCESSORIES PRE-INSTALLATION**

1. Ne - Ground
2. BiVe - Fuel level sensor
3. NC
4. NC
5. ArNe - K Line
6. NC
7. RsGr - Battery supply
8. Bi - Key powered
9. BLNe - Saddle opening actuator ground
10. BL - Saddle opening actuator supply
11. Ro - Left turn lights
12. BiBI - Right turn indicators
13. Vi - High beam lights
14. Az - Speedometer



---

**DIAGNOSTIC SOCKET**

1. NC
2. Ne - Ground
3. ArNe - K Line



**DIAGNOSTICS SOCKET (China version)**

1-3 -

4 Ground (AzVe)

5-6 -

7 Diagnostics (AzBi)

8-15 -

16 Fuse power supply (R)

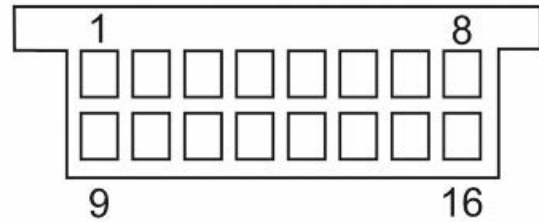

**HORN BUTTON**

1. Bi - Fuel system

2. GrNe - Horn



**FOR 125 NO ABS MY2019 - VIETNAM/CHINA VERSION**

**ENGINE IDLE VALVE**

1. BiNe - CDI

2. NeVe - Injection loads

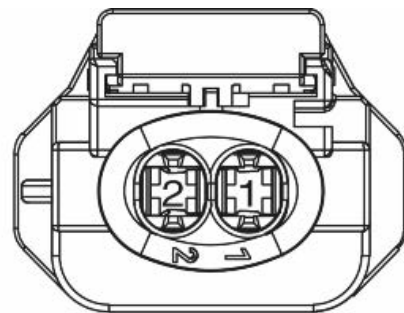

**REAR LIGHT ASSEMBLY**

1. BiNe - Stop light

2. Ne - Ground

3. Ro - Left turn indicator

4. BiBL - Right turn indicator

5. GiNe - Daytime running light

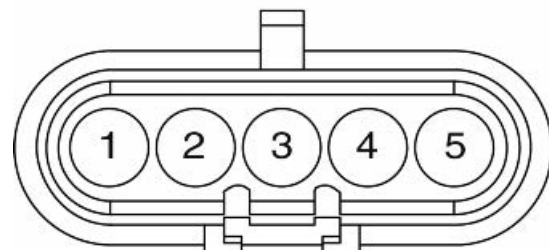

**SADDLE OPENING ACTUATOR**

1. BLNe - Signal input (-) from ignition switch
2. BL - Signal input (+) from saddle opening button

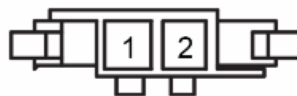
**CDI**

1. Ve - fuel pump
2. MaBi - injection warning light
3. AzRs - lambda heater
4. Gi - Immobilizer LED
5. RsBi - + Batt
6. RsGi - injector
7. GrVe - Sensor ground
8. RoNe - H.V. coil
9. NeVe - Injection loads
10. ArNe - K Line
11. VeBi - Start enable
12. Rs - Pick-up
13. VeBL - Lambda probe
14. ArBi - Throttle position sensor
15. Ar - Stand button
16. AzVe - Engine temperature sensor
17. BiNe - Engine idle adjustment valve
18. RsNE - Sensor power supply
19. Ne - Ground
20. ArVe - Key powered

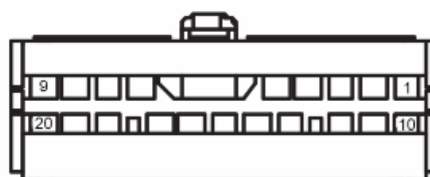
**TURN INDICATOR SWITCH**

- A. Ro - Left turn lights
- B. BiBI - Right turn indicators
- C. BLNe - Turn indicator device

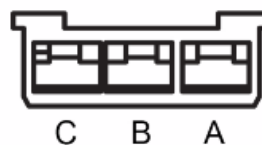

**STOP BUTTONS**

- 1. Bi - Fuel system
- 2. BiNe - Stop light

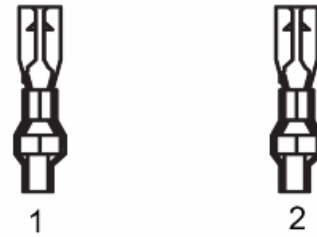

**START-UP RELAY**

- A. Rs - Battery positive
- B. Rs - Starter motor
- C. VeBi - CDI
- D. Vi - Starter button



**THROTTLE POSITION SENSOR**

- A. GrVe - Ground reference injection control unit
- B. RsNe - Injection control unit power
- C. ArBi - Signal for injection control unit

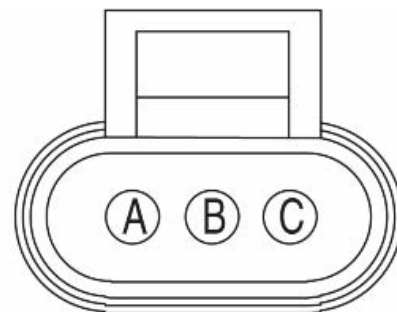

**LIGHT SWITCH**

- A. Vi - High beam light
- B. GiGr - Light switch
- C. Ma - Low beam lights
- D. GiBi - Ignition key-controlled power supply

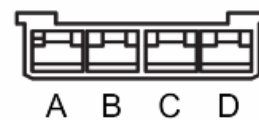

---

**SADDLE OPENING SWITCH**

1. RsGr - Supply
2. BL - Saddle opening actuator

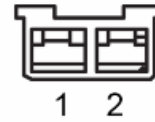

---

**MODE BUTTON**

1. Gr - Instrument panel
2. Ne - Ground

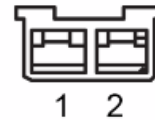

---

**COIL**

1. RoNe - CDI
2. Ne - Ground

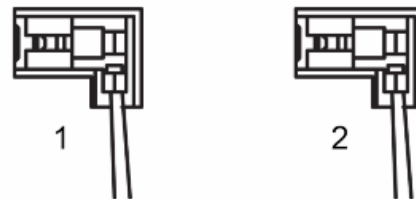

---

**VOLTAGE REGULATOR**

1. RsNe - Supply
2. NC
3. Ne - Ground
4. Gi - Flywheel
5. Gi - Flywheel
6. Gi - Flywheel

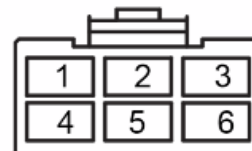

**STARTER BUTTON**

- 1. BiNe - Stop buttons
- 2. Vi - Starter relay



**LAMBDA PROBE**

- 1. VeBL - CDI
- 2. GrVe - Ground
- 3. AzRs - CDI
- 4. NeVe - Injection loads

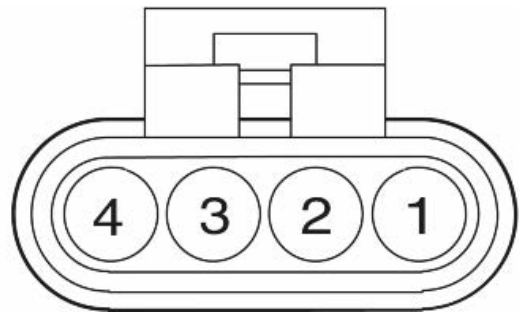

**TURN INDICATOR DEVICE**

- L. BLNe - Turn indicator switch
- B. Bi - Fuel system

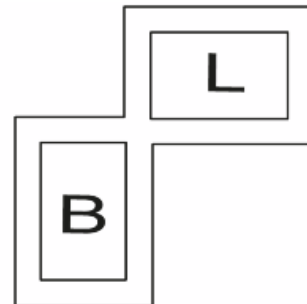

**IGNITION SWITCH**

- 1. BLNe - Saddle opening actuator power supply
- 2. NC
- 3. Ne - Ground
- 4. RsNe - Battery supply
- 5. ArRs - Ignition key-controlled power supply

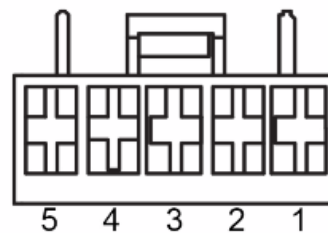

**HEADLIGHT**

1. Vi - High beam light
2. Ma - Low beam light
3. Ne - Ground

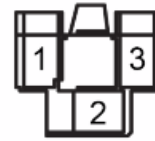
**FUEL GAUGE**

1. BiVe - Fuel reserve warning light
2. Ne - Ground
3. NC

**FRONT RIGHT TURN INDICATOR**

1. BiBL - Turn indicator switch
2. Ne - Ground

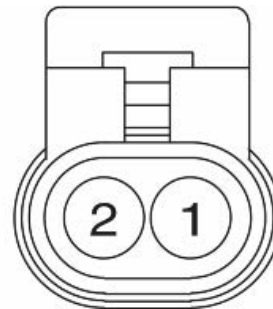
**FRONT LEFT TURN INDICATOR**

1. Ro - Turn indicator switch
2. Ne - Ground

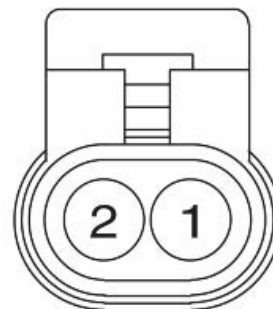
**INSTRUMENT PANEL**

1. RoBi - Oil pressure warning light
2. Gr - MODE button
3. Ro - Left turn lights indicator
4. BiBl - Right turn light indicator
5. Vi - High beam warning light
6. NC

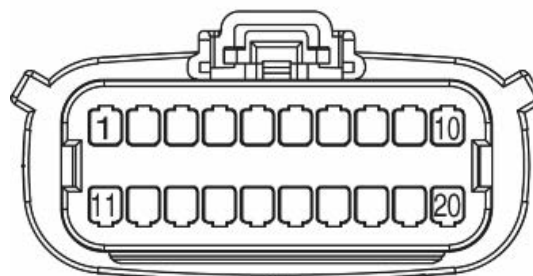

- 7. NC
- 8. NeVe - Speed sensor
- 9. NC
- 10. NC
- 11. NC
- 12. BiVe - Fuel level sensor
- 13. NC
- 14. Az - Speed sensor
- 15. NC
- 16. MaBi - injection warning light
- 17. Ne - Ground
- 18. Gi - Immobilizer warning light
- 19. GiNe - Key powered
- 20. RsGr - Battery supply

**FLYWHEEL**

- 1A. Gi - Flywheel
- 1B. GrVe - Ground
- 1C. Gi - Flywheel
- 2A. RoBi - Oil pressure sensor
- 2B. Gi - Flywheel
- 2C. Rs - System supply

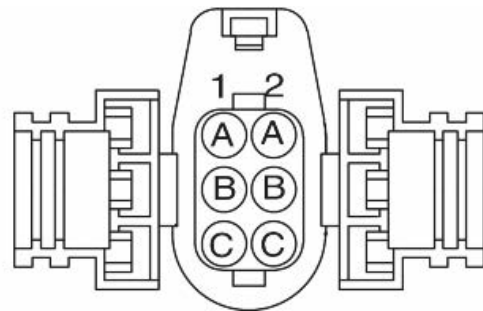

**FUEL PUMP**

- 1. Ve - CDI
- 2. NeVe - Injection loads

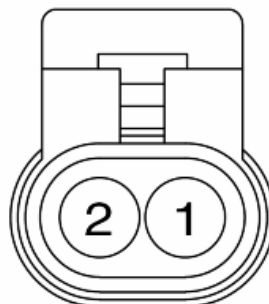

**HORN**

1. GrNe - Horn button
2. Ne - Ground

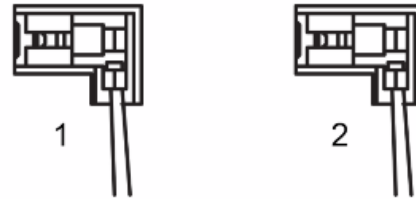
**INJECTOR**

1. RsGi - Signal (-) input from injection control unit
2. NeVe - Injection control unit power

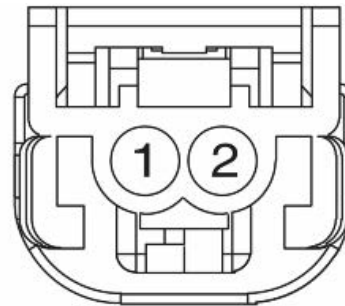
**ENGINE TEMPERATURE SENSOR**

1. AzVe - CDI
2. GrVe - Ground

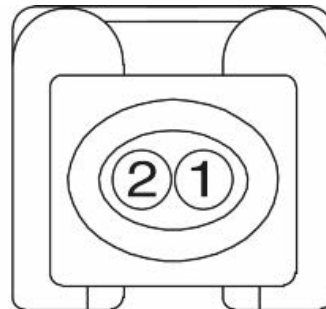
**LICENCE PLATE LIGHT**

1. GiNe - Supply
2. Ne - Ground

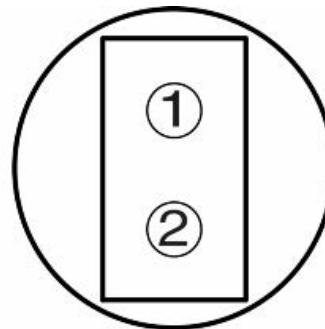
**USB PORT**

1. Bi - Fuel system
2. Ne - Ground

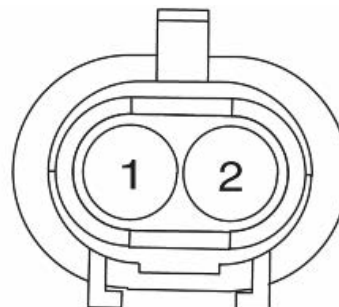

**DIAGNOSTIC SOCKET**

- 1. NC
- 2. Ne - Ground
- 3. ArNe - K Line

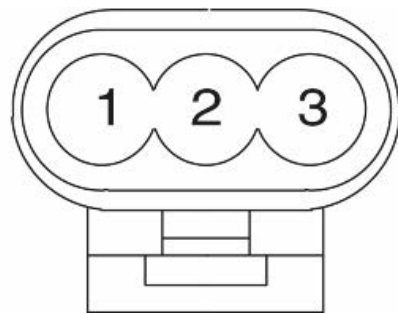

**DIAGNOSTICS SOCKET (China version)**

- 1-3 -
- 4 Ground (AzVe)
- 5-6 -
- 7 Diagnostics (AzBi)
- 8-15 -
- 16 Fuse power supply (R)

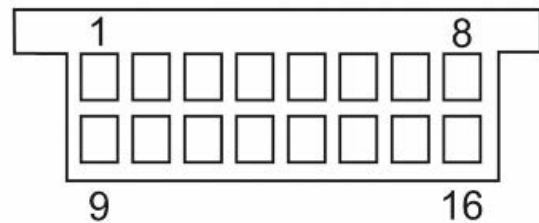

**HORN BUTTON**

- 1. Bi - Fuel system
- 2. GrNe - Horn
- 3. NC

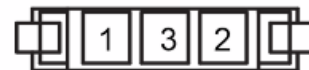

**LIGHT SWITCH**

- A. GiGr - Headlamp signal output
- B. GiNe - City light signal output
- C. GiBi - Ignition key-controlled power supply input

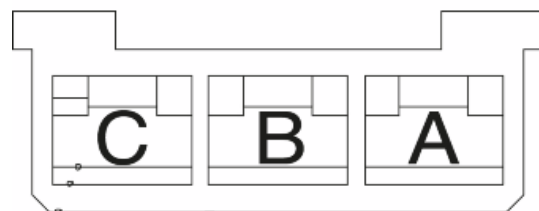

**SPEED SENSOR**

- 1. Az - Signal
- 2. NeVe - Negative from instrument panel
- 3. Ne - Ground

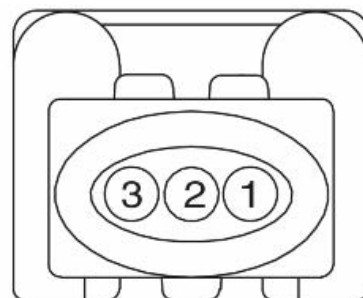

**FUSE F06**

1. ArRs - Ignition key-controlled power supply input
2. GiBi - Ignition key-controlled power supply output
3. Not connected
4. Not connected

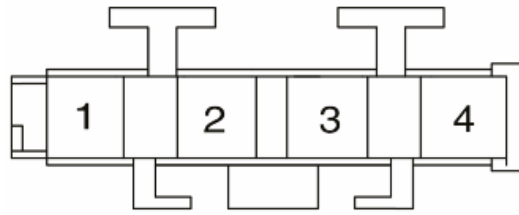
**FUSES F04 - F05**

1. ArRs - Ignition key-controlled power supply input
2. ArVe - Ignition key-controlled power supply output
3. ArRs - Ignition key-controlled power supply input
4. Bi - Ignition key-controlled power supply output

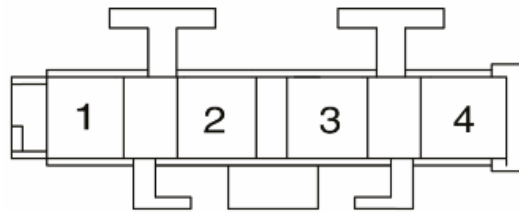
**FUSES F02 - F03**

1. RsNe - Battery power input
2. RsBi - Battery supply output
3. RsNe - Battery power input
4. RsGr - Battery supply output

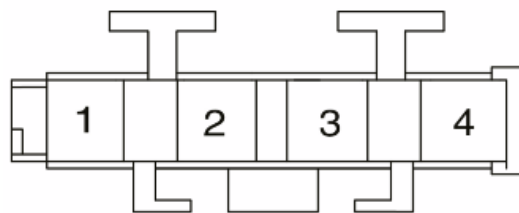
**STAND BUTTON**

1. GrVe - Ground reference
2. Ar - Control unit signal output

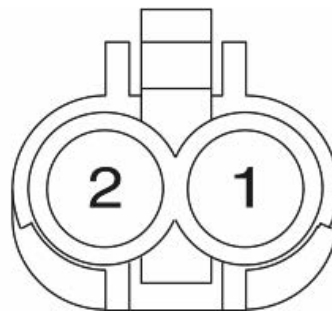
**FRAME GROUND**

1. Ne - Ground



**CHASSIS-ENGINE GROUND**

- 1. Ne - Ground



**BATTERY NEGATIVE**

- 1. Ne - Ground



**BATTERY POSITIVE**

- 1. Rs - Battery power supply

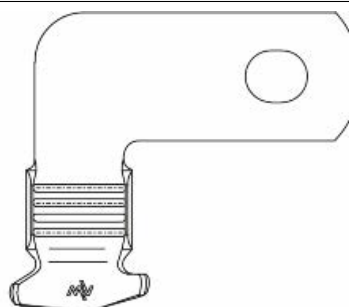

**FUSE F01**

- 1. Rs - Battery power supply input
- 2. RsNe - Battery power supply output

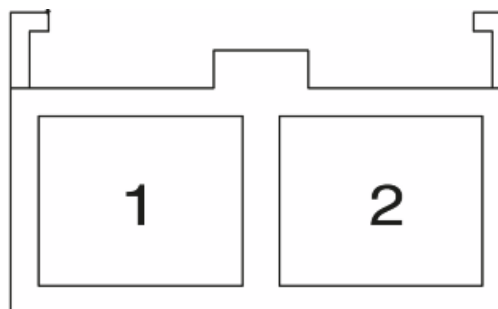

**STARTER MOTOR POSITIVE**

- 1. RS - Starter relay contact power supply input

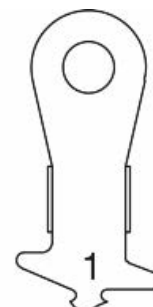

**Diagnostic instrument**

N.B.

**AT EACH SCHEDULED SERVICE, USE THE DIAGNOSTIC TOOL TO CHECK FOR ERRORS AND CHECK THAT ALL PARAMETERS ARE CORRECT. ENSURE THAT THE VEHICLE CALIBRATION IS UP TO DATE AFTER UPDATING THE DIAGNOSTIC TOOL.**

**CAUTION**

**AFTER THE PROVIDED MAINTENANCE PROGRAM IS INDICATED TO PROCEED WITH THE MAINTENANCE OF THE VEHICLE STARTING FROM THE SERVICE OF 5,000 Km (3,106 mi) OR 5 MONTHS.**

**IMMOBILIZER ANTENNA****Function**

Detects the transponder code in the key and sends it to the engine control unit.

**ERRORS**

**Immobilizer P0513** - unknown transponder.

Error cause

The key has the working transponder, but it is not within the recognised ones.

Troubleshooting

Store the new key.

**Immobilizer P1514** - not working antenna or key without transponder.

Error cause

Antenna electrical fault or the key has no transponder or the transponder is damaged.

Troubleshooting

Replace the key and store it if necessary. If the error persists, check the electrical characteristics and the continuity of the antenna circuit:

- Disconnect the antenna connector and check the correct resistance value at the ends.
- Check wiring continuity between the antenna and the engine control unit and restore if necessary.

**Electric Characteristics****Resistance at 20°C**

7.66 ± 5% Ω

---

**BATTERY****ELECTRICAL ERRORS****Low power supply P0562**Error cause

The battery voltage is below the minimum threshold.

Troubleshooting

Check the battery, the voltage regulator, the correct function of the alternator (flywheel) and the relative connectors.

**High power supply P0563**Error cause

The battery voltage is over the maximum threshold.

Troubleshooting

---

Check the battery, the voltage regulator, the correct function of the alternator (flywheel) and the relative connectors.

**HV COIL**

**Function**

Allows generation of the electrical discharge on the spark plug, with an increase of voltage.

**Pin-out:**

- 1. Control unit power
- 2. Ground lead



**ELECTRICAL ERRORS**

**H.V. coil P0351** - open circuit.

Error cause

Open circuit: circuit interruption.

Troubleshooting

Open circuit:

- Carry out the check procedure of the coil and control unit connectors.
- Check the ground and battery-powered insulation of coil PIN 1.
- Verify continuity of the wiring harness between the coil and control unit: Coil PIN 1 - control unit PIN 8.
- 8. If there is no continuity, restore the wiring harness.
- Check the ground connection of coil PIN 2. Repair the wiring harness if necessary.
- If the above tests provided a positive result, the coil should be replaced.

**INJECTOR**

**Function**

Provide the correct amount of fuel at the correct time.

**Operation / Operating principle**

Injector coil is excited for the petrol passage to open.

**Pin-out:**

- 1. Positive from control unit
- 2. Negative from control unit (injector activation)

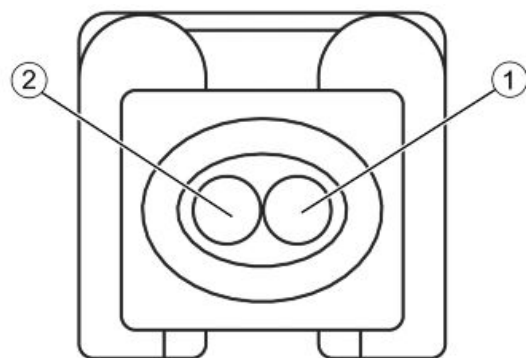

**ELECTRICAL ERRORS**

**Low injector voltage P0261** - open circuit or short-circuit to negative.

Error cause

Open circuit or short-circuit to negative: interruption of the circuit or null voltage at PIN 2 of the injector connector.

#### Troubleshooting

Open circuit:

- Perform the check of the injector and control unit connectors.
- Check the continuity of the wiring harness between the control unit connector and injector connector: Control unit PIN 6 - injector PIN 2 and control unit PIN 9 - injector PIN 1. If there is no continuity, restore the wiring harness.

Short-circuit to negative:

- Disconnect the control unit connector and the injector connector.
- Check the injector connector PIN 2 ground insulation (corresponding to control unit connector PIN 6). If there is no insulation, restore the wiring harness.

- With the injector connector disconnected and the control unit connector connected, turn ignition switch to ON and activate the component using the diagnostic tool.

- Check if there is intermittent voltage (4 ms every second for 5 seconds) at the ends of the injector connector.

- If there is no voltage, check the continuity of the wiring harness between control unit PIN 9 and injector PIN 1 and restore it if necessary.

- If the above tests provided a positive result, the injector should be replaced.

**High injector voltage P0262** - short-circuit to positive.

#### Error cause

Short-circuit to positive: excessive voltage to PIN 6 of the control unit connector.

#### Troubleshooting

Short-circuit to positive:

- Disconnect the control unit connector and the injector connector.
- Verify that there is no short to battery positive on injector connector PIN 2 (corresponding to control unit connector PIN 6); if there is a short circuit, restore the wiring harness.

- With the injector connector disconnected and the control unit connector connected, turn ignition switch to ON and activate the component using the diagnostic tool.

- Check if there is intermittent voltage (4 ms every second for 5 seconds) at the ends of the injector connector.

- If there is no voltage, check the continuity of the wiring harness between control unit PIN 9 and injector PIN 1 and restore it if necessary.

- If the above tests provided a positive result, the injector should be replaced.

---

**FOR 125 NO ABS MY2019 - VIETNAM/CHINA VERSION**

**INJECTOR****Function**

Provide the correct amount of fuel at the correct time.

**Operation / Operating principle**

Injector coil is excited for the petrol passage to open.

**Pin-out:**

1. Signal (-) input from injection control unit
2. Injection control unit power

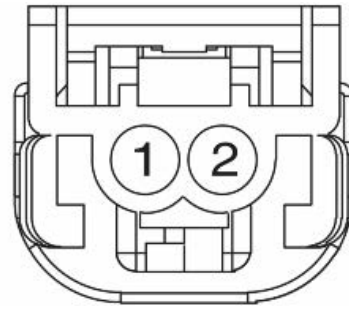
**ELECTRICAL ERRORS**

**Low injector voltage P0261** - open circuit or short-circuit to negative.

Error cause

Open circuit or short-circuit to negative: interruption of the circuit or null voltage at PIN 1 of the injector connector.

Troubleshooting

Open circuit:

- Perform the check of the injector and control unit connectors.
- Check the continuity of the wiring harness between the control unit connector and injector connector: Control unit PIN 6 - injector PIN 2 and control unit PIN 9 - injector PIN 1. If there is no continuity, restore the wiring harness.

Short-circuit to negative:

- Disconnect the control unit connector and the injector connector.
- Check the injector connector PIN 2 ground insulation (corresponding to control unit connector PIN 6). If there is no insulation, restore the wiring harness.
- With the injector connector disconnected and the control unit connector connected, turn ignition switch to ON and activate the component using the diagnostic tool.
- Check if there is intermittent voltage (4 ms every second for 5 seconds) at the ends of the injector connector.
- If there is no voltage, check the continuity of the wiring harness between control unit PIN 9 and injector PIN 1 and restore it if necessary.
- If the above tests provided a positive result, the injector should be replaced.

**High injector voltage P0262** - short-circuit to positive.

Error cause

Short-circuit to positive: excessive voltage to PIN 6 of the control unit connector.

Troubleshooting

Short-circuit to positive:

- Disconnect the control unit connector and the injector connector.

- Verify that there is no short to battery positive on injector connector PIN 2 (corresponding to control unit connector PIN 6); if there is a short circuit, restore the wiring harness.
- With the injector connector disconnected and the control unit connector connected, turn ignition switch to ON and activate the component using the diagnostic tool.
- Check if there is intermittent voltage (4 ms every second for 5 seconds) at the ends of the injector connector.
- If there is no voltage, check the continuity of the wiring harness between control unit PIN 9 and injector PIN 1 and restore it if necessary.
- If the above tests provided a positive result, the injector should be replaced.

---

## FUEL PUMP

### Function

Pump fuel from the tank to introduce it in the injection circuit.

### Pin-out:

1. Not connected
2. Negative from control unit (injector activation)
3. Not connected
4. Not connected
5. Positive from control unit



## ELECTRICAL ERRORS

**Low fuel pump voltage P0231** - open circuit or short-circuit to negative.

### Error cause

Open circuit or short-circuit to negative: interruption of the circuit or null voltage at PIN 2 of the pump connector.

### Troubleshooting

Open circuit:

- Perform the check of the fuel pump and control unit connectors.
- Check the continuity of the wiring harness between the control unit connector and pump connector: Control unit PIN 1 - pump PIN 2 and control unit PIN 9 - pump PIN 5. If there is no continuity, restore the wiring harness.

Short-circuit to negative:

- Disconnect the control unit connector and the pump connector.
- Check the pump connector PIN 2 ground insulation (corresponding to control unit connector PIN 1). If there is no insulation, restore the wiring harness.

**High fuel pump voltage P0232** - short-circuit to positive.

### Error cause

Short-circuit to positive: excessive voltage at PIN 1 of the control unit connector.

Troubleshooting

Short-circuit to positive:

- Disconnect the control unit connector and the pump connector.
  - Verify that there is no short to battery positive on pump connector PIN 2 (corresponding to control unit connector PIN 1); if there is a short circuit, restore the wiring harness.
- 

**FOR 125 NO ABS MY2019 - VIETNAM/CHINA VERSION****FUEL PUMP****Function**

Pump fuel from the tank to introduce it in the injection circuit.

**Pin-out:**

1. Signal (-) input from injection control unit
2. Control unit power

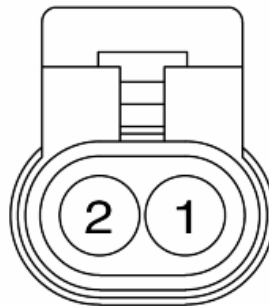
**ELECTRICAL ERRORS**

**Low fuel pump voltage P0231** - open circuit or short-circuit to negative.

Error cause

Open circuit or short-circuit to negative: interruption of the circuit or null voltage at PIN 1 of the pump connector.

Troubleshooting

Open circuit:

- Perform the check of the fuel pump and control unit connectors.
- Check the continuity of the wiring harness between the control unit connector and pump connector: Control unit PIN 1 - pump PIN 2 and control unit PIN 9 - pump PIN 1. If there is no continuity, restore the wiring harness.

Short-circuit to negative:

- Disconnect the control unit connector and the pump connector.
- Check the pump connector PIN 1 ground insulation (corresponding to control unit connector PIN 1). If there is no insulation, restore the wiring harness.

**High fuel pump voltage P0232** - short-circuit to positive.

Error cause

---

Short-circuit to positive: excessive voltage at PIN 1 of the control unit connector.

#### Troubleshooting

Short-circuit to positive:

- Disconnect the control unit connector and the pump connector.
- Verify that there is no short to battery positive on pump connector PIN 2 (corresponding to control unit connector PIN 1); if there is a short circuit, restore the wiring harness.

### **IDLE VALVE**

#### **Function**

Check the minimum engine speed depending on the temperature and different load conditions.

#### **Pin-out:**

1. Negative from control unit (valve activation)
2. Positive from control unit

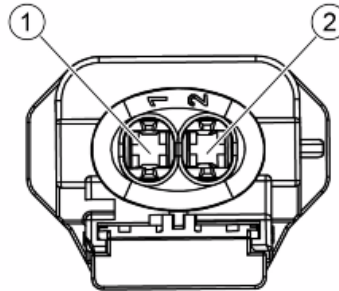

### **ELECTRICAL ERRORS**

**Low idling adjustment device voltage P0508** - open circuit or short-circuit to negative.

#### Error cause

Open circuit or short-circuit to negative: interruption of the circuit or null voltage at PIN 1 of the valve connector.

#### Troubleshooting

Open circuit:

- Perform the check of the valve and control unit connectors.
- Check the continuity of the wiring harness between the control unit connector and valve connector: Control unit PIN 17 - valve PIN 1 and control unit PIN 9 - valve PIN 1. If there is no continuity, restore the wiring harness.

Short-circuit to negative:

- Disconnect the control unit connector and the valve connector.
- Check the valve connector PIN 1 ground insulation (corresponding to control unit connector PIN 17). If there is no insulation, restore the wiring harness.
- With the valve connector disconnected and the control unit connector connected, turn ignition switch to ON and activate the component using the diagnostic tool.
- Check the voltage (for 10 seconds) at the ends of the valve connector.
- If there is no voltage, check the continuity of the wiring harness between control unit PIN 9 and valve PIN 2 and restore it if necessary.
- If the above tests provided a positive result, the valve should be replaced.

**High idling adjustment device voltage P0509** - short-circuit to positive.

#### Error cause

Short-circuit to positive: excessive voltage to PIN 17 of the control unit connector.

#### Troubleshooting

Short-circuit to positive:

- Disconnect the control unit connector and the valve connector.
- Verify that there is no short to battery positive on valve connector PIN 1 (corresponding to control unit connector PIN 17); if there is a short circuit, restore the wiring harness.
- With the valve connector disconnected and the control unit connector connected, turn ignition switch to ON and activate the component using the diagnostic tool.
- Check the voltage (for 10 seconds) at the ends of the valve connector.
- If there is no voltage, check the continuity of the wiring harness between control unit PIN 9 and valve PIN 2 and restore it if necessary.
- If the above tests provided a positive result, the valve should be replaced.

Check that the opening time of the idle check valve is below the maximum value, a higher value can be caused by soiling of the intake system.

### **Characteristic**

#### **Maximum idle check valve opening time**

20,000us (20ms)

---

### **ENGINE TEMPERATURE SENSOR**

#### **Function**

Serves the purpose of communicating the engine temperature to the control unit in order to optimise performance.

#### **Operation / Operating principle**

NTC type sensor (resistance sensor, inversely variable with temperature).

#### **Pin-out:**

1. Injection ECU
2. Control unit ground

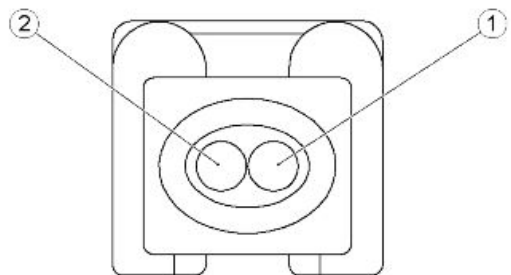

### **ELECTRICAL ERRORS**

**Low engine temperature sensor voltage P0117** - short-circuit to negative.

#### Error cause

Short-circuit to negative: null voltage at PIN 16 of the control unit connector.

#### Troubleshooting

Short-circuit to negative:

- Disconnect the sensor connector.
- Check the sensor connector PIN 1 ground insulation.
- If there is no ground insulation restore the wiring harness.

**High engine temperature sensor P0118** - open circuit or short-circuit to positive.

Error cause

Open circuit or short circuit to positive: interruption of the circuit or excessive voltage at PIN 16 of the control unit connector.

Troubleshooting

Open circuit:

- Disconnect control unit and sensor connectors and carry out the check procedure.
- Check the continuity of the wiring harness between the sensor connector and control unit connector: Sensor PIN 1- control unit PIN 16 and sensor PIN 2- control unit PIN 7. Repair the wiring harness if necessary.

Short-circuit to positive:

- With the sensor connector and the control unit disconnected, verify that the fault is a short with the battery positive of sensor connector PIN 1(or control unit PIN 16) and restore wiring.

### THROTTLE BODY POSITION SENSOR (TPS)

**Function**

In charge of sending the size of throttle opening to the control unit.

**Pin-out:**

1. Control unit ground
2. Control unit power
3. Throttle position signal

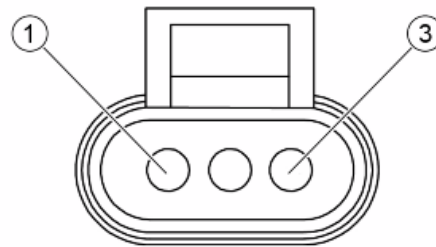

### ELECTRICAL ERRORS

**Low TPS sensor voltage input P0122** - open circuit or short-circuit to negative.

Error cause

Open circuit or short-circuit to negative: interruption of the circuit or null voltage at PIN 7, 14 or 18 of the control unit connector.

Troubleshooting

Open circuit:

- Disconnect control unit and sensor connectors and carry out the check procedure.
- Check the continuity of the wiring harness between the sensor connector and control unit connector: Sensor PIN 1 - control unit PIN 7, sensor PIN 2 - control unit PIN 18 and sensor PIN 3 - control unit PIN 14. Repair the wiring harness if necessary.

Short-circuit to negative:

- Disconnect the sensor connector.
- Check the ground insulation of the three PIN of the sensor connector.
- If there is no ground insulation restore the wiring harness.

**High sensor voltage input P0123** - short-circuit to positive.

Error cause

Short-circuit to positive: excessive voltage to PIN 7, 14 or 18 of the control unit connector.

Troubleshooting

Short-circuit to positive:

- With the sensor connector and the control unit connector disconnected, verify that the fault is shorted with the battery positive of one of the three PIN of the sensor connector and restore the wiring harness.
- 

**FOR 125 NO ABS MY2019 - VIETNAM/CHINA VERSION**

---

**THROTTLE BODY POSITION SENSOR (TPS)****Function**

In charge of sending the size of throttle opening to the control unit.

**Pin-out:**

- A. Ground reference injection control unit
- B. Injection control unit power
- C. Signal for injection control unit

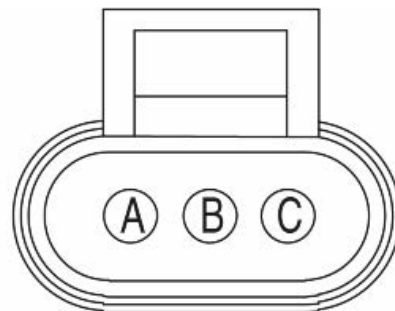
**ELECTRICAL ERRORS**

**Low TPS sensor voltage input P0122** - open circuit or short-circuit to negative.

Error cause

Open circuit or short-circuit to negative: interruption of the circuit or null voltage at PIN 7, 14 or 18 of the control unit connector.

Troubleshooting

Open circuit:

- Disconnect control unit and sensor connectors and carry out the check procedure.
- Check the continuity of the wiring harness between the sensor connector and control unit connector: Sensor PIN A - control unit PIN 7, sensor PIN B - control unit PIN 18 and sensor PIN C - control unit PIN 14. Repair the wiring harness if necessary.

Short-circuit to negative:

- Disconnect the sensor connector.
- Check the ground insulation of the three PIN of the sensor connector.
- If there is no ground insulation restore the wiring harness.

**High sensor voltage input P0123** - short-circuit to positive.

Error cause

Short-circuit to positive: excessive voltage to PIN 7, 14 or 18 of the control unit connector.

Troubleshooting

Short-circuit to positive:

- With the sensor connector and the control unit connector disconnected, verify that the fault is shorted with the battery positive of one of the three PIN of the sensor connector and restore the wiring harness.

---

### FOR 125 NO ABS MY2019 - VIETNAM/CHINA VERSION

---

#### INJECTION WARNING LIGHT

##### Function

Indicates a fault of the injection system.

##### Instrument panel connector pin-out:

1. RoBi - Oil pressure warning light
2. Gr - MODE button
3. Ro - Left turn lights indicator
4. BiBl - Right turn light indicator
5. Vi - High beam warning light
6. NC
7. NC
8. NeVe - Speed sensor
9. NC
10. NC
11. NC
12. BiVe - Fuel level sensor
13. NC
14. Az - Speed sensor
15. NC
16. MaBi - injection warning light
17. Ne - Ground
18. Gi - Immobilizer warning light
19. GiNe - Key powered
20. RsGr - Battery supply

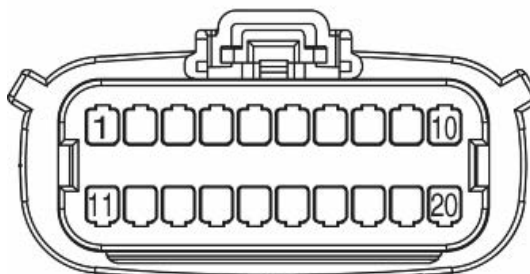

#### ELECTRICAL ERRORS

**Low MIL warning light voltage P1651** - open circuit or short-circuit to negative.

##### Error cause

Open circuit or short-circuit to negative: interruption of the circuit or null voltage at PIN 2 of the control unit connector.

##### Troubleshooting

Open circuit:

- Disconnect the instrument panel connectors and of the control unit and perform the check procedure.
- Check the continuity of the wiring harness between the control unit connector and instrument panel connector: Control unit PIN 2 - Instrument panel PIN 16. Repair the wiring harness if necessary.

Short-circuit to negative:

- Disconnect the instrument panel connectors and of the control unit and perform the check procedure.
- Check the instrument panel PIN 16 from ground insulation.
- If there is no ground insulation restore the wiring harness.

**High MIL warning light voltage P1652** - short-circuit to positive.

#### Error cause

Short-circuit to positive: excessive voltage at PIN 2 of the control unit connector.

#### Troubleshooting

Short-circuit to positive:

- Disconnect the instrument panel connectors and of the control unit and perform the check procedure.
- Verify that the fault is shorted with the battery positive of instrument panel connector PIN 16 (or control unit connector PIN 2) and restore the wiring harness.

If the above tests provided a positive result, proceed with the following check:

- Verify, with the key turned ON, the presence of voltage on the instrument panel connector PIN 16, otherwise check the related wiring harnesses, the ignition switch contacts and the fuses 2 and 3.

---

## ELECTRICAL ERRORS

### **Smearred throttle body P1003**

#### Error cause

The control unit shows the error P1003 (ATT or MEM) once it receives an abnormal increase of the engine idling speed.

#### Troubleshooting

- Remove the throttle body and thoroughly clean it as described in the section «Injection > Throttle body removal».
- After refitting, delete the error and reset the adaptive parameters.
- Keep the engine running at idle speed for 15 minutes.

---

## INJECTION WARNING LIGHT

### **Function**

Indicates a fault of the injection system.

### **Instrument panel connector pin out «B»:**

1. Fuel reserve warning light
2. Oil pressure warning light
3. High beam warning light
4. Injection warning light

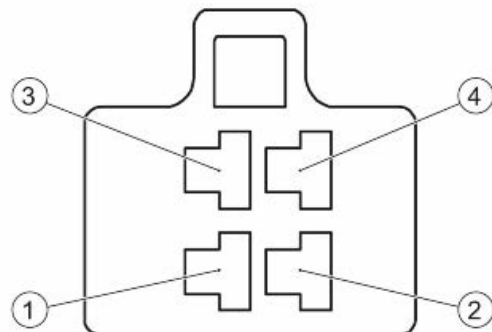

## ELECTRICAL ERRORS

**Low MIL warning light voltage P1651** - open circuit or short-circuit to negative.

#### Error cause

Open circuit or short-circuit to negative: interruption of the circuit or null voltage at PIN 2 of the control unit connector.

#### Troubleshooting

Open circuit:

- Disconnect the instrument panel connectors «B» and of the control unit and perform the check procedure.
- Check the continuity of the wiring harness between the control unit connector and instrument panel connector: Control unit PIN 2 - Instrument panel PIN 4. Repair the wiring harness if necessary.

Short-circuit to negative:

- Disconnect the instrument panel connectors «B» and of the control unit and perform the check procedure.
- Check the instrument panel PIN 4 from ground insulation «B».
- If there is no ground insulation restore the wiring harness.

**High MIL warning light voltage P1652** - short-circuit to positive.

#### Error cause

Short-circuit to positive: excessive voltage at PIN 2 of the control unit connector.

#### Troubleshooting

Short-circuit to positive:

- Disconnect the instrument panel connectors «B» and of the control unit and perform the check procedure.
- Verify that the fault is shorted with the battery positive of instrument panel connector PIN 4 (or control unit connector PIN 2) and restore the wiring harness.

If the above tests provided a positive result, proceed with the following check:

- Verify, with the key turned ON, the presence of voltage on the instrument panel connector PIN 4, otherwise check the related wiring harnesses, the ignition switch contacts and the fuses 2 and 3.

---

## LAMBDA PROBE

### Function

In charge of telling the control unit whether the mixture is lean or rich.

### Operation / Operating principle

Based on the difference of oxygen in the exhaust fumes and the environment, this generates voltage which is read and interpreted by the injection control unit. It does not require an external supply source but, in order to work properly, it should reach a high operating temperature: that is why there is a heating circuit inside.

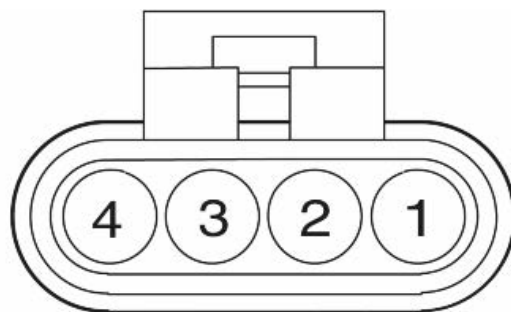

**Pin-out:**

1. Sensor signal -
2. Heater ground
3. Sensor signal +
4. Heater power

**ELECTRICAL ERRORS**

**Low lambda probe voltage P0131** - short-circuit to negative.

Error cause

Short-circuit to negative: null voltage at PIN 13 of the control unit connector.

Troubleshooting

Short-circuit to negative:

- Disconnect the connector of the probe and the control unit connector and carry out the check procedure.
- Check the sensor connector PIN 3 from ground insulation. If there is no insulation, restore the wiring harness.

**High Lambda probe voltage P0132** - short-circuit to positive.

Error cause

Short-circuit to positive: excessive voltage to PIN 13 of the control unit connector.

Troubleshooting

Short-circuit to positive:

- Disconnect the control unit connector and the probe connector and perform the check procedure.
- Verify that there is no short to battery positive on sensor connector PIN 3 (corresponding to control unit connector PIN 13); if there is a short circuit, restore the wiring harness.

**Low lambda probe voltage P0031** - open circuit or short-circuit to negative.

Error cause

Open circuit or short-circuit to negative: interruption of the circuit or null voltage at PIN 3 of the control unit connector.

Troubleshooting

Open circuit:

- Disconnect the control unit connector and the heater connector and perform the check procedure.
- Check the continuity of the wiring harness between the sensor connector and control unit connector: Control unit PIN 3, sensor PIN 2 and control unit PIN 9 - sensor PIN 4. Repair the wiring harness if necessary.
- If the wiring harness is intact and the error persists, proceed with the following checks.

Short-circuit to negative:

- Disconnect the control unit connector and the heater connector and perform the check procedure.
- Check the sensor connector PIN 2 ground insulation (corresponding to control unit connector PIN 3). If there is no insulation, restore the wiring harness.

**High heater lambda probe voltage P0032** - short-circuit to positive.

Error cause

Short-circuit to positive: excessive voltage to PIN 3 of the control unit connector.

Troubleshooting

Short-circuit to positive:

- Disconnect the control unit connector and the heater connector and perform the check procedure.
  - Verify that there is no short to battery positive on sensor connector PIN 2 (corresponding to control unit connector PIN 3); if there is a short circuit, restore the wiring harness.
-

# INDEX OF TOPICS

ENGINE FROM VEHICLE

MOT VE

## Exhaust assy. Removal

**CAUTION**

**FREE THE CABLES OF THE LAMBDA PROBE BEFORE REMOVING THE SILENCER, PUTTING THIS CABLE HARNESS UNDER AN EXCESSIVE VOLTAGE MAY DAMAGE IT.**

- Remove the lambda probe wiring harness cover.



- Disconnect the probe.



- Release the lambda probe cable harness.



- Release the nuts fixing the silencer to the head.

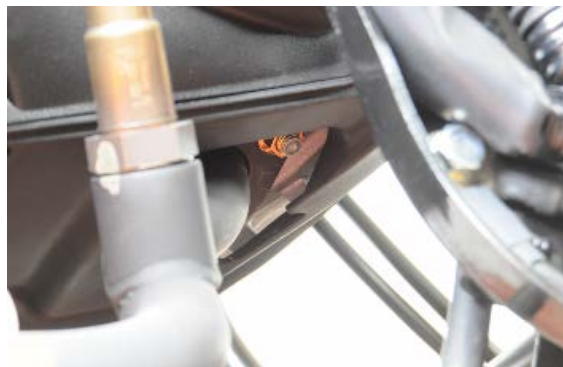

- Release the nuts fixing the silencer to the crankcase.



- To refit, proceed in reverse order, tightening the nuts and screws to the specified tightening torques.

### Locking torques (N\*m)

Silencer to crankcase fixing screws 24 to 27 Nut fixing silencer to cylinder head 16 - 18

## Removal of the engine from the vehicle

### CAUTION



### SUPPORT THE VEHICLE ADEQUATELY.

- Remove the helmet compartment.
- Remove the side fairings.
- Remove the footrest.
- Remove the protection of the lambda and stator connectors.
- Disconnect the air delivery pipe to the filter body.



- Remove the fastening screws of the air intake of the variator.



- Disconnect the frame engine-ground.



- Disconnect the engine idling valve connector.

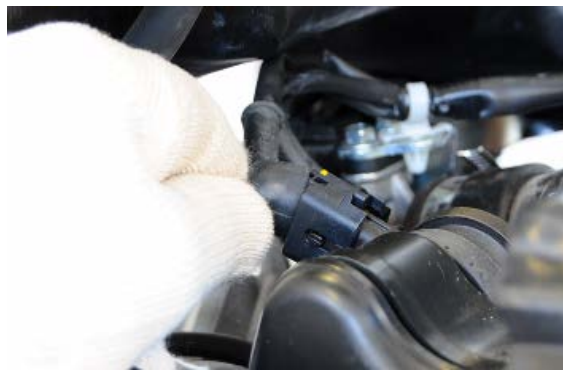

- Disconnect the engine temperature sensor.



- Disconnect the injector.



- Remove the injector support bracket wiring harness fastening clamp.



- Disconnect the throttle position sensor.



- Disconnect the H.V. coil.

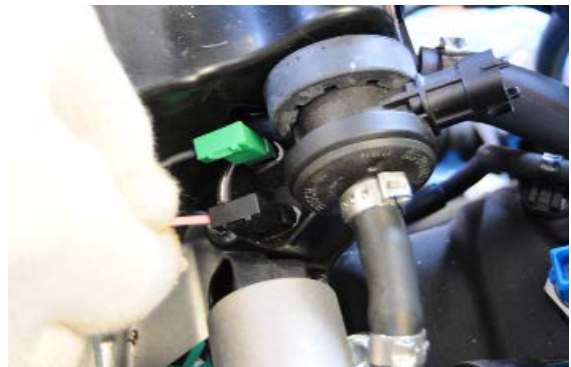

- Remove the wiring harness securing bracket located above the starter motor..

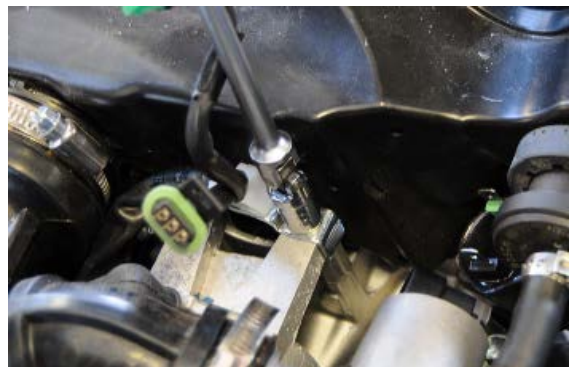

- Remove the starter motors ground.



- Remove the starter motor power.



- Loosen the clamp fastening the throttle body to the intake d.



- Remove the filter housing from the crankcase.



- Remove the fastening clamp of the vapour recovery pipe.



- Disconnect the flywheel connector.



- Remove the rear screw fixing the wiring harness support bracket.

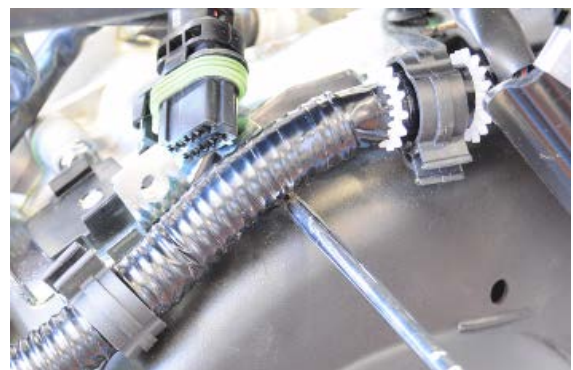

- Remove the front screw fixing the wiring harness support bracket.



- Unscrew the rear brake adjuster nut.

- Release the rear brake cable from the fixing bracket to the crankcase.



- Remove the retainer fixing the cable to the crankcase.



- Remove the fastener clamp of the wiring harness to the rear mudguard.



- Remove the bottom screw fixing the rear right shock absorber.



- Remove the screw securing the swing arm-engine.



- Remove the screw securing the swing arm-frame.



- Remove the fixing screw from the bracket with silent block to the frame.



- To refit, proceed in reverse order, observing the prescribed locking torques.

### Locking torques (N\*m)

**Screw fixing plate with silent block - frame 36 - 44 Frame-swinging arm bolt 40 - 45 Swinging arm pin - engine 40 - 45 Rear shock absorber - bracket 40 - 45**

#### CAUTION



WHEN FITTING THE SILENCER SUPPORT BRACKET, IT IS NECESSARY TO GREASE THE INSIDE OF THE DUST GAITER AND THE SEALING LIP WITH THE RECOMMENDED PRODUCT AND FILL THE THROAT UNDER THE BEARING.

### Recommended products

**Calcium based grease Calcium grease**

Smooth-textured appearance; Ivory colored Specification TL 9150 066, symbol NATO G 460

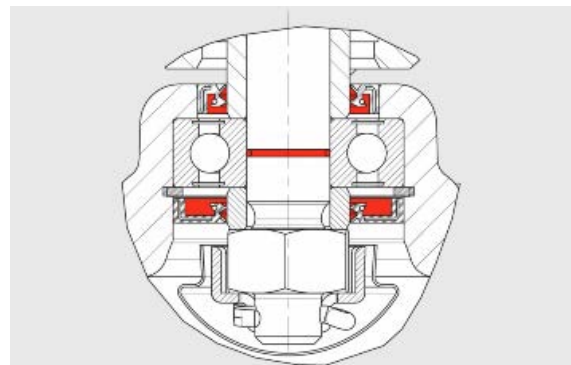

**Characteristic**

**Product quantity on inside dust gaiter**

~ 1 cm<sup>3</sup>

**Product quantity on outside dust gaiter**

~ 3 cm<sup>3</sup>

---

# INDEX OF TOPICS

ENGINE

MOT

**N.B.**

THE UNITS OF MEASUREMENT CONTAINED IN THIS CHAPTER ARE EXPRESSED IN TERMS OF THE DECIMAL METRIC SYSTEM. TO REFER TO THE UNIT OF MEASUREMENT EXPRESSED IN TERMS OF THE ANGLO-SAXON SYSTEM, SEE THE «CHARACTERISTICS» CHAPTER.

This section describes the operations to be carried out on the engine and the tools to be used.

**Automatic transmission****Transmission cover**

- Remove the air duct.
- Remove the plastic cover of the rear wheel axle.
- Insert the specific tools, rotate the engine until the driven pulley stops.

**Specific tooling**

**020994Y Driven pulley lock**



- Unscrew the wheel axle nut.



- Remove the specific tool, the wheel axle nut and collect the washer.



- Unscrew the ten screws fixing the engine and remove the transmission cover.



- Collect the gasket on the engine oil sump.



## Air duct

- Remove the plastic cover.



- Unscrew the screws indicated and remove the duct.



---

## Removing the driven pulley shaft bearing

- Remove the Seeger ring.

**CAUTION**

PLACE THE COVER ON A SURFACE, REMOVING OR EXCLUDING THE ALIGNMENT DOWELS.



- Support the transmission cover adequately.
- Using appropriate tools, remove the bearing.

**Specific tooling**

020376Y Adaptor handle

020357Y 32 x 35-mm Adaptor

020412Y 15-mm guide



---

## Refitting the driven pulley shaft bearing

- Use the heat gun to heat the inner part of the lid.
- Using the equipment plant a new bearing, apply grease on the adapter and guide in order to maintain the position of the bearing during operation on the vertical axis.

**Specific tooling**

020151Y Air heater

020376Y Adaptor handle

020358Y 37 x 40 mm Adaptor

020412Y 15-mm guide



- Insert the Seeger ring.
- Insert the alignment dowels if removed during disassembly.



## Removing the driven pulley

- Undo the clutch fixing screw, recovering the lining.
- Remove the clutch drum.
- Remove the driven pulley.



## Inspecting the clutch drum

- Make sure that the clutch housing is not worn or damaged.
- Measure the clutch housing inside diameter.

### Characteristic

#### Clutch housing max. value

Max. value:  $\varnothing$  134.5 mm

#### clutch housing standard value

Standard value:  $\varnothing$  134 - 134.2 mm

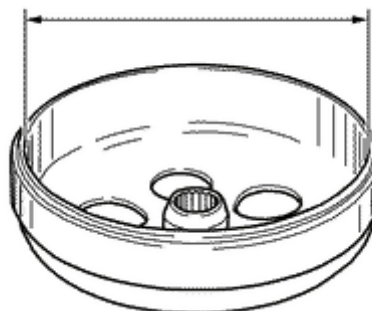

### Checking the bell working surface eccentricity

- Install the bell on a driven pulley shaft using 2 bearings (inside diameter: 15 and 17 mm).
- Lock with the original spacer and nut.
- Place the bell/shaft unit on the support to check the crankshaft alignment.

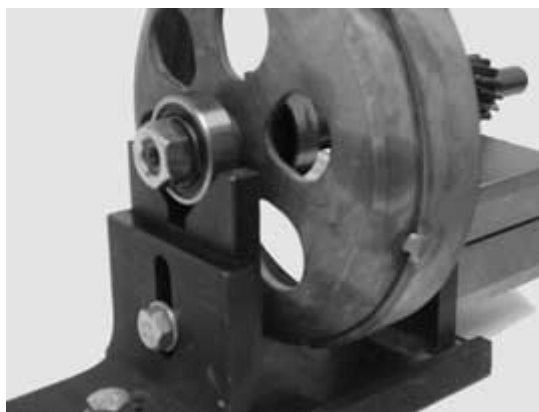

- Using a dial gauge and the magnetic base, measure the bell eccentricity.
- Repeat the measurement at 3 positions (Central, internal, external).
- In case of faults, replace the bell.



### Specific tooling

**020074Y Support base for checking crankshaft alignment**

**020335Y Magnetic mounting for dial gauge**

### Characteristic

**clutch housing check: Limit eccentricity.**

Admissible limit eccentricity: 0.15 mm

## Removing the clutch

- Prepare the locking tool for the driven pulley with the pins half-screwed in the tool set to «C».
- Introduce the adapter ring 11 with the chamfering facing the inside of the tool.



- Fit the driven pulley unit in the tool so as the bolt get into the masses clutch support holes. Afterwards make the support screw make contact with a minimum force.
- Using the specific wrench, inserted 46 mm from the side, remove the clutch central locking nut.



- Separate the components of the driven pulley.

### CAUTION

THE TOOL MUST BE FIRMLY FIXED IN THE VICE AND THE CENTRAL SCREW MUST NOT BE TIGHTENED WITH EXCESSIVE TORQUE AS THIS MAY DAMAGE THE PULLEY OR DEFORM THE SPECIFIC TOOL.

### Specific tooling

**020444Y Tool for installing/removing clutch on/from driven pulley**

**020444Y011 adapter ring**

**020444Y009 wrench 46 x 55**



## Inspecting the clutch

- Check the thickness of the clutch mass friction material.
- The masses must exhibit no traces of lubricants; in that case, check the driven pulley unit seals.

### N.B.

UPON RUNNING-IN, THE MASSES MUST EXHIBIT A CENTRAL FACING SURFACE AND MUST NOT BE DIFFERENT FROM ONE ANOTHER. VARIOUS CONDITIONS CAN CAUSE THE CLUTCH TO TEAR.

### CAUTION

DO NOT USE TOOLS TO OPEN THE MASSES TO AVOID VARIATION IN THE RETURN SPRING LOAD.

### Characteristic

#### Check minimum thickness

1 mm

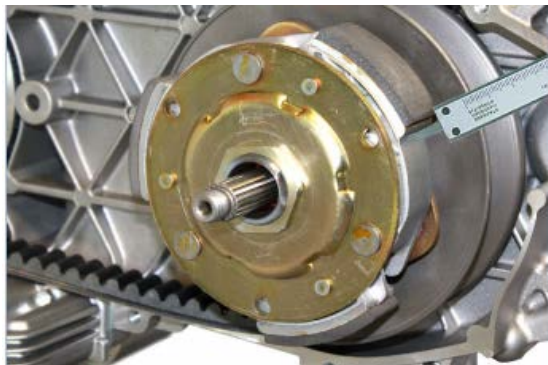

## Pin retaining collar

- Simultaneously turn and pull the collar manually to remove it.

### N.B.

USE TWO SCREWDRIVERS IF YOU HAVE ANY DIFFICULTY.

### N.B.

BE CAREFUL NOT TO PUSH THE SCREWDRIVERS IN TOO FAR TO AVOID DAMAGE THAT COULD COMPROMISE THE O-RING SEAL.



## Inspecting the driven fixed half-pulley

- Measure the outside diameter of the pulley bushing.

### Characteristic

#### Standard diameter:

Ø 40.1 ± 0.05 mm



## Removing the driven half-pulley bearing

- Remove the retainer ring using two flat blade screwdrivers.
- Using a hammer and pin, knock the ball bearing out as shown in the figure.
- Remove the bearing and the rollers with the specific extractor.

### N.B.

REST THE DRIVEN PULLEY ON A WOODEN SURFACE TO AVOID DAMAGING ITS THREADED BUSHING. ALSO DO THIS UPON REMOVAL.

### Specific tooling

001467Y008 Clamp to extract 17 mm  $\varnothing$  bearings

001467Y009 Bell for OD 42-mm bearings

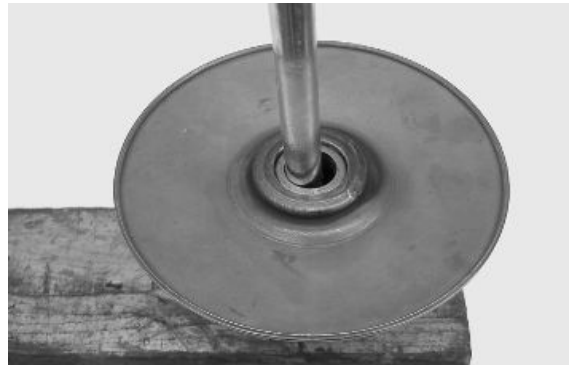

## Refitting the driven half-pulley bearing

- Assemble a new roller bearing using the specific punch, fit the bearing with the label facing outward and insert it completely up to the punch on the half-pulley.

### N.B.

REST THE DRIVEN PULLEY ON A WOODEN SURFACE TO AVOID DAMAGING ITS THREADED BUSHING. ALSO DO THIS UPON REMOVAL.

### Specific tooling

020424Y Driven pulley roller casing fitting punch

- To assemble the new ball bearing, insert it fully down in its seat with the specific punch and finally fit the seeger ring.

### Specific tooling

020375Y 28 x 30 mm adaptor

020376Y Adaptor handle

020439Y 17-mm guide



---

## Refitting the driven pulley

---

- Check that the faying surfaces of the 2 half-pulleys and the belt do not show any signs of wear, scoring or grease.
- Insert the new oil seals and O-rings on the movable half-pulley.
- Fit the half-pulley on the bushing with the appropriate protection sheath.
- Make sure the pins and collar are not worn, refit the pins and the collar.
- Use a greaser with a curved spout to lubricate the driven pulley unit with around 6 g of grease. This operation must be done through one of the holes inside the bushing until grease comes out of the opposite hole. This operation is necessary to avoid the presence of grease beyond the O-rings.

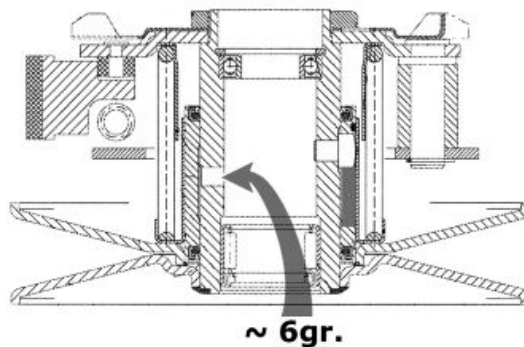

### Specific tooling

020263Y Driven pulley assembly sheath

---

## Inspecting the clutch spring

---

- Measure the length of the spring when it is relaxed.

**Characteristic**  
**Standard length:**

106 mm

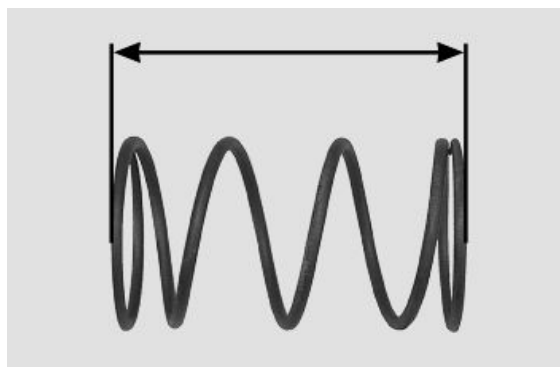

---

## Refitting the driven pulley

---

- Reassemble the clutch housing and spacer.



---

## Drive-belt

- Make sure the drive belt is not damaged and does not show abnormal wear.
- Replace according to the scheduled maintenance table.

---

## Removing the driving pulley

---

- using specific tools, lock the driving pulley and loosen the nut.

### Specific tooling

020442Y Pulley lock wrench



- remove the flat washer and the cup washer.



- remove the stationary half-pulley and the washer.



- disengage the belt.
- remove the complete roller housing.



## Inspecting the rollers case

- Check that the internal bushing shown in the figure is not abnormally worn and measure inner diameter A.
- Measure outer diameter B of the pulley sliding bushing shown in the figure.
- Check that the rollers are not damaged or worn.
- Check the sliding shoes for the variator back-plate are not worn.
- Check the wear of the roller housings and of the belt facing surfaces on both pulley halves.



- Check that stationary driving pulley does not show signs of abnormal wear on the grooved edge and on the surface in contact with the belt.

**CAUTION**

**DO NOT LUBRICATE OR CLEAN SINTERED BUSHINGS**

**Characteristic**

**movable driving half-pulley bushing: Standard Diameter**

26.000 - 26.021 mm

**Sliding bushing**

Ø26 (-0.020 -0.041)mm

**Characteristic**

**CVT rollers ø 19 mm**

Wear limit ø 18.4 mm



## Refitting the driving pulley

- perform the operations in reverse order of disassembly.

**CAUTION**

**INSERT THE ROLLERS WITH THE LARGEST SUPPORT SURFACE ACCORDING TO THE DIRECTION OF ROTATION.**



- tighten the torque using the specific tool to lock the pulley.

**CAUTION**

**DURING THE INSTALLATION PAY SPECIAL ATTENTION TO THE ASSEMBLY OF THE SPRING WASHER, AS SHOWN IN FIGURE.**

**Locking torques (N\*m)**

**driving pulley retainer nut 75 - 83**



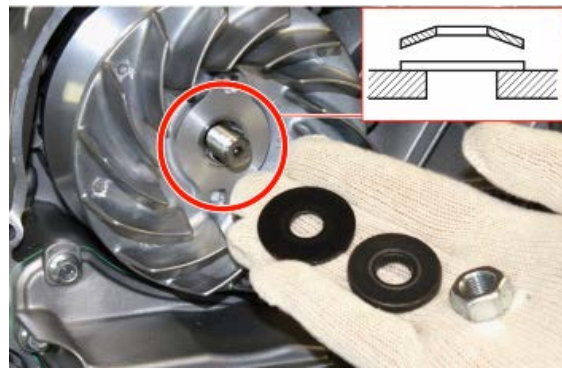

## Refitting the transmission cover

Follow the removal steps but in reverse order; be careful to tighten to the prescribed torques.

### Locking torques (N\*m)

Clutch cover retainer screws 10.8 - 12.8

## End gear

## Removing the hub cover

- Use a container large enough to recover the final reduction oil. Unscrew the indicated screw and recover the aluminium seal.
- Unscrew the oil filler screw in order to facilitate bleeding.

### Recommended products

Transmission oil 80W-90 Lubricant for gear-boxes and transmissions.

SAE 80W-90 API GL-4

### Characteristic

#### Hub oil quantity

325 cm<sup>3</sup>





- Remove the brake shoe.
- Unscrew the eight hub cap fixing screws.

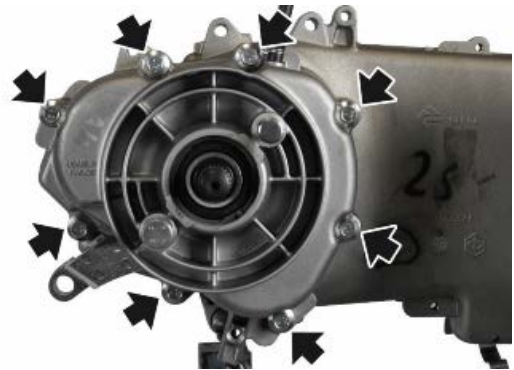

- Remove the final reduction cap complete with the wheel axle, being careful not to drop the intermediate gear.



## Removing the wheel axle

- Remove the intermediate gear.
- Remove the wheel axle.



---

## Removing the hub bearings

### Removing the clutch shaft bearing

- Remove the Seeger ring.
- Remove the oil seal from the opposite side.
- Remove the bearing working from the external side and using the specific tools.

### Specific tooling

020376Y Adaptor handle

020363Y 20-mm guide

020357Y 32 x 35-mm Adaptor

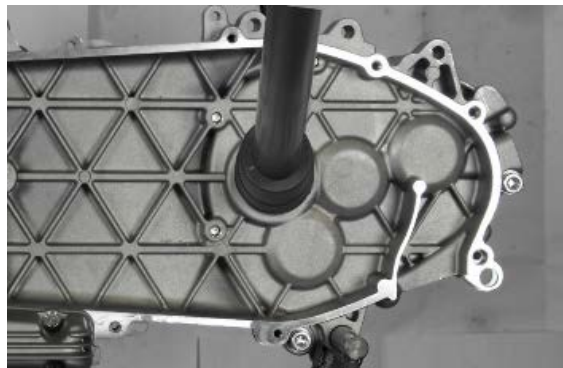

---

### Removing the intermediate gear bearing

- Remove the bearing using the specific tools

### Specific tooling

001467Y009 Bell for OD 42-mm bearings

001467Y013 Calliper to extract  $\varnothing$  15-mm bearings



---

### Wheel axle bearing removal

- Remove the bearing using the specific tools

### Specific tooling

001467Y009 Bell for OD 42-mm bearings

001467Y013 Calliper to extract  $\varnothing$  15-mm bearings



## Removing the wheel axle bearings

- Support the hub cover properly to avoid damaging the sealing surface with the crankcase.
- Remove the Seeger ring from the outside.
- Operating on the inside, remove the oil seal.
- Remove the wheel axle bearing using the specific tool.

### Specific tooling

020376Y Adaptor handle

020364Y 25-mm guide

020359S 42 x 47 mm Adaptor

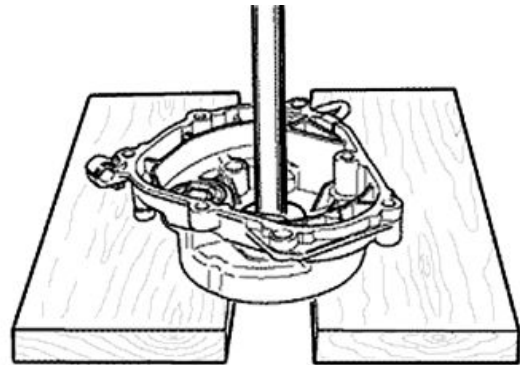

## Removing the intermediate gear bearing

- Remove the bearing using the specific tools

### Specific tooling

001467Y013 Calliper to extract  $\varnothing$  15-mm bearings

001467Y009 Bell for OD 42-mm bearings



## Inspecting the hub shaft

- Check the three shafts and the intermediate gear for wear or distortion of the toothed surfaces, the bearing housings, and the oil seal housings.
- In case of faults, replace the damaged parts.

### Characteristic

**Driven pulley shaft**

A: 22(-0.01 -0.02)mm

**Wheel axle**

B: 15(-0.010 -0.020)mm

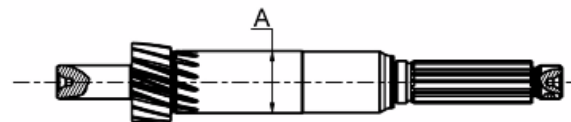

C: 25(-0.007 -0.020)mm

**Intermediate gear**

D: 15(-0.01 -0.02)mm

E: 15(-0.01 -0.02)mm

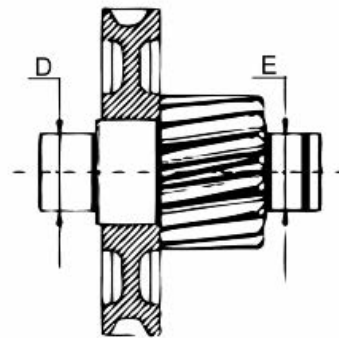
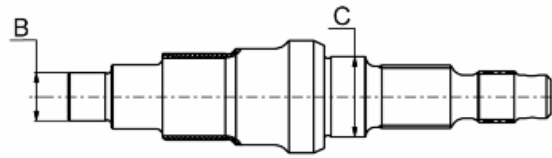

---

### Inspecting the hub cover

- Check that the fitting surface is not dented or distorted.
- Check the bearing bearings.
- In case of faults, replace the damaged components.

---

### Refitting the driven pulley shaft bearing

- Use the heat gun to heat the bearing seat.
- Set a new bearing using the specific equipment.
- Insert a locking seeger.

**Specific tooling**

**020151Y Air heater**

**020376Y Adaptor handle**

**020360S 52 x 55 mm adaptor**

**020363Y 20-mm guide**





#### Fitting the transmission shaft bearing

- Use the heat gun to heat the bearing seat.
- Set a new bearing using the specific equipment.

#### Specific tooling

020151Y Air heater

020376Y Adaptor handle

020359Y 42 x 47 mm Adaptor - For main bearings and wheel axle

020412Y 15-mm guide



#### Fitting the Wheel axle bearing

- Use the heat gun to heat the bearing seat.
- Set a new bearing using the specific equipment.

#### Specific tooling

020151Y Air heater

020376Y Adaptor handle

020359Y 42 x 47 mm Adaptor - For main bearings and wheel axle

020412Y 15-mm guide



### Refitting the hub cover bearings

#### Fitting the Wheel axle bearing

- Use the heat gun to heat the bearing seat.
- Plant a new bearing using the equipment, apply grease on the adaptor and guide in order to maintain the position of the bearing during operation on the vertical axis.
- Insert the Seeger ring.

#### Specific tooling



020151Y Air heater

020376Y Adaptor handle

020360S 52 x 55 mm adaptor

020364Y 25-mm guide



### Fitting the transmission gear bearing

- Use the heat gun to heat the bearing seat.
- Using the equipment set a new bearing.

### Specific tooling

020151Y Air heater

020376Y Adaptor handle

020359S 42 x 47 mm Adaptor

020412Y 15-mm guide



## Refitting the hub bearings

- Insert the gears in the cover in order to prevent abnormal movements during insertion into the engine.
- Insert the wheel axis.



## Refitting the hub cover

- Clean the engine crankcase and reduction cover surfaces adequately.
- Working in reverse with respect to the disassembly, insert the command pinion and the intermediate gear into the hub box.
- Pay attention to the correct positioning of the alignment dowels.
- Insert the gasket.

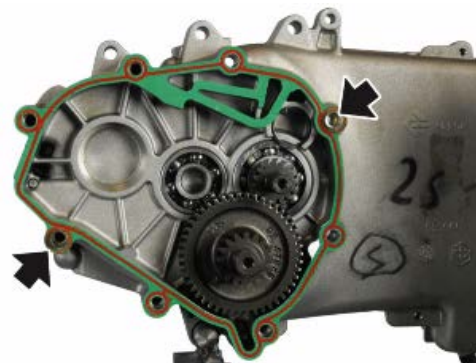

- Insert the gears of the reduction unit in the reduction cover and tighten the screws to the specified torque, tightening in crossed sequence.
- Check the correct the tightening drainage screw.

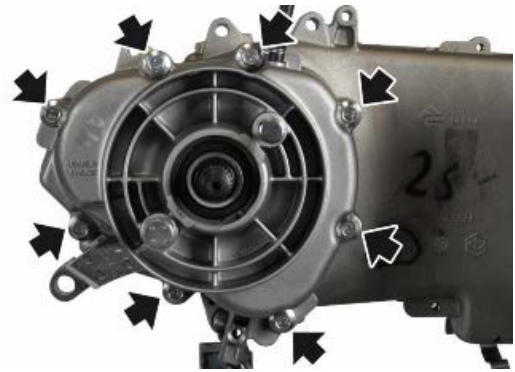

**Locking torques (N\*m)**

**Hub cover fixing screws 23.53 to 26.48 Reduction unit oil drainage screw 15 to 17**

- Restore the level of oil inside reduction unit with the recommended product, acting on the filler screw until touching.
- Tighten to the specified torque.



**Recommended products**

**Transmission oil 80W-90 Lubricant for gearboxes and transmissions.**

SAE 80W-90 API GL-4

**Characteristic**

**Hub oil quantity**

325 cm<sup>3</sup>

**Locking torques (N\*m)**

**Oil relief screw 15 to 17**

**Flywheel cover**

**Cooling hood**

- Unscrew the five indicated screws and remove the cooling cap.



---

## Cooling fan

- Remove the front part of the fan, unscrewing the three fixing screws.



- Using the specific tool, unscrew the cooling fan fixing screw.
- Remove the fan.
- Recover the wrench.

### Specific tooling

020442Y Pulley lock wrench



---

## Removing the hub cover

- Remove the oil dipstick.
- Remove the sensor connector.
- Unscrew the eleven fixing screws of the flywheel cover.



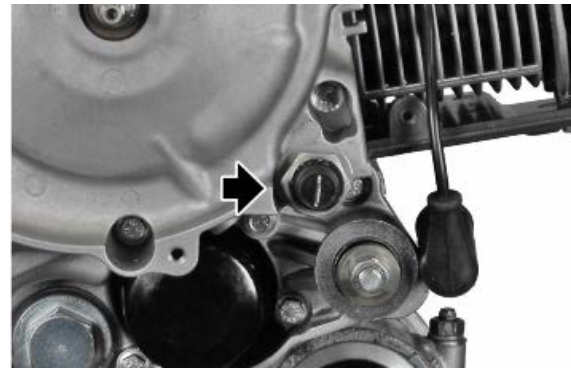

- Remove the cover.
- Remove the gasket.
- Pay attention to the alignment dowels.



## Removing the stator

- Remove the flywheel cover.
- Unscrew the 2 flywheel fixing screws and the four pick-up fixing screws and wiring harness retainer screws.

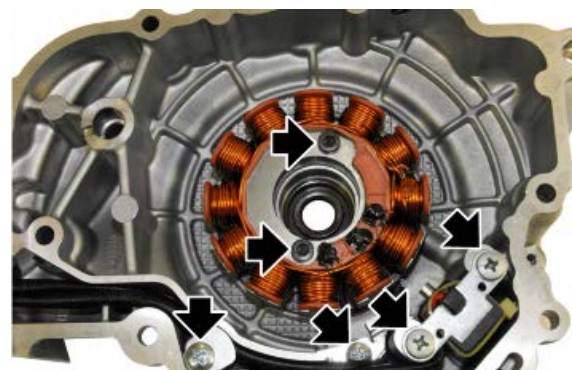

- Remove the flywheel and the pick-up complete with wiring harness.

## Refitting the stator

- Refit the stator and flywheel carrying out the removal procedure in reverse, tightening the retainers to the specified torque.
- Respect the operation of the pick-up.

### Locking torques (N\*m)

**Stator fixing screws 8 to 10 Pickup fixing screws 3 - 4**

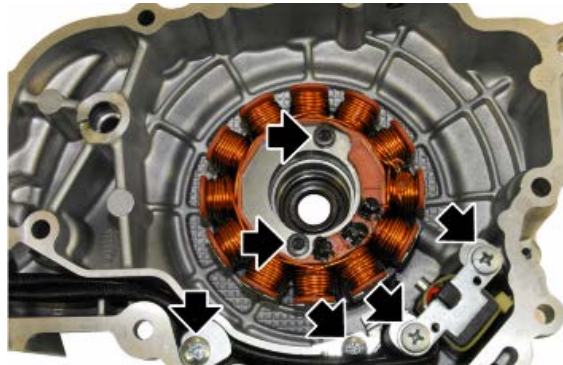

## Refitting the flywheel cover

- Fit the gasket and be careful with the two alignment dowels.



- Tighten the screws and tighten to the specified torque.

### CAUTION



TO AVOID DAMAGING THE OIL SEAL, USE THE SPECIFIC TOOL PRIOR TO POSITIONING THE FLYWHEEL COVER.

### Specific tooling

020940Y Flywheel cover oil seal gasket

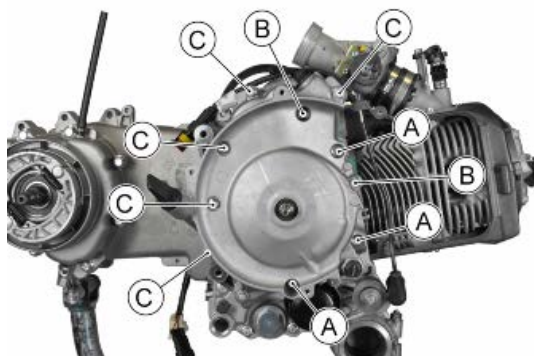

### FLYWHEEL COVER SCREWS

POSITION	DIMENSIONS	TORQUE (Nm)
A	M6x90	11 to 13
B	M6x35	11 to 13
C	M6x30	11 to 13

## Flywheel and starting

---

## Removing the starter motor

---

- Undo the two fixing screws and remove the starter motor.



---

## Removing the flywheel magneto

---

- Undo the screw indicated and remove the plate.



- Install the specific tool and unscrew the retainer nut of the flywheel, recovering the washer.

### Specific tooling

020939Y Flywheel retainer



- Before screwing in the flywheel extractor the protection tool provided in the specific tool must be positioned.

**Specific tooling****020933Y Flywheel extractor**

- Acting on the extractor, remove the flywheel together with the starting sprocket and intermediate gear.



---

**Inspecting the flywheel components**

- Check the integrity of the internal plastic parts of the flywheel and the Pick-up control plate.
- 
- Check the integrity of the internal plastic parts of the flywheel and the Pick-up control plate.
- 

**Refitting the flywheel magneto**

- Perform the procedure in reverse order of disassembly, taking care to tighten to specified torque.

**Locking torques (N\*m)****Flywheel fixing nut 100 - 110**

---

---

## Refitting the starter motor

- Fit a new O-ring on the starter motor and lubricate it.
- Fit the starter motor on the crankcase and lock the two screws to the prescribed torque.

### Locking torques (N\*m)

Starter screws 10.8 - 12.8

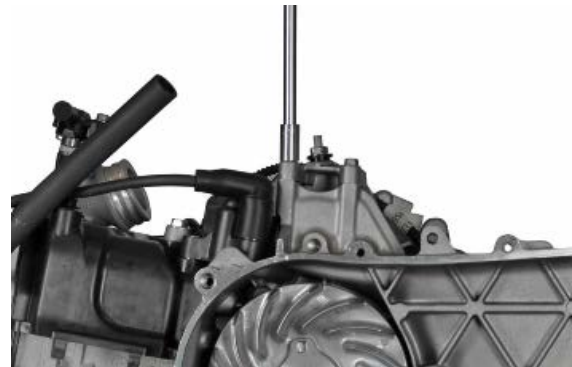

---

## Cylinder assy. and timing system



---

## Removing the intake manifold

- The intake manifold is positioned on the head, loosen the clamps and remove the sleeve connecting to the throttle body.
- Undo the three manifold fixing screws and remove it.



---

## Removing the rocker-arms cover

- Remove the protective cover, undoing the three screws.



- Remove the engine temperature sensor.
- Undo the screw indicated.
- remove the upper part of the cover.



- Unscrew the four screws and remove the tappet cover.





## Removing the timing system drive

- Before carrying out operations on the timing system we recommend positioning the engine at TDC in compression. To do this use the specific tools.
- Use the holes on the engine crankcase to secure the tool.
- Position the specific tool in the window between the flywheel pick-up references as illustrated in the figure.



### Specific tooling

#### 020941Y Crankshaft timing adjustment tool



- First loosen the tensioner and unscrew the fixing screws.
- Remove the tensioner complete with gasket.





- Undo the two screws on the timing system gear.



- Disengage the timing system gear and remove the camshaft control sprocket.
- Remove the cylinder as described in section «**Engine/Piston cylinder disassembly**»

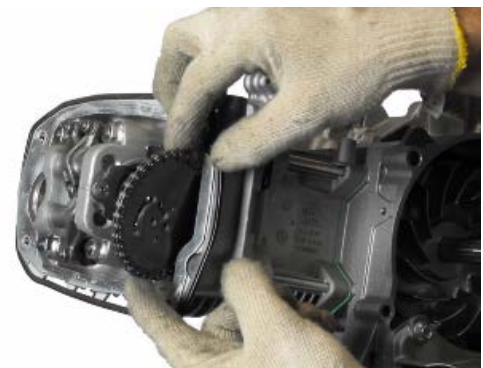

After removing the head the camshaft control components can be removed:

- Remove the inspection cover as described in sec. «**Lubrication/Main bushing oil seals removal**».
- Remove the oil pump command as described in section «**Lubrication/Oil pump/Disassembly**».
- Undo the chain tensioner pad fixing screw, remove the bushing and the slider.



- Remove the chain tensioner pad.



- Remove the control gear.
- Remove the seal OR.
- Remove the flat washer.



**CAUTION**

REMEMBER TO CORRECTLY POSITION THE SEAL OR IN THE REFITTING PHASE.

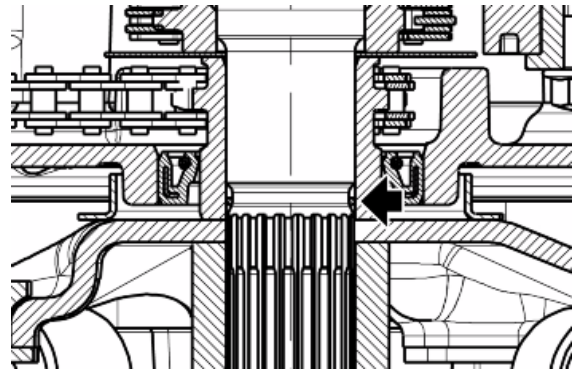

- Release the timing chain from the crankshaft.
- Remove the control gear.

**See also**

[Removal](#)  
[Removing the cylinder - piston assy.](#)

**Removing the cam shaft**

- Undo the camshaft lock screw.



- Remove the lock.
- Remove the two pins and the rockers.
- Remove the camshaft.





---

## Removing the cylinder head

- Gradually loosen the four screws in crossed sequence and recover the washers.
- Undo the two external screws.





- Remove the cylinder head.
- Remove the chain guide slider and the gasket.



- Remove the gasket.



N.B.



ON ASSEMBLY PAY CLOSE ATTENTION TO THE TWO DOWELS.

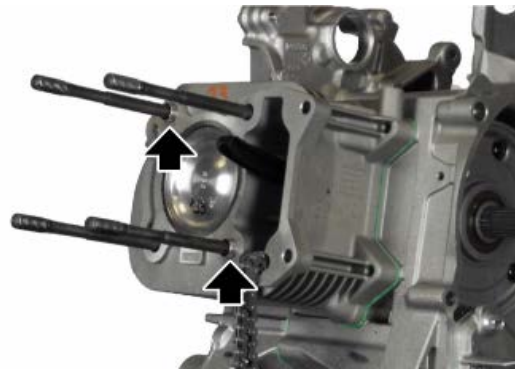

## Removing the valves

- Use the specific tool to remove the cotters, cap and spring.

**CAUTION**

PROPERLY REPLACE THE PADS AND ROCKERS SO AS TO PRESERVE THE COUPLINGS.

**CAUTION**



DURING ASSEMBLY, POSITION THE VALVE SPRINGS WITH THE GREEN COLOURED COIL FACING UPWARD.



### Specific tooling

020382Y Valve fitting/ removal tool





- Use the specific tool to remove the valve oil seal.

**Specific tooling**

**020431Y Valve oil seal extractor**

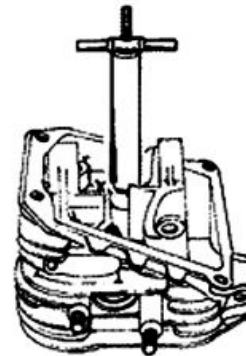

- Slide off the valve and remove the lower support.



**Removing the cylinder - piston assy.**

- Remove the cylinder, paying attention to the cylinder-crankcase alignment dowels.

**CAUTION**

**TO PREVENT DAMAGING THE PISTON, SUPPORT IT WHILE REMOVING THE CYLINDER.**

**N.B.**

**IN ORDER NOT TO DAMAGE THE BASE GASKET WITH THE PISTON LOCK FORK 020426Y DURING THE MOUNTING PHASE, IT IS RECOMMENDED TO INSERT THE ALIGNMENT DOWELS OF THE CYLINDER - CRANKCASE UNDER THE CYLINDER DURING THE ASSEMBLY.**

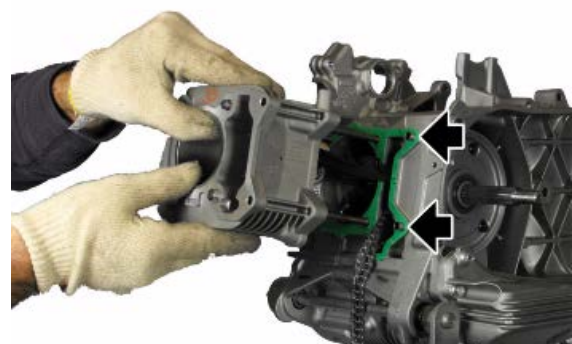

- Remove the base gasket.

- Remove the retainer rings and remove the piston.

**N.B.**

**BE CAREFUL NOT TO DAMAGE THE SEALING RINGS DURING REMOVAL.**

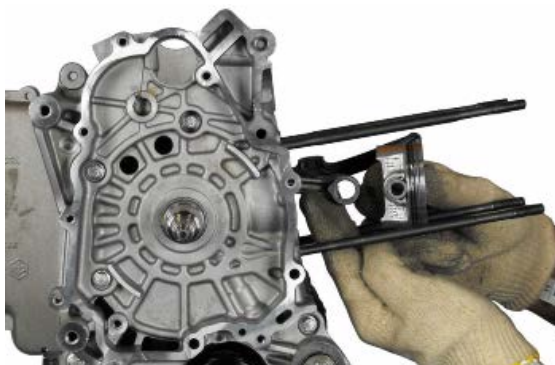

---

## Inspecting the small end

**N.B.**

**TO MEASURE WEAR LIMITS AND COUPLING CLEARANCES, SEE THE SPECIFICATIONS CHAPTER.**

**See also**

[Crankcase - crankshaft - connecting rod](#)

---

## Inspecting the wrist pin

**N.B.**

**TO MEASURE WEAR LIMITS AND COUPLING CLEARANCES, SEE THE SPECIFICATIONS CHAPTER.**

**See also**

[Cylinder - piston assy.](#)

---

## Inspecting the piston

**N.B.**

**TO MEASURE WEAR LIMITS AND COUPLING CLEARANCES, SEE THE SPECIFICATIONS CHAPTER.**

**See also**

[Cylinder - piston assy.](#)

---

## Inspecting the piston rings

**N.B.**

---

TO MEASURE WEAR LIMITS AND COUPLING CLEARANCES, SEE THE SPECIFICATIONS CHAPTER.

**See also**

[Piston rings](#)

## Removing the piston

- Fit the piston and pin onto the connecting rod, aligning the piston arrow towards the engine direction of rotation.

### CAUTION



AT EVERY NEW MOUNTING USE RETAINER RING PINS.

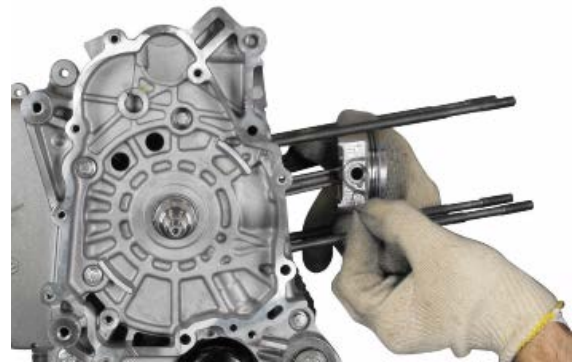

## Choosing the gasket

- Provisionally fit the piston into the cylinder, without any base gasket.
- Assemble a dial gauge on the specific tool.

### Specific tooling

#### 020942Y Piston protrusion check tool

- Using an abutment plane, reset the dial gauge with a pre-load of a few millimetres.
- Finally fix the dial gauge.
- Check the perfect sliding of the feeler pin.
- Install the tool on the cylinder without changing the dial gauge position.
- Lock the tool using the original head fixing nuts.
- Turn the crankshaft to TDC (point at which dial gauge reading reverses).



- Measure the deviation from the reset value.



- By means of the table, see the Specifications chapter identify the cylinder base gasket thickness to be used for refitting. Correctly identify the cylinder base gasket thickness to keep the correct compression ratio.
- Remove the special tool and the cylinder.

### See also

[Slot packing system](#)

## Refitting the piston rings

- Pistons (like cylinders) are supplied in 4 categories: A, B, C and D, and must be fitted so that the reference arrow faces the exhaust duct. The letter is found at the centre of the piston.
- Fit the sealing rings with the word TOP or the identification letter facing upwards. In any case, the step must be facing opposite the piston crown.
- Sealing rings are manufactured with a cylinder contact conical cross-section and piston gaps must be offset by  $120^\circ$  in order to obtain a better bedding.
- Lubricate rings with engine oil when fitting them.

### CAUTION

AT EVERY NEW MOUNTING USE RETAINER RING PINS.

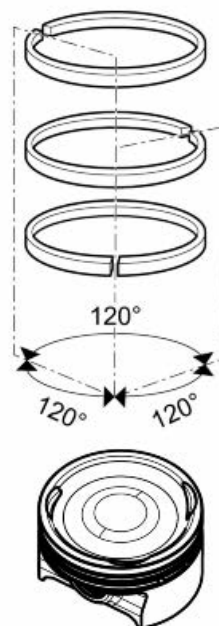

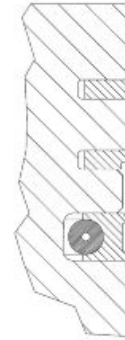

---

## Refitting the cylinder

- Insert the cylinder base gasket with the thickness determined above.
- Using the fork support and the piston ring retaining band, refit the cylinder as shown in the figure.

**N.B.**

**BEFORE FITTING THE CYLINDER, CAREFULLY BLOW OUT THE LUBRICATION DUCT AND OIL THE CYLINDER BARREL.**

### Specific tooling

**020426Y Piston fitting fork**

**020427Y Piston fitting ring**

### Recommended products

**Engine oil 5W -40 Synthetic-based lubricant for four-stroke engines.**

SAE 5W-40; JASO MA, MA2; API SL; ACEA A3



---

## Inspecting the cylinder head

**N.B.**

**TO MEASURE WEAR LIMITS AND COUPLING CLEARANCES, SEE THE SPECIFICATIONS CHAPTER.**

### See also

[Cylinder Head](#)

---

## Inspecting the timing system components

---

- Check that the guide slider and the tensioner slider are not worn out.
- Ensure that the camshaft control pulley chain assembly and the sprocket wheel are not worn.
- If you detect wear, replace the parts or, if the chain, sprocket wheel and pulley are worn, replace the whole unit
- Remove the centre screw with the washer and the tensioner spring. Check that the one-way mechanism is not worn.
- Check the condition of the tensioner spring.
- If examples of wear are found, replace the whole unit.

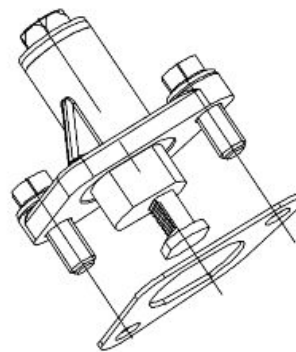
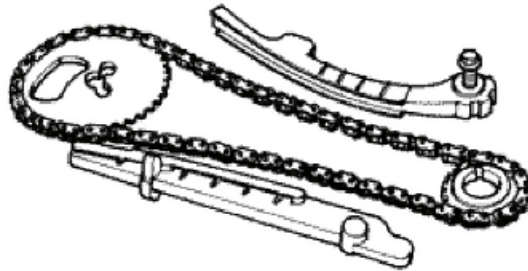

---

## Inspecting the valve sealings

N.B.

TO MEASURE WEAR LIMITS AND COUPLING CLEARANCES, SEE THE SPECIFICATIONS CHAPTER.

See also

[Cylinder Head](#)

---

## Inspecting the valves

N.B.

TO MEASURE WEAR LIMITS AND COUPLING CLEARANCES, SEE THE SPECIFICATIONS CHAPTER.

See also

[Cylinder Head](#)

---

**VALVE CLEARANCE CHECK**

- Remove the cover.
- Position the engine to the TDC in compression.



- Using a feeler gauge check the valve clearance.

**CAUTION**

- USE THE FEELER GAUGE Laterally, IN LINE WITH THE VALVES, IN ORDER TO PREVENT ACCIDENTAL BENDING OF THE BLADE THAT MAY AFFECT THE MEASUREMENTS.

**Characteristic****Valve clearance (cold engine)**

intake: 0.08 mm outlet: 0.08 mm

**Inspecting the springs and half-cones**

- Check that the upper and lower supporting spring washers, the cotters and the oil seal show exhibit no signs of abnormal wear. Replace a component when worn.

**N.B.**

**TO MEASURE WEAR LIMITS AND COUPLING CLEARANCES, SEE THE SPECIFICATIONS CHAPTER.**

**See also**

## Cylinder Head

## Refitting the valves

## CAUTION



MOUNT THE VALVE SPRINGS WITH THE GREEN COLOURED COIL FACING UPWARD.

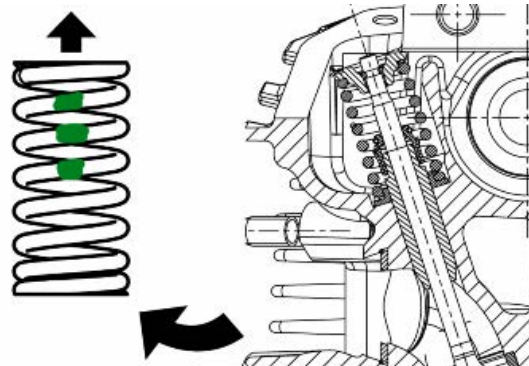

- Lubricate the valve guides with engine oil.
- Place the valve spring supports on the head.
- Using the special punch, fit the three valve seal rings alternately.
- Fit the valves, the springs and the caps. Using the appropriate tool with adapter, compress the springs and insert the cotters in their seats.

## N.B.

DO NOT CHANGE THE VALVE FITTING POSITION. FIT THE VALVE SPRINGS WITH THE REFERENCE COLOUR ON COTTER SIDE (TURNS WITH GREATER PITCH).

## Specific tooling

020382Y Valve fitting/ removal tool

020431Y Valve oil seal extractor





---

## Inspecting the cam shaft

N.B.

TO MEASURE WEAR LIMITS AND COUPLING CLEARANCES, SEE THE SPECIFICATIONS CHAPTER.

See also

[Cylinder Head](#)

---

## Refitting the head and timing system components

- Position the crankshaft to the TDC in compression.



- 
- Insert the head gasket and check the correct operation of the alignment dowels.
  - Insert the chain guide slider.
  - Insert the head.
  - Lubricate the stud bolt threads with engine oil.

- Tighten the nuts to an initial pre-torque of 9-11 Nm.
- Tighten up the nuts by rotating  $270.0 \pm 5.0^\circ$  with crossed sequence.
- Fit the two screws on the outside of the timing chain side and tighten them to the specified torque.

**CAUTION**

DO NOT PERFORM  $270^\circ$  IN ONE ROTATION. PERFORM WITH THREE GRADUAL ROTATIONS, OBSERVING THE SEQUENCE INDICATED ON THE STUD BOLTS.

**N.B.**

BEFORE INSTALLING THE HEAD, MAKE SURE THAT THE LUBRICATION CHANNEL IS CLEAN USING A COMPRESSED AIR JET.

**CAUTION**

ALWAYS USE A NEW HEAD GASKET UPON REFITTING.

**Locking torques (N\*m)**

**Cylinder head nut (TIGHTENING)** 9 - 11 (Tighten to the prescribed torque and then proceed with  $270.0^\circ \pm 5.0^\circ$  rotation) **Screws fixing cylinder to crankcase** 10.8 - 12.7

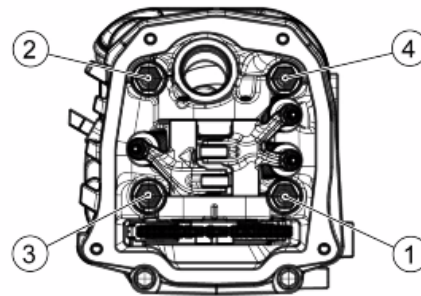
**Refitting the rocker-arms cover**

- Remove the cylinder head cover and tighten the four clamping screws to the prescribed torque.
- Pay attention to the integrity of rubber gaskets, replace them if necessary.
- Make sure the gasket is positioned properly.

**Locking torques (N\*m)**

**Head cover screws** 10.8 - 12.7

**Refitting the intake manifold**

- Follow the disassembly process in reverse order to refit.

## Locking torques (N\*m)

Intake manifold fixing screws 10.8 - 12.8

## Crankcase - crankshaft

### Splitting the crankcase halves

- Undo the eight crankcase coupling screws.
- Separate the crankcase halves while keeping the crankshaft in one of these two halves.
- Only after the halves have been separated, can the crankshaft be checked.

#### CAUTION

WHILE OPENING THE CRANKCASES AND REMOVING THE CRANKSHAFT, CHECK THAT THE THREADED SHAFT ENDS DO NOT INTERFERE WITH THE MAIN BUSHINGS. FAILURE TO OBSERVE THIS PRECAUTION CAN DAMAGE THE MAIN BUSHINGS.

#### CAUTION



KEEP THE CRANKSHAFT IN ONE OF THE TWO HALVES OF THE CRANKCASE WHEN SEPARATING IT. IF YOU FAIL TO DO THIS, THE CRANKSHAFT MIGHT ACCIDENTALLY FALL.

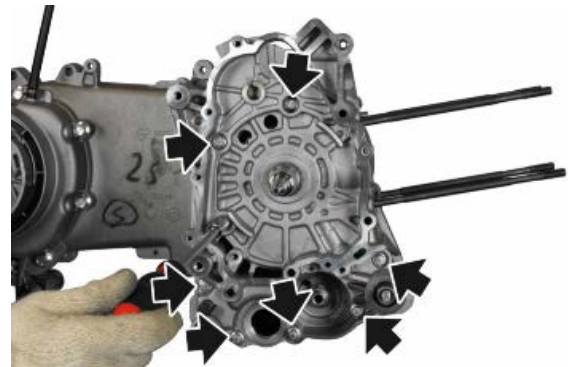

- Remove the gasket and be careful with the alignment dowels.



### Inspecting the crankshaft components

N.B.

TO MEASURE WEAR LIMITS AND COUPLING CLEARANCES, SEE THE SPECIFICATIONS CHAPTER.

#### See also

[Crankcase - crankshaft - connecting rod](#)

## Inspecting the crankshaft alignment

**N.B.**

**TO MEASURE WEAR LIMITS AND COUPLING CLEARANCES, SEE THE SPECIFICATIONS CHAPTER.**

**See also**

[Crankcase - crankshaft - connecting rod](#)

---

## Inspecting the crankcase halves

- Before proceeding to check the crankcase halves, thoroughly clean all surfaces and oil ducts.
- On the transmission-side crankcase half, take particular care when handling the oil pump compartment and the oil ducts, the by-pass duct, the main bushings and the cooling jet on the transmission side.
- Take particular care, also, that there are no signs wear in the oil by-pass valve housing (see Chapter Lubrication), as this could prevent a good seal in the piston, which regulates the oil pressure.
- On the flywheel side crankcase half, take particular care cleaning the oil ducts for the main bushings, the oil duct for the jet that lubricates the cylinder head and the oil drainage duct at the flywheel side oil seal.
- Inspect the coupling surfaces on the crankcase halves for scratches or deformation, taking particular care with the cylinder/crankcase surfaces and the crankcase halves surfaces.
- Defects in the crankcase coupling gasket between the crankcase halves or the mating surfaces shown in the diagram, could cause a drop in the oil pressure lubricating the main bushings and connecting rod.
- Check the main bearing seats that limit axial clearance in the crankshaft show no signs of wear. The dimension between these seats is measured by way of the procedure described previously for measuring the crankshaft axial clearance and dimensions.

**N.B.**

**THE JET IS FED THROUGH THE MAIN BUSHINGS. PROPER OPERATION OF THIS COMPONENT IMPROVES PISTON CROWN COOLING. CLOGGING HAS EFFECTS THAT ARE DIFFICULT TO DETECT (PISTON TEMPERATURE INCREASE). FAILURE OR LEAKS CAN CAUSE A CONSIDERABLE DROP IN THE LUBRICATION PRESSURE FOR MAIN BUSHINGS AND CONNECTING ROD.**

**N.B.**

**THE HEAD LUBRICATION CHANNEL IS PROVIDED WITH A SHUTTER JET;: THIS GIVES A "LOW PRESSURE" HEAD LUBRICATION; THIS CHOICE WAS MADE TO REDUCE THE OIL TEMPERATURE IN THE SUMP. THE JET CLOGGING IMPAIRS THE HEAD LUBRICATION AND THE TIMING MECHANISMS. A JET FAILURE CAUSES A DECREASE OF THE MAIN BUSHING AND CONNECTING ROD LUBRICATION PRESSURE.**

---

## Inspecting the crankshaft plain bearings

- To obtain a good bushing lubrication it is necessary to have both an optimal lubricating pressure (3.2 bar) and a good oil flow rate; the bushings must be correctly positioned so as not to obstruct the oil supply channels.

- The main bushings are comprised of two half-bearings, one with holes and channels for lubrication whereas the other is solid.

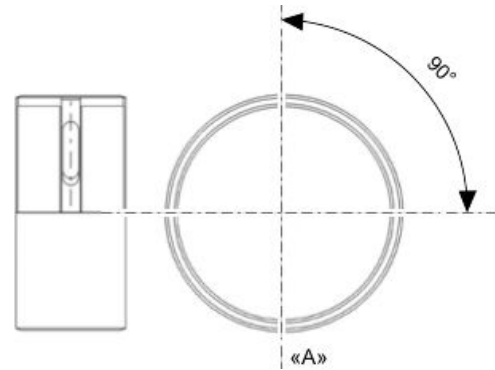

### Characteristic

«A»

AXIS CYLINDER

- The oil feeding channel section is also affected by the bushings driving depth compared with the crankshaft axial clearance of the limiting surface.

N.B.

**TO MEASURE WEAR LIMITS AND COUPLING CLEARANCES, SEE THE SPECIFICATIONS CHAPTER.**

### See also

[Crankcase - crankshaft - connecting rod](#)

## Coupling chart

N.B.

**TO MEASURE WEAR LIMITS AND COUPLING CLEARANCES, SEE THE SPECIFICATIONS CHAPTER.**

### See also

[Crankcase - crankshaft - connecting rod](#)

## Refitting the crankcase halves

- Follow the removal steps but in reverse order; be careful to respect the prescribed tightening torques.

- Insert the by-pass.

- Insert a new gasket and be careful with the alignment dowels.

- Maintaining the crankshaft inserted in the fly-wheel side crankcase, couple the crankcase halves.

- Insert the screws and tighten to specified torque.



**CAUTION**

CAREFULLY CHECK THE CLEANING OF THE BY-PASS DUCT.  
CHECK THAT THE PISTON SLIDES BY HAND, FREELY AND WITHOUT STICKING.

**CAUTION**

IT IS ADVISABLE TO INSERT THE CRANKSHAFT IN THE FLYWHEEL SIDE CRANKCASE HALF TO PREVENT, WITH ACCIDENTAL MOVEMENTS DURING INSERTION, THE OIL PUMP CONTROL TOOTHING FROM DAMAGING THE BUSHINGS.

**Locking torques (N\*m)**

Engine-crankcase coupling screws 11 to 13



- Complete the coupling operations with the verification of the crankshaft axial clearance.
- Using specific tools to support the dial gauge, verify that the fitting clearance is within the limits.
- Higher clearances are signs of wear of the crankshaft - crankcase supporting surfaces.

**Characteristic****Crankshaft-crankcase axial clearance**

0.2 - 0.5 mm

**Studs**

- Using two nuts, fitted as nut and lock nut type, remove and then drive from the seat.
- Proceed with a thorough cleaning of the threaded seat on the crankcase.
- Screw the new stud bolts up to the driving depth indicated.

**N.B.**

NEW STUD BOLTS DO NOT NEED THREADLOCK, AS THEY COME EQUIPPED WITH SCOTCH-GRIP.

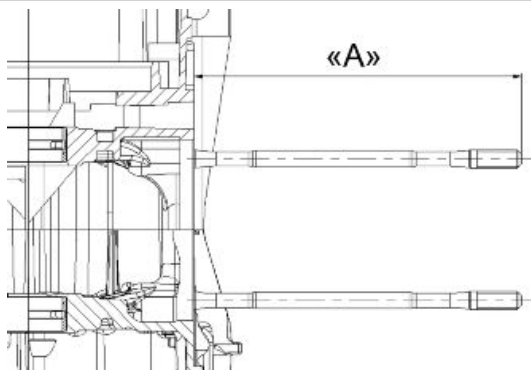
**Characteristic****Driving depth of stud bolts «A»**

170 mm+ 0.5

---

## Lubrication

---

### Conceptual diagrams

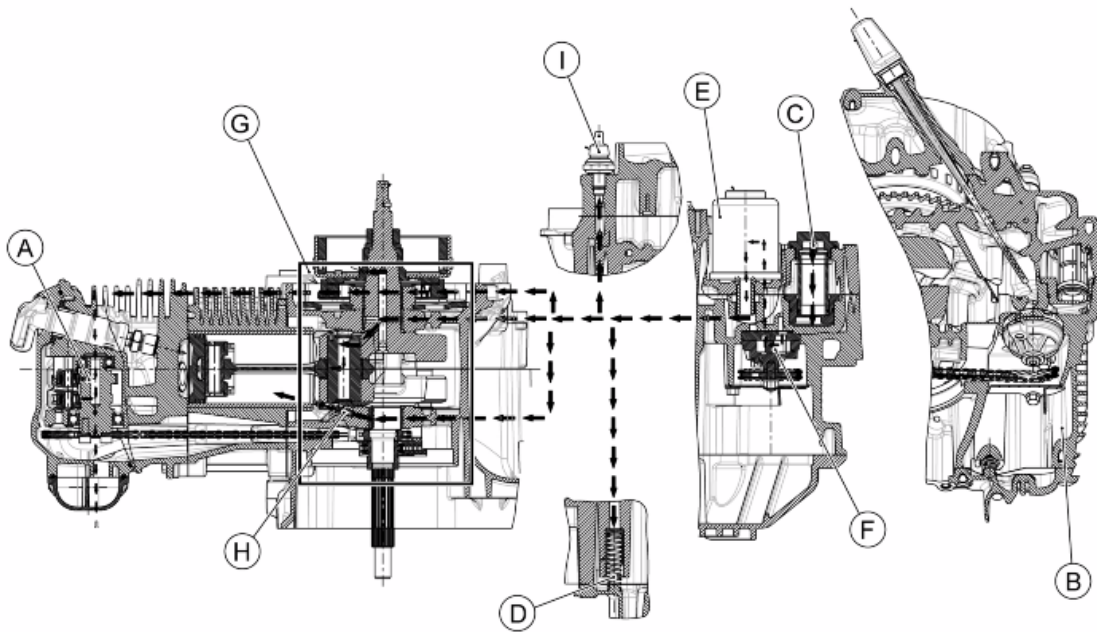

The lobe pump «F» sucks the oil from the sump, through the mesh pre-filter «C», it pushes it into the cartridge filter «E» where there is also a safety valve «D».

Through the suitable passages found in the crankcases, the oil enters the crank chamber «G» where the main bearings are lubricated and the big end (with high pressure), the piston pin and connecting rod small end via spray «H».

Subsequently the oil arrives at the timing system where it lubricates the camshaft «A» and from this, valves and rockers. The oil passes through the timing chain duct and returns to the sump «B» by gravity. In the system there is a minimal oil pressure sensor «I» and a spray that serves to lubricate the stator «L».

---

## Oil pressure check

- After removing the flywheel cover as described in the "Flywheel" chapter, remove the electric connexion of the minimum oil pressure switch and then remove the switch.
- With the engine idling at 1,750 rpm and the oil temperature at  $\sim 90^{\circ}\text{C}$ , check that the oil pressure is between 0.5 - 1.2 atm.
- With the engine idling at 5,000 rpm and the oil temperature at  $\sim 90^{\circ}\text{C}$ , check that the oil pressure is between 3.2 - 4.2 atm.
- Remove the appropriate tools once the measurement is complete, refit the oil pressure switch and washer, tightening it to the specified torque and fit the flywheel cover.
- If the oil pressure is not within the specified limits, in the following order, check: the oil filter, the oil by-pass valve, the oil pump and the crankshaft seals.

**N.B.**

THE CHECK MUST BE CARRIED OUT WITH OIL AT THE CORRECT LEVEL AND WITH AN OIL FILTER IN PROPER CONDITION.

**Characteristic****Oil pressure**

Operating pressure

- At 1,750 rpm: (0.5 - 1.2)bar
- At 5,000 rpm: (3.2 - 4.2)bar

**Locking torques (N\*m)**

Minimum oil pressure sensor 12 - 14

---

## Crankshaft oil seals

---

---

---

## Removal

- Unscrew the three screws and remove them, complete with the copper gaskets.



- Using pliers remove the door by acting on the appendices.



- Remove the spacer and the O-ring.

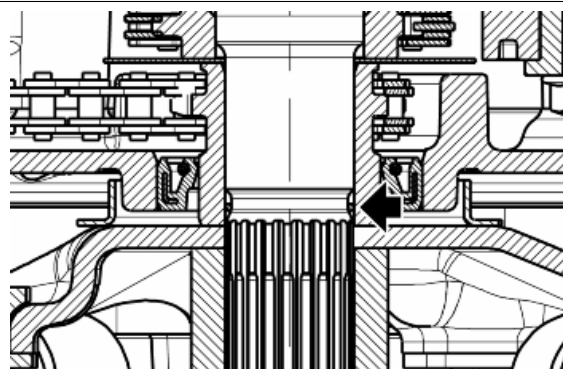

## Refitting

- Insert the components making sure to thoroughly grease the O-ring and the oil seal.
- Follow the steps in reverse order taking care to tighten to torque.

**WARNING**

IN ORDER TO PREVENT ABNORMAL FORMATIONS OF DIRT DUE TO THE RELEASE OF GREASE, WE RECOMMEND FIRST LUBRICATING THE SEAL RING STOPS WITH A BRUSH.

**Locking torques (N\*m)**

Crankcase timing cover screws 11 to 13

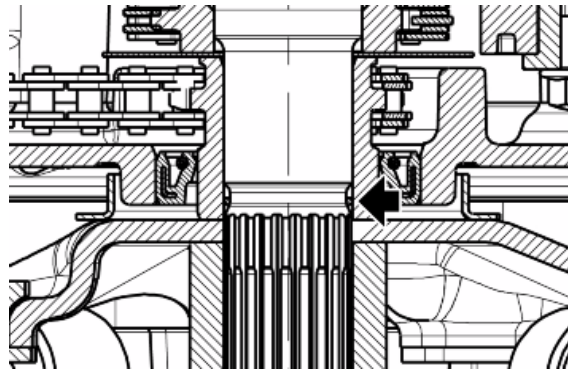

## Oil pump

## Removal

- Remove the oil sump and the by-pass.
- Remove the oil shield.
- Preventing rotation, unscrew the water pump command screw and collect the washer.



- Remove the oil pump command sprocket complete with chain.



- Unscrew the two screws and remove the oil pump.



## Inspection

- Remove the two screws and remove the oil pump cover.
- Remove and wash the rotors thoroughly with petrol and compressed air.
- Reassemble the rotors in the pump body, keeping the two reference marks visible.
- Using a feeler gauge, check the distance between the rotors in the position shown in the figure.
- Check the distance between the outer rotor and pump body, see figure.

Check the axial clearance of the rotors using a tried bar as shown in the figure.

### Characteristic

#### Axial rotor clearance

Limit value admitted: 0.09 mm

#### Distance between the outer rotor and the pump body

Admissible limit clearance: 0.20 mm

#### Distance between the rotors

Admissible limit clearance: 0.12 mm

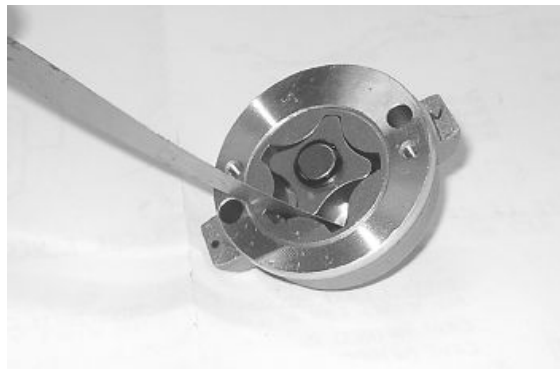



## Refitting

- Follow the steps in reverse order to the removal, tightening the screws to the specified torque.
- Insert the oil pump.
- Insert the control sprocket and the chain.

### N.B.

FIT THE BELLEVILLE WASHER SO THAT ITS OUTER RIM TOUCHES THE PULLEY. MAKE SURE THAT THE PUMP TURNS FREELY.

### Recommended products

Loctite 243 Medium strength thread-locking sealant.

Blue

### Locking torques (N\*m)

Screws fixing oil pump to the crankcase 5 to 6

- Preventing rotation, tighten the water pump command screw complete with washer.

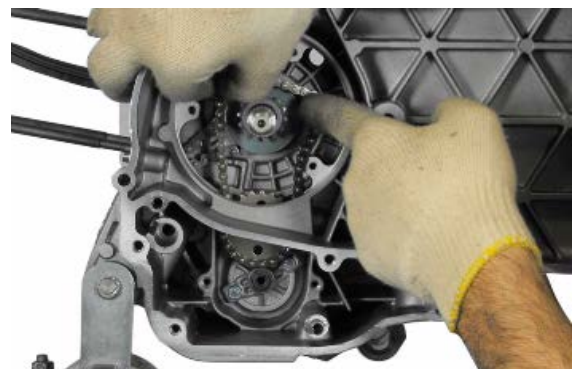



## Removing the oil sump

- Remove the oil filler plug, the transmission cover, the complete drive pulley assembly with belt and the sprocket wheel, as described in the Transmission chapter.
- Drain the oil as described above.
- Remove the seven screws indicated in the figure with the two rear brake transmission retainer brackets.
- Remove the washers, the spring and the by-pass piston.



## Inspecting the by-pass valve

- Check the unloaded spring length.
- Check that the small piston is not scored.
- Ensure that it slides freely on the crankcase and that it guarantees a good seal.
- If not, eliminate any impurities or replace defective parts.



### Characteristic

#### Standard length

52.4 mm

#### Piston standard diameter

12.861 + 12.843 mm

## Refitting the oil sump

- Refit the by-pass piston in its housing.
- Insert the pressure-regulating spring.
- Fit a new sump seal.
- Refit the sump, taking care to locate the spring in the appropriate recess machined into the inside of the sump.
- Refit the rear brake transmission mounting brackets and the screws in the reverse order from which they were removed.
- Tighten the screws to the prescribed torque.
- Refit the driving pulley assembly, the drive belt, the sprocket wheel and the transmission cover, as described in the "Transmission" chapter.
- **When testing the lubrication system, refer to the "Crankcase and Crankshaft" chapter, regarding lubrication of the connecting rod assembly**

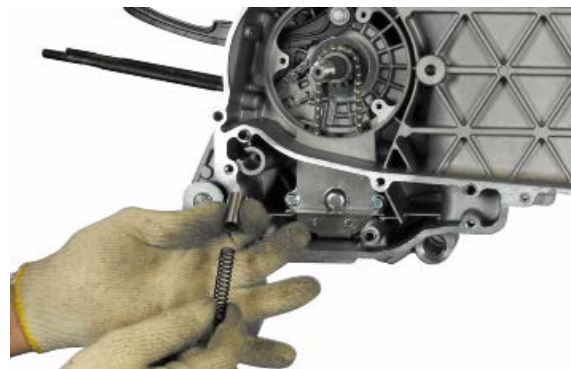

### Locking torques (N\*m)

Tightening torque 11 to 13

## INDEX OF TOPICS

INJECTION

INIEZ

---

## Precautions

### Troubleshooting tips

1 An injection system failure is more likely to be due to the connections than to the components.

Before troubleshooting the injection system, carry out the following checks:

**A: Power supply**

- a. Battery voltage
- b. Blown fuse
- c. Relays
- d. Connectors

**B: Frame ground connection**

**C: Fuel system**

- a. Faulty fuel pump
- b. Dirty fuel filter

**D: Ignition system**

- a. Faulty spark plug
- b. Faulty coil
- c. Faulty shielded cap

**E: Intake circuit**

- a. Air filter dirty
- b. Dirty by-pass circuit
- c. Idle speed adjustment device

**F: Others**

- a. Wrong timing system
- b. Wrong idle mixture
- c. Incorrect reset of the throttle valve position sensor

2 Injection system failure may be caused by loose connectors. Make sure that all connections have been correctly made.

Check the connectors taking into consideration the following point:

**A** check that the terminals are not bent.

**B** check that the connectors have been properly connected.

**C** - Check whether the malfunction can be fixed by shaking the connector slightly.

3 Check the entire system before replacing the injection control unit. If the fault is fixed even by replacing the control unit, install the original control unit again and check if the fault occurs again.

4 For troubleshooting, use a multimeter with an internal resistance of more than 10 KW/V. Improper instruments may damage the injection control unit. The instruments to be preferred have a definition over 0.1V and 0.5W and an accuracy over 2%.

1. Before repairing any part of the injection system, check if any faults have been stored. Do not disconnect the battery before checking for faults.
  2. The supply system is pressurised at 250 kPa (2.5 BAR). Before disconnecting the fast-release fitting of the fuel supply pipe, check that there are no naked flames. Do not smoke. Act with caution to avoid spraying fuel to your eyes.
  3. When repairing electric components, the battery must always be disconnected unless it is strictly necessary for the battery to be connected.
  4. When functional checks are performed, make sure that the battery voltage exceeds 12V.
  5. Before attempting to start the vehicle, ensure that there are at least two litres of fuel in the tank. Failure to respect this norm will damage the fuel pump.
  6. If a long period is envisaged with the vehicle not in use, fill the tank to at least the halfway mark. This will ensure the pump will be covered by fuel.
  7. When washing the vehicle, do not spray excessive water on electric components and wiring harnesses.
  8. In the event of ignition problems, begin troubleshooting from the battery and the injection system connections.
  9. Before disconnecting the connector of the injection control unit, perform the following steps in the order shown:
    - Set the switch to «OFF»
    - Disconnect the batteryFailure to respect this norm may damage the control unit.
  10. Do not invert the poles when fitting the battery.
  11. To avoid causing any damage, disconnect and reconnect the injection system connectors only if required. Before reconnecting, check that the connectors are dry.
  12. When carrying out electric inspections, do not force the tester probes into the connectors. Do not take measurements not specifically foreseen by the manual.
  13. At the end of every check performed with the diagnostic tester, remember to protect the system connector with its cap. Failure to observe this precaution may damage the injection control unit.
  14. Before reconnecting the quick couplers of the power supply system, check that the terminals are perfectly clean.
-

## Terminals setup

### CDI

1. Ve - fuel pump
2. MaBi - injection warning light
3. AzRs - lambda heater
4. Gi - Immobilizer LED
5. RsBi - + Batt
6. RsGi - injector
7. GrVe - Sensor ground
8. RoNe - H.V. coil
9. NeVe - Injection loads
10. ArNe - K Line
11. VeBi - Start enable
12. Rs - Pick-up
13. VeBL - Lambda probe
14. ArBi - Throttle position sensor
15. Ar - Tip over sensor
16. AzVe - Engine temperature sensor
17. BiNe - Engine idle adjustment valve
18. RsNE - Sensor power supply
19. Ne - Ground
20. ArVe - Key powered

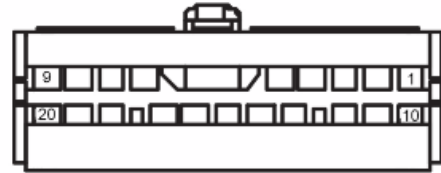

## Troubleshooting procedure

### Engine does not start

#### **ENGINE DOES NOT START EVEN IF PULLED**

Possible Cause	Operation
Immobilizer enabling signal	System not encoded System not efficient, repair according to the indications of the self-diagnosis
Faults detected by self-diagnosis	Pump relay H.V. coil Injector Engine speed timing sensor
Fuel system	Fuel in the tank Fuel pump activation Fuel pressure (low) Injector flow (low)
Power to spark plug	Shielded spark plug cap H.V. coil (secondary insulation)
Parameter reliability	Engine temperature Distribution timing adjustment - injection start Intake air temperature
End of compression pressure	End of compression pressure

## Starting difficulties

### ENGINE STARTER PROBLEMS

Possible Cause	Operation
Faults detected by self-diagnosis	Pump relay H.V. coil Injector Engine speed timing sensor Air temperature Engine temperature
Starter speed	Starter motor and relay Battery Ground connections
End of compression pressure	End of compression pressure
Power to spark plug	Spark plug Shielded cap H.V. coil Engine speed timing sensor Ignition advance
Fuel system	Fuel pressure (low) Injector flow (low) Injector sealing (poor)
Correctness of the parameters	Engine temperature Intake air temperature Stepper throttle valve position (steps and actual opening) Cleaning the throttle valve, air filter efficiency

## Engine stops at idle

### ENGINE DOES NOT IDLE/ IDLING IS UNSTABLE/ IDLING TOO LOW

Possible Cause	Operation
Faults detected by self-diagnosis	Pump relay H.V. coil Injector Engine speed timing sensor Air temperature Engine temperature
Ignition efficiency	Spark plug Ignition timing
Correctness of the parameters	Throttle valve position sensor Stepper Engine temperature sensor Intake air temperature sensor
Intake system cleaning	Air filter Diffuser and throttle valve Stepper
Intake system sealing (infiltrations)	Intake manifold - head Throttle body - manifold Air cleaner joint Filter housing
Fuel system (low pressure)	Fuel pump Pressure regulator Fuel filter Injector flow

## Engine does not rev down

### ENGINE DOES NOT RETURN TO IDLING SPEED/IDLING SPEED TOO HIGH

Possible Cause	Operation
Faults detected by self-diagnosis	Pump relay

Possible Cause	Operation
	H.V. coil Injector Engine speed timing sensor Air temperature Engine temperature
Ignition efficiency	Ignition timing
Correctness of the parameters	Throttle valve position sensor Stepper Engine temperature sensor Intake air temperature sensor
Intake system sealing (infiltrations)	Intake manifold - head Throttle body - manifold Air cleaner joint Filter housing
Fuel system (low pressure)	Fuel pump Pressure regulator Fuel filter Injector flow

### Exhaust backfires in deceleration

#### **EXHAUST BACKFIRING WHEN DECELERATING**

Possible Cause	Operation
Faults detected by self-diagnosis	Pump relay H.V. coil Injector Engine speed timing sensor Air temperature Engine temperature Lambda probe
Correctness of the parameters	Throttle valve position sensor Stepper Engine temperature sensor Intake air temperature sensor
Intake system sealing (infiltrations)	Intake manifold - head Throttle body - manifold Air cleaner joint Filter housing
Fuel system (low pressure)	Fuel pump Pressure regulator Fuel filter Injector flow
Exhaust system sealing (infiltrations)	Manifold - head Manifold - silencer silencer welding

### Engine revs irregularly

#### **ENGINE IRREGULAR PERFORMANCE WITH VALVE SLIGHTLY OPEN**

Possible Cause	Operation
Intake system cleaning	Air filter Diffuser and throttle valve Stepper
Intake system sealing	Air cleaner joint Filter housing
Ignition system	Spark plug wear check
Parameter reliability	Throttle valve position signal Engine temperature signal Intake air temperature signal Ignition advance
TPS reset successful	TPS reset successful
Faults detected by self-diagnosis	Pump relay H.V. coil

**Possible Cause**

**Operation**

Injector  
 Engine speed timing sensor  
 Air temperature  
 Engine temperature  
 Lambda probe

**Poor performance at full throttle**

**POOR ENGINE PERFORMANCE AT FULL POWER/ ENGINE IRREGULAR PERFORMANCE ON PICK-UP**

**Possible Cause**

**Operation**

Faults detected by self-diagnosis

Pump relay  
 H.V. coil  
 Injector  
 Engine speed timing sensor  
 Air temperature  
 Engine temperature  
 Lambda probe

Power to spark plug

Spark plug  
 Shielded cap  
 H.V. cable  
 H.V. coil

Intake system

Air filter  
 Filter box (sealing)  
 Air cleaner joint (sealing)

Parameter reliability

Throttle valve position signal  
 Engine temperature signal  
 Intake air temperature signal  
 Ignition advance

Fuel system

Fuel level in the tank  
 Fuel pressure  
 Fuel filter  
 Injector flow

**Engine knocking**

**PRESENCE OF KNOCKING (COMBUSTION SHOCKS)**

**Possible Cause**

**Operation**

Faults detected by self-diagnosis

Pump relay  
 H.V. coil  
 Injector  
 Engine speed timing sensor  
 Air temperature  
 Engine temperature  
 Lambda probe

Ignition efficiency

Spark plug

Parameter reliability

Throttle valve position signal  
 Engine temperature signal  
 Intake air temperature signal  
 Ignition advance

Intake system sealing

Air cleaner joint  
 Filter housing

TPS reset successful

TPS reset successful

Fuel system

Fuel pressure  
 Fuel filter  
 Injector flow  
 Fuel quality

Selection of the cylinder base gasket thickness

Selection of the cylinder base gasket thickness

## Fuel supply system

The fuel system circuit includes the electric pump, the filter, the pressure regulator, the electro-injector and the fuel delivery pipes.

The electrical pump is located in the tank from which the fuel is pumped and sent to the injector through the filter.

The pressure is controlled by the pressure regulator situated in the pump assembly in the tank.

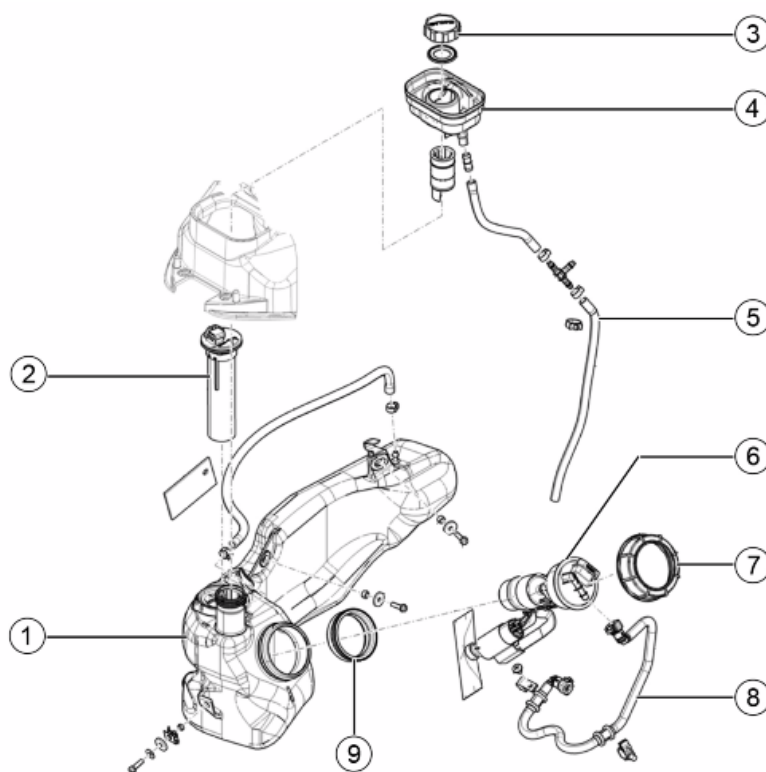
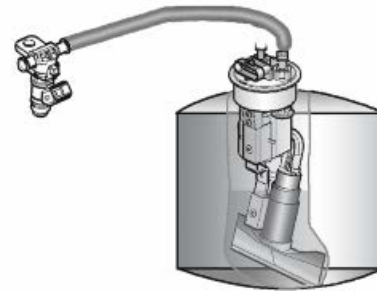

### Key:

1. Fuel tank
2. Fuel gauge
3. Fuel tank cap
4. Fuel filler spill tray
5. Complete vent pipe
6. Complete fuel pump
7. Fuel ring
8. Fuel delivery pipe
9. Fuel pump gasket

**REMOVING THE COMPLETE FUEL PUMP**

Remove the helmet compartment.

Disconnect the battery cables in order to carry out the work safely.



remove the fuel tank filler cap to release the pressure in the tank.



Disconnect the fuel pump electrical connector.



Disconnect the coupling between the fuel pipe and the pump.

Wrap the end of the fuel pipe in a cloth to prevent fuel from escaping.

Refit and tighten fuel tank filler cap.

**CAUTION**

**FUEL IS HIGHLY FLAMMABLE. DO NOT SMOKE AND KEEP ALL NAKED FLAME AND SOURCES OF SPARKING OUT OF THE AREA: FIRE HAZARD. DO NOT INHALE THE FUEL SMOKE. DO NOT ALLOW FUEL TO COME INTO CONTACT WITH PLASTIC COMPONENTS OR THE BODY-WORK OF THE VEHICLE.**



Unscrew the fastener ring of the fuel pump, turning it anticlockwise.



Mark the correct orientation of the fuel pump relative to its seat on the tank with a marker pen.



**NOTE:**

Apply the marking on the fuel pump and the relative seat as shown in the figure.

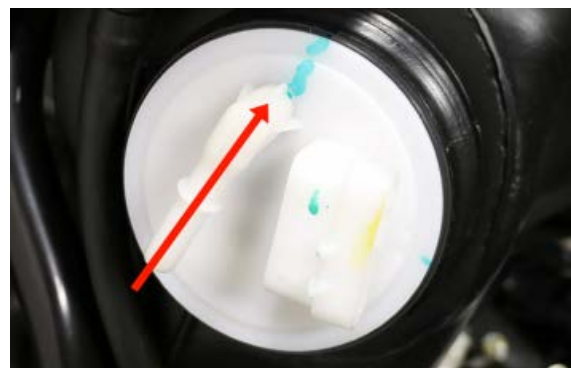

Disengage the gasket from the tank and remove the complete fuel pump, turning it towards the side of the tank.



**FITTING THE COMPLETE FUEL PUMP**

Insert the new gasket on the fuel pump body and place it temporarily in the appropriate upper seat of the fuel pump.



Apply the assembly marking to new fuel pump as shown in the figure.

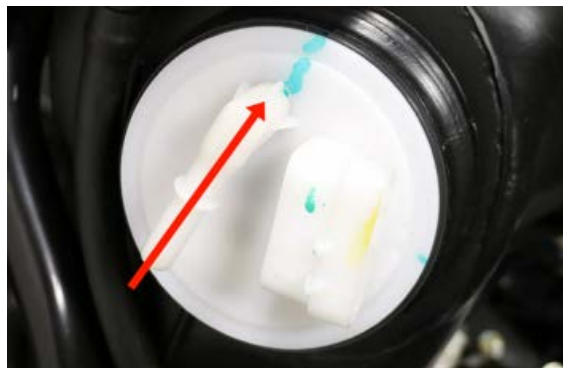

Place the complete fuel pump inside the tank.



Fit the gasket, pushing downwards to ensure that it is flush with the surface of the tank.



Push the fuel pump downwards to bring it against the gasket.



**NOTE:**

Ensure that the fuel pump is oriented correctly by aligning the markings made previously on the pump and on the relative seat.



Fit the fastener ring of the fuel pump.

Tighten the fastener ring of the fuel pump firmly, turning clockwise.

**WARNING**



**MAKE SURE THAT THE FASTENER RING IS TIGHTENED COMPLETELY.**



Connect the coupling between the fuel pipe and the pump.



Connect the electrical connector on the fuel pump.



Mount the helmet compartment.  
Carefully tighten all fixing screws and connect the battery cables.



#### REMOVING THE COMPLETE FUEL SENSOR

To replace the fuel level sensor, follow the procedure described below.

Remove the helmet compartment.

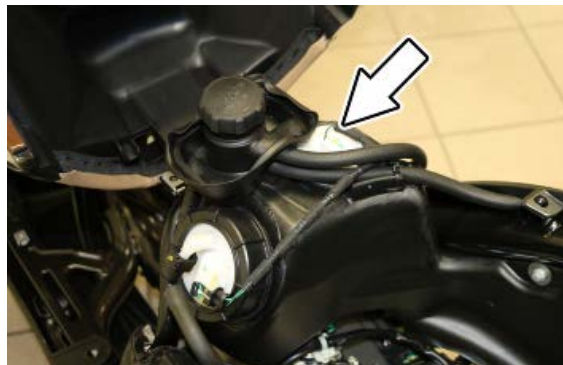

Disconnect the electrical connector from the fuel level sensor.

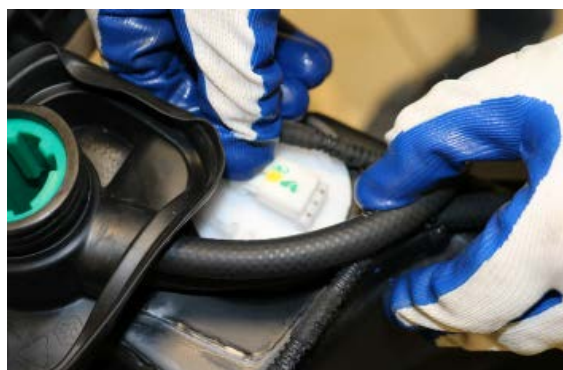

Unscrew the fuel level sensor, turning anticlockwise; use the specific tool included with the vehicle if necessary.

### Specific tooling

020442Y Pulley lock wrench



Remove the fuel level sensor from the fuel tank.

### CAUTION



**FUEL IS HIGHLY FLAMMABLE. DO NOT SMOKE AND KEEP ALL NAKED FLAME AND SOURCES OF SPARKING OUT OF THE AREA: FIRE HAZARD. DO NOT INHALE THE FUEL SMOKE. DO NOT ALLOW FUEL TO COME INTO CONTACT WITH PLASTIC COMPONENTS OR THE BODYWORK OF THE VEHICLE.**



### FITTING THE COMPLETE FUEL LEVEL SENSOR

Insert the new fuel level sensor complete with gasket inside the tank.

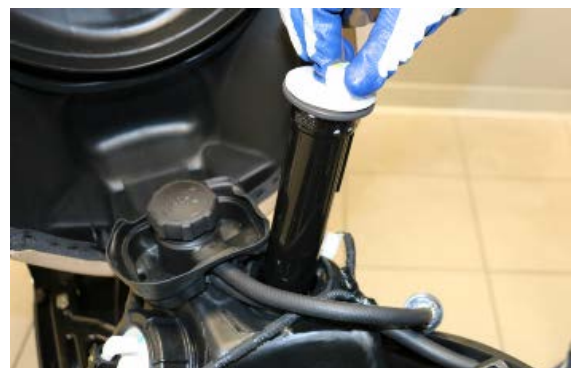

Tighten the fuel level sensor, turning clockwise; use the specific tool included with the vehicle if necessary.

### Specific tooling

020442Y Pulley lock wrench



Connect the electrical connector to the fuel level sensor.

Mount the helmet compartment. Carefully tighten all fixing screws.



## Removing the injector

- Remove the helmet compartment.
- Disconnect the injector connector.



- Remove the injector support bracket wiring harness fastening clamp.

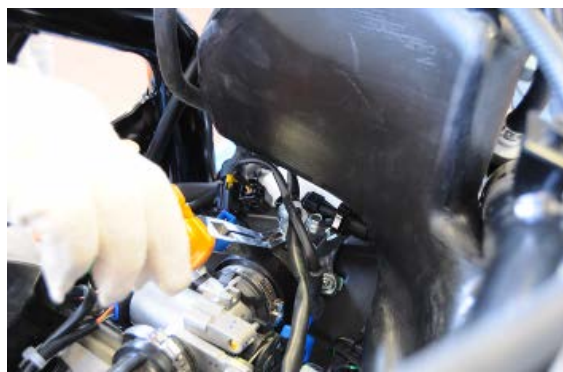

- Loosen the manifold fastening clamp.



- 
- Unscrew and remove the injector to manifold fixing screws.



- 
- Remove the injector.



---

## Refitting the injector

For refitting, perform the removal operations in reverse order and lubricate the sealing OR gasket with grease for internal application before fitting the injector on the manifold.

---

## Removing the butterfly valve

- 
- Remove the throttle grip cables.



- Remove the throttle position sensor connector.



- Remove the idle adjuster pipe.



- Slacken clamp and remove the air intake pipe.



- loosen the clamp and remove the throttle body.



- Clean the throttle body.

**WARNING**

AFTER MAINTENANCE OPERATIONS, IT IS RECOMMENDED TO DELETE THE SELF-ADJUSTABLE PARAMETERS.

**Recommended products**

**Detergent for throttle bodies Spray cleaner for throttle bodies**

Detergent for throttle bodies



## Refitting the butterfly valve

- After refitting, delete the error and reset the adaptive parameters.
- Keep the engine running at idle speed for 15 minutes.

Do not tamper with the stop screw under the throttle body.

**CAUTION**

DO NOT TAMPER WITH THE STOP SCREWS UNDER THE THROTTLE BODY, AS THE IDLE SPEED IS ADJUSTED IN THE FACTORY.



## Pump supply circuit

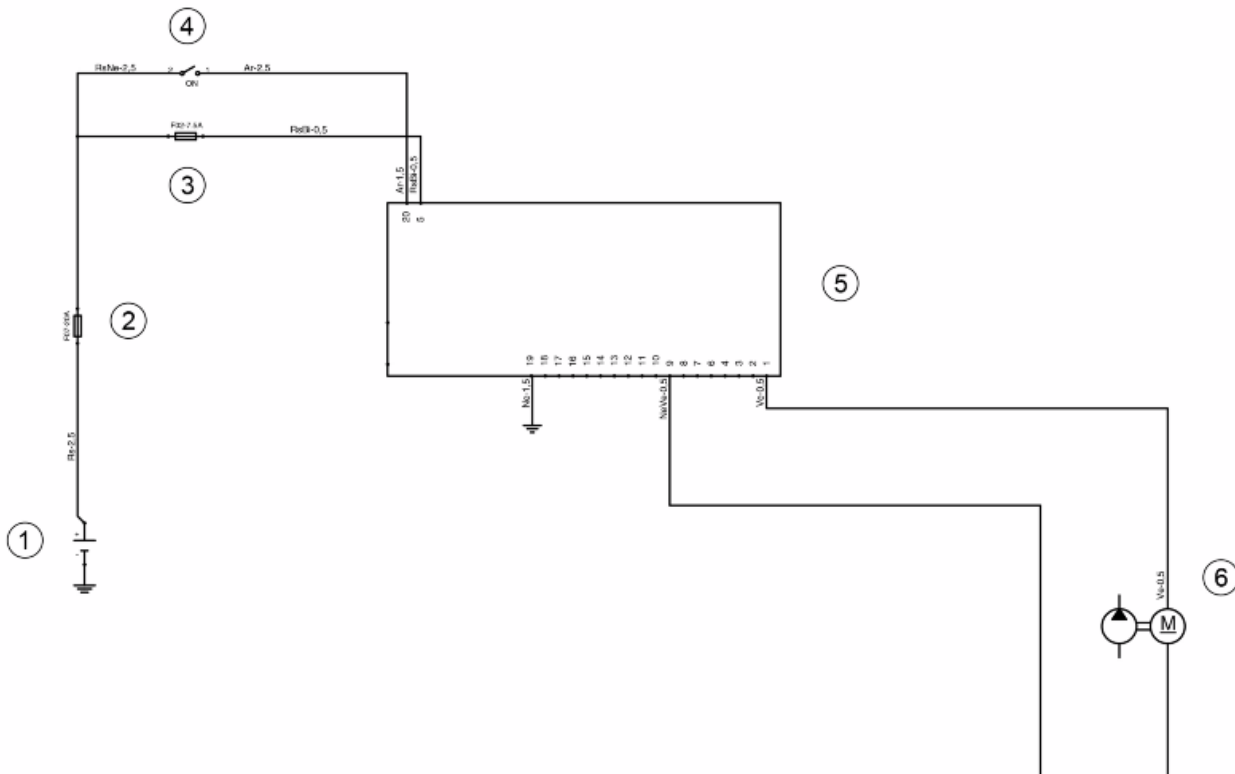

### KEY

1. Battery
2. Fuse No.01 - 20 A
3. Fuse No.02 - 7.5A
4. Ignition switch
5. Electronic control unit
6. Fuel pump

When switched to "ON", the fuel pump starts to rotate for two seconds and then stops.

When the engine starts, in the presence of rpm timing signal the pump is continuously supplied.

### ELECTRICAL DATA

- Pump winding resistance ~ 1.5 ohm
- Input current during normal functioning 1.4 - 1.8 A.
- input current to the closed hydraulic circuit ~ 2 A (to be checked with specific tool for fuel pressure.)

## Circuit leak test

Install the specific tool for checking the fuel pressure, with the pipe fitted with the gauge.

Check during regular operation by placing the appropriate tool between the pump and the injector. With the battery voltage > 12 V check that the fuel pressure is 2.5 BAR and that the input current is 1.4 - 1.8 A.



With the battery voltage > 12 V, check the pump flow rate by disconnecting from the injector the pipe equipped with the pressure gauge of the appropriate tool. Make a graded burette available with a flow rate of approximately 1 L. Rotate the pump using the active diagnosis of the palm top computer. Using a pair of long flat needle-nose pliers, choke the fuel pipe making the pressure stabilise at approx. 2.5 bar. Check that within 15 seconds the pump has a flow rate of approx. 110 cm<sup>3</sup>.

### Specific tooling

020480Y Fuel pressure measurement kit

## Fuel filter check

After removing from the tank, disconnect the electric pump terminals.

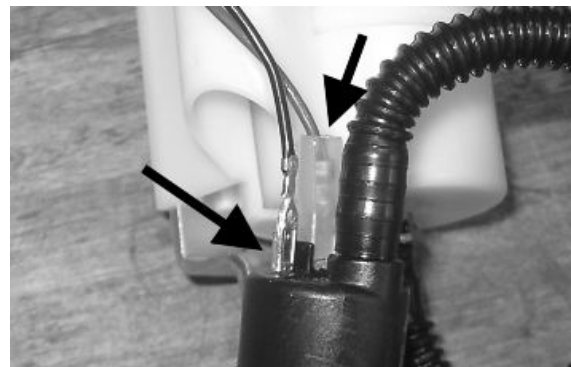

Remove the screw shown in the picture

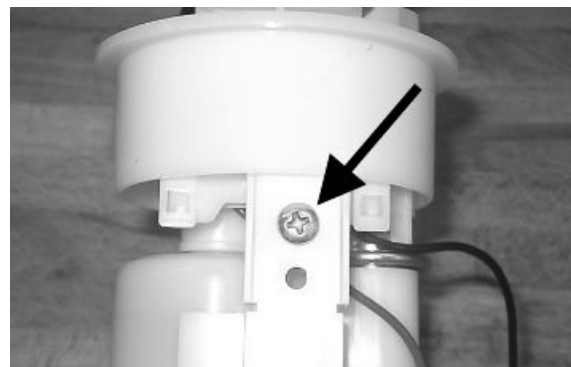

Remove the clamp fixing the piping to the filter shown in the photograph

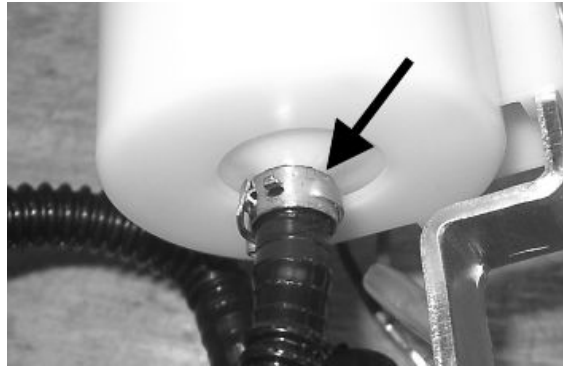

Separate the lower part of the pump mounting as shown in the picture.

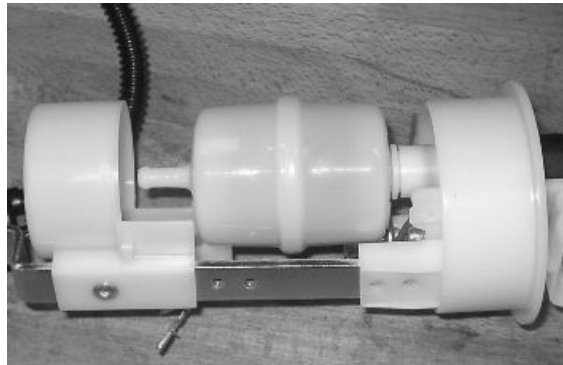

Remove the filter from the pump mounting



## Inspecting the injector hydraulics

- Remove the injector.

Install the specific tool to check the fuel pressure and position the injector on a graduated container of at least 100 cm<sup>3</sup>.

- Connect the clamps of the cable supplied to an auxiliary battery.

- Activate the fuel pump with diagnostics engaged and make sure that within fifteen seconds, approximately 40 cm<sup>3</sup> of fuel is dispensed with a pressure of approximately 2.5 BAR.



**Specific tooling**

**020480Y Fuel pressure measurement kit**

Proceed with the injector seal test.

Dry the injector outlet with a blast of compressed air. Activate the fuel pump. Wait for one minute, making sure there are no leaks coming from the injector. Slight oozing is normal.

Value limit = 1 drop per minute

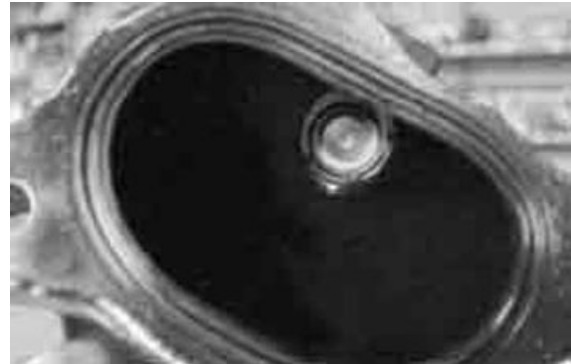

**HT coil**

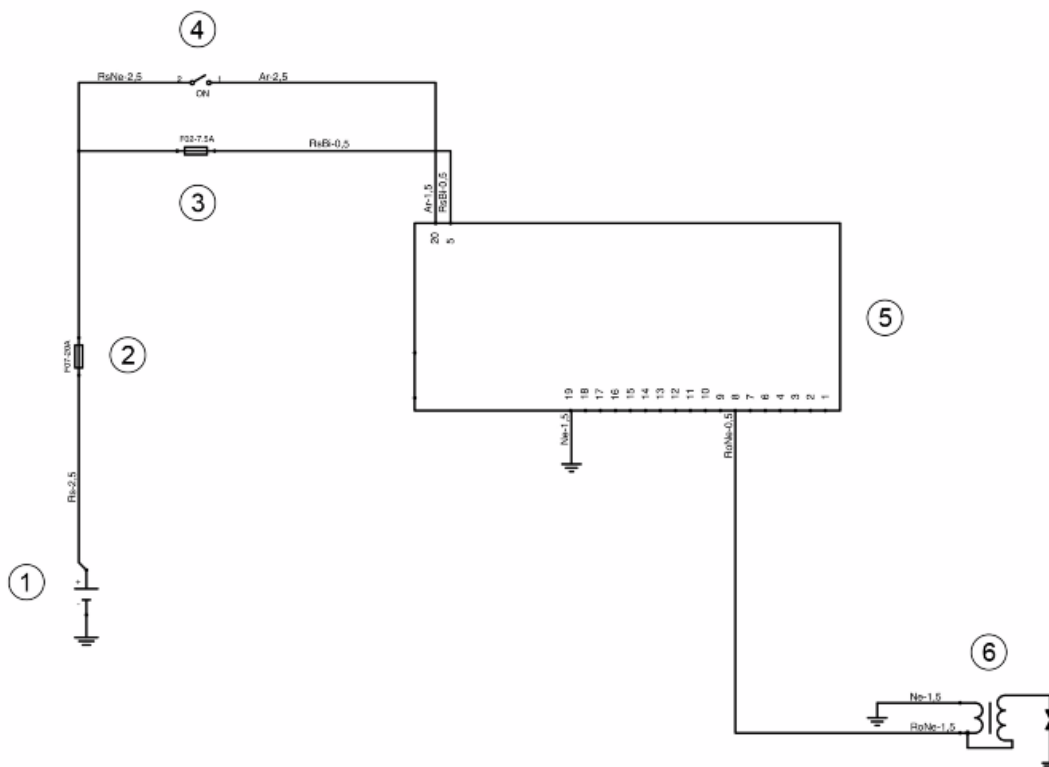

**KEY**

- 1. Battery
- 2. Fuse No.01 - 20 A
- 3. Fuse No.02 - 7.5A
- 4. Ignition switch
- 5. Electronic control unit
- 6. H.V. coil

The system is integrated with the injection and it is a high-efficiency inductive type ignition.

The control unit manages two significant parameters:

- Ignition advance

This is optimised at the moment in accordance with the engine revs, engine load, temperature and environmental pressure.

With the engine at idle, the ignition advance is optimised to stabilise the speed at  $1,450 \pm 50$  rpm.

- Magnetisation time

The coil magnetisation time is controlled by the control unit. The ignition power is increased during the engine start-up phase.

The injection system recognises the 4-stroke cycle so ignition is only commanded in the compression phase.

### **Specific tooling**

**020331Y Digital multimeter**

---

## **Zeroing the throttle**

### **Resetting the throttle valve position signal (T.P.S reset)**

The throttle body is supplied with throttle valve position sensor and is pre-calibrated.

Pre-calibration entails regulating the minimum opening of the throttle valve to obtain a certain flow of air under pre-set reference conditions.

Pre-calibration ensures optimal air flow to control idling.

### **This regulation must not be tampered with in any way whatsoever.**

The injection system will complete the management of the idling through the related device and the variation of the ignition advance.

The throttle body after the pre-calibration has an opened valve with an angle that can vary depending on the tolerances of the machining of the pipe and the valve itself.

The valve position sensor can also assume various fitting positions. For these reasons the mV of the sensor with the valve at idle can vary from one throttle body to another.

To obtain the optimum fuel mixture, especially at small openings of the throttle valve, it is essential to match the throttle body with the control unit following the procedure known as TPS resetting.

With this operation we inform the control unit, as the starting point, of the mV value corresponding to the pre-calibrated position.

To reset, proceed as follows.

Connect the diagnostic tester.

Switch to «**ON**».

Select the functions of the diagnostic tester on «**TPS RESET**».

### **Specific tooling**

**020922Y Diagnosis Tool**

---

Make sure that the throttle valve with the control is supporting the stop screw.



With the throttle completely closed, check that the cables have clearance in all steering positions and confirm the position at the diagnostic tool.

Keep the throttle in a completely open position and confirm the position at the diagnostic tool.

**CAUTION**

**DO NOT TAMPER WITH THE STOP SCREWS UNDER THE THROTTLE BODY, AS THE IDLE SPEED IS ADJUSTED IN THE FACTORY.**

---

# INDEX OF TOPICS

**S**SUSPENSIONS

**SOSP**

---

## Front

---

### Removing the front wheel

- Remove the locking nut of the wheel axle while keeping the wheel axle locked in place.
- Slide off the axle and remove the wheel.

**CAUTION****SUPPORT THE VEHICLE ADEQUATELY.****CAUTION****WHEN REMOVING THE FRONT WHEEL, THE BRAKE CALLIPER AND THE DISC, PAY ATTENTION TO THE TONE WHEEL. THE DAMAGE OF THE TONE WHEEL DOES NOT ALLOW A CORRECT USE OF THE ABS-SYSTEM.**

---

### Front wheel hub overhaul

- Remove the spacer from the left side of the wheel.



- Remove the brake disc.



- Remove the oil guard from the left side of the wheel.



- Using the specific puller, remove the bearing.

**Specific tooling**

**001467Y013 Calliper to extract  $\varnothing$  15-mm bearings**

**001467Y009 Bell for OD 42-mm bearings**



- Remove the oil guard from the right side of the wheel.



- Using the specific puller, remove the bearing.

**Specific tooling**

**001467Y013 Calliper to extract  $\varnothing$  15-mm bearings**

**001467Y009 Bell for OD 42-mm bearings**



Use the specific tools to fit the new bearings.

**Specific tooling**

**020412Y 15-mm guide**

**020375Y 28 x 30 mm adaptor**

**020376Y Adaptor handle**

## Refitting the front wheel

Position the wheel with shims, position the axle and tighten to the specified torque.

### Locking torques (N\*m)

Front wheel axle 44.1 - 49

---

## Handlebar

---

### Removal

- Remove the front cover.
- Remove the rear brake cable.



- Remove the locking U-bolt of the accelerator handlebar.



- Disconnect the stop switch connectors.



- Remove the locking U-bolt of the front brake pump.



- Undo the screw fixing the handlebar to the steering tube.



- Remove the screw fixing the handlebar to the steering tube paying attention to the washers in place.



---

## Refitting

- Work in the inverse order of removal and pay close attention when routing the cables.

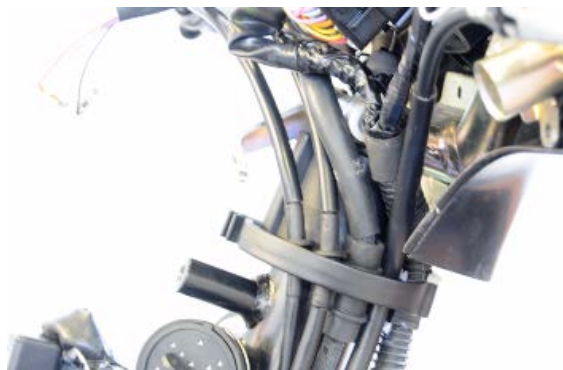

---

## Steering column

---

## Removal

- Remove the handlebar.
- Remove the plastic protection of the steering ring nuts.



Use the specific tool to remove the steering ring nut.

### Specific tooling

**020055Y Wrench for steering tube ring nut**



## Refitting

- Tighten the lower lock ring to the torque specified.
- Tighten the top lock ring to the specified torque while keeping the bottom lock ring in place.

### CAUTION

DO NOT EXCESSIVELY TIGHTEN THE LOWER RING NUT BECAUSE THE STEERING BEARINGS COULD GET DAMAGED.

### Locking torques (N\*m)

**Lower steering ring nut 12 to 14 (8.9 to 10.3 lb\*ft) Upper steering ring nut 35 to 40 (25.8 to 29.5 lb\*ft)**

## Steering bearing

Only remove the seats if it is strictly necessary.

- Using the special tool remove the upper bearing seat by putting the special tool into the lower part of the headstock as indicated in the figure.

### Specific tooling

**020004Y Punch for removing steering bearings from headstock**



- 
- Remove the bottom bearing seat using the specific tool.

**Specific tooling**

**020004Y Punch for removing steering bearings from headstock**

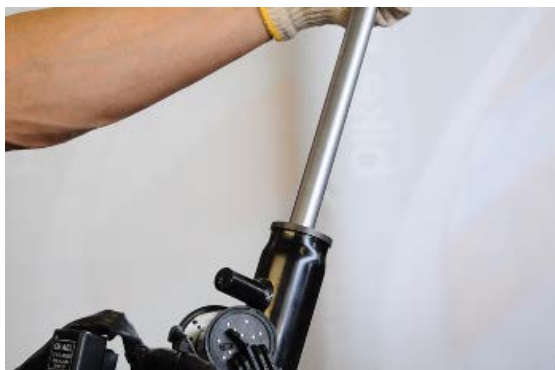

- 
- Remove the bottom bearing seat from the steering pipe.



- 
- Mount the new seats onto the frame using the specific tools.

**Specific tooling**

**001330Y Tool for fitting steering seats**



---

## Rear

---

### Removing the rear wheel

- 
- Remove the silencer.
  - Remove the screws fixing the rear wheel to the hub.



---

- Remove the rear wheel.



---

- Align the split pin.

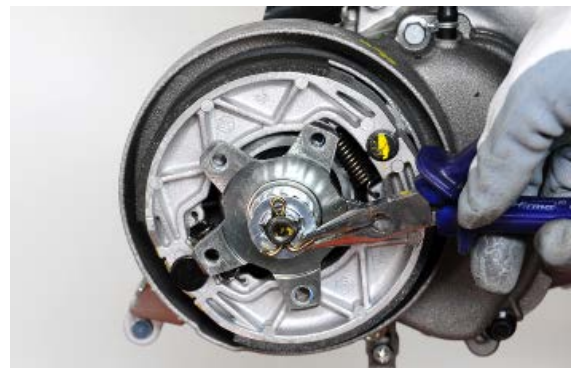

---

- Remove the cotter pin and the plastic cover of the nut.



---

- Unscrew the wheel axle nut.



- Remove the wheel axle nut and its washer.



- Remove the wheel hub.

## Refitting the rear wheel

Carry out the operations in the reverse order, observing the locking torques.

### Locking torques (N\*m)

Rear wheel nut 104 to 126 (76.7 to 92.9 lb\*ft) Rear wheel to hub fixing screws 20 to 25 (14.7 to 18.4 lb\*ft)

#### CAUTION



WHEN FITTING THE SILENCER SUPPORT BRACKET, IT IS NECESSARY TO GREASE THE INSIDE OF THE DUST GAITER AND THE SEALING LIP WITH THE RECOMMENDED PRODUCT AND FILL THE THROAT UNDER THE BEARING.

### Recommended products

#### Calcium based grease Calcium grease

Smooth-textured appearance; Ivory colored Specification TL 9150 066, symbol NATO G 460

### Characteristic

#### Product quantity on inside dust gaiter

~ 1 cm<sup>3</sup>

#### Product quantity on outside dust gaiter

~ 3 cm<sup>3</sup>

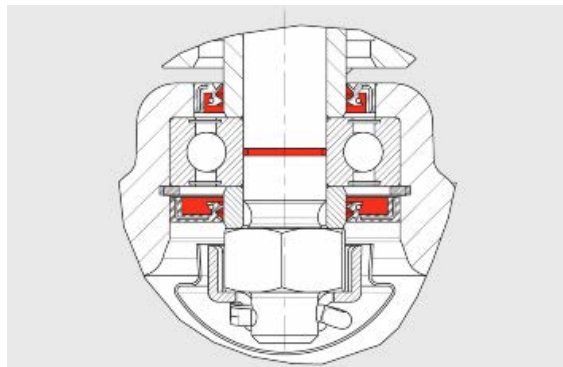

## Swing-arm

## Removal

- Remove the screw securing the swing arm-engine.



- Remove the screw securing the swing arm-frame.



- Remove the fixing screw from the bracket with silent block to the frame.



## Overhaul

- Separate the swinging arm on the engine side from frame side swinging arm.



- 
- Remove the shims and the o-rings from the swinging arm.



- 
- Remove the pin.

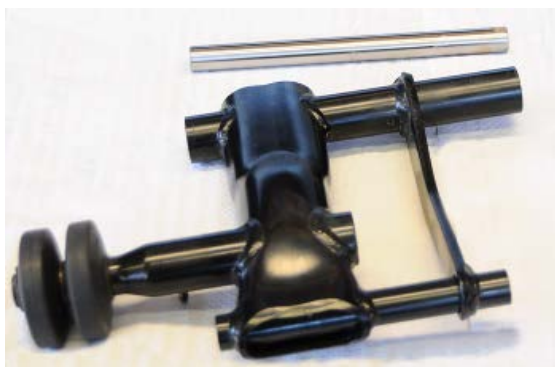

- 
- Remove the oil guard.



- 
- Remove the bearings using the suitable tools.

#### Specific tooling

001467Y034 Calliper to extract  $\varnothing$  15-mm bearings

001467Y010 Driver for OD 25 mm bearings



- 
- Remove the shims and the o-rings from the swinging arm.



- 
- Remove the pin.



- 
- Remove the oil guard.



- 
- Remove the bearings using the suitable tools.

### Specific tooling

**001467Y034 Calliper to extract  $\varnothing$  15-mm bearings**

**001467Y010 Driver for OD 25 mm bearings**



- Fit the new bearings using the suitable tools.

### Specific tooling

020376Y Adaptor handle

020412Y 15-mm guide



To refit, follow the previous operations but in reverse order, observing the prescribed locking torques.

### Locking torques (N\*m)

Screw fixing plate with silent block - frame 36 - 44 Frame-swinging arm bolt 40 - 45 Swinging arm pin - engine 40 - 45

## Shock absorbers

### Removal

- Remove the helmet compartment.
- Remove the battery compartment.
- Unscrew the top fixing screw of the shock absorber to the frame.

#### CAUTION

SUPPORT THE VEHICLE ADEQUATELY.



- Unscrew the bottom fixing screw of the shock absorber to the crankcase.

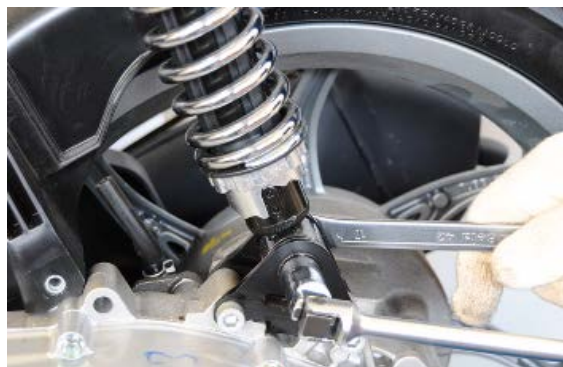

### Refitting

Carry out the operations in the reverse order, observing the prescribed locking torques.

### Locking torques (N\*m)

Shock absorber - frame nut (\*) 20 - 25 Rear shock absorber - bracket 40 - 45

## Centre-stand

---

### REMOVAL

Remove the two return springs from the centre stand.

- Undo the nut shown in the figure.
- Remove the pin from the right side.
- Remove the centre stand.

### CAUTION



SUPPORT THE VEHICLE ADEQUATELY.

### FITTING

Proceed in the reverse order tightening the nut to the specified torque.

### Locking torques (N\*m)

Centre stand bolt nut 20 - 25

---



## INDEX OF TOPICS

**B**RAKING SYSTEM

**IMP FRE**

---

## Guide to diagnosis

At each key ON, if at least one current or memorised system error is not identified:

-the ABS warning light flashes.

When exceeding 5 km/h: -

If no errors are detected the ABS warning light turns off

-if at least one malfunction is detected, the ABS warning light turns on permanently.

The ABS system is disabled.

The system is still fully functional like any other brake system without ABS. The detection of malfunctions may require more or less time depending on the type of fault.

Following the detection logic one or more conditions must persist within a certain time to detect errors.

If during this time one of the conditions is lost and then reappears, the timer is reset and the system is not able to detect the fault. The ABS system continues to be inactive.

---

## Front brake calliper

---

### Removal

- Remove the two brake calliper fixing screws to the fork.



#### CAUTION



**WHEN REMOVING THE FRONT WHEEL, THE BRAKE CALLIPER AND THE DISC, PAY ATTENTION TO THE TONE WHEEL. THE DAMAGE OF THE TONE WHEEL DOES NOT ALLOW A CORRECT USE OF THE ABS-SYSTEM.**

---

### Refitting

Tighten the screws to the prescribed torque.

#### Locking torques (N\*m)

**Front brake calliper fixing screws 19.6 - 24.5**

---

## Front brake disc

---

### Removal

- Remove the front wheel.



#### CAUTION



**WHEN REMOVING THE FRONT WHEEL, THE BRAKE CALLIPER AND THE DISC, PAY ATTENTION TO THE TONE WHEEL. THE DAMAGE OF THE TONE WHEEL DOES NOT ALLOW A CORRECT USE OF THE ABS-SYSTEM.**

- Remove the disc fixing screws.



---

### Refitting

Carry out the operations in the reverse order, observing the prescribed tightening torques.

#### Recommended products

**Loctite 243 Medium strength thread-locking sealant.**

Blue

#### Locking torques (N\*m)

**Disc tightening screw (Apply LOCTITE 243 medium-strength threadlock) 8 - 10 Nm Front wheel axle 44.1 - 49**

Make sure that the distance between the ABS sensor and the tone wheel «X» falls into the prescribed tolerances. Otherwise interpose a washer code .669282 between the sensor and the support.

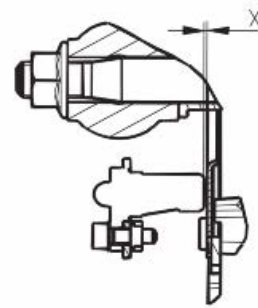

### Characteristic

#### ABS sensor distance - Tone wheel

$X > 0.3 \text{ mm}$

## Disc Inspection

- Check the thickness of the disc (value indicated on the disc itself).

### Characteristic

#### Disc minimum thickness:

3.5 mm



- Using the appropriate tool, measure how much the disc protrudes when the wheel is fitted properly. The protrusion, measured near the external edge of the disc, must be less than 0.1 mm.

- If a value other than that prescribed is detected, remove the front wheel and check how much the disc protrudes. The size measured must be within 0.1 mm. If it is greater replace the disc and conduct the test again.

- If the problem persists, check and replace the wheel rim if necessary.

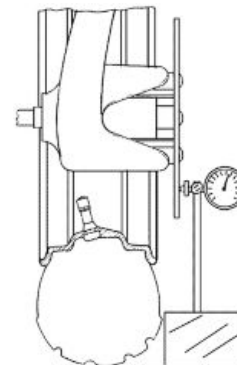

### Specific tooling

020335Y Magnetic mounting for dial gauge

## Front brake pads

## Removal

- Remove the brake calliper.
- Unscrew the pad retaining pins.



- Remove the pad retaining pins.



- Remove the pads.



---

## Refitting

Carry out the operations in the reverse order, observing the prescribed tightening torques.

### Locking torques (N\*m)

**Brake pad fastening screw 15 - 20**

---

## Fill

---

## Front

- Remove the front handlebar cover
- Remove shield.
- Undo the screws that fasten the brake pump reservoir.

**CAUTION**

**WARNING**

KEEP HANDLEBARS IN MIDDLE POSITION DURING THE OPERATION.

**CAUTION**

**WARNING**

MAKE SURE THAT THE FLUID LEVEL INSIDE THE RESERVOIR IS ALWAYS SUFFICIENT TO ALLOW FOR AIR INTAKE INTO THE SYSTEM.



- Remove the brake calliper.
- At on the lever of the brake until it comes into contact with the pads.
- Block the front brake lever in contact with the handlebar.



- Loosen the intake pipe to the modulator by about half a turn.
- Move the brake pads apart until liquid pours from the modulator outlet.
- Tighten the fitting to the specified torque.

DO NOT RELEASE THE BRAKE LEVER UNTIL THE FITTING IS LOCKED IN PLACE.

### Locking torques (N\*m)

#### Pipe - ABS Modulator 20 - 25

- Top-up the level of fluid in the reservoir.
- Close the reservoir.



---

## Brake fluid level check

---

- Remove the front handlebar cover.
- Remove the brake system fluid reservoir cover fixing screws.



- Top fluid off to correct level.

### CAUTION



AVOID CONTACT OF THE BRAKE FLUID WITH THE EYES, SKIN AND CLOTHING, IN CASE OF ACCIDENTAL CONTACT, WASH WITH WATER. THE FLUID OF THE BRAKING CIRCUIT IS HYGROSCOPIC, MEANING IT ABSORBS HUMIDITY FROM THE SURROUNDING AIR. IF THE MOISTURE CONTAINED IN THE BRAKE FLUID EXCEEDS A CERTAIN VALUE, IT WILL RESULT AN INEFFICIENT BRAKING. NEVER USE BRAKE FLUID CONTAINED IN ALREADY OPENED CONTAINERS, OR PARTIALLY USED.

### WARNING



ONLY USE DOT 4-CLASSIFIED BRAKE FLUID. BRAKE CIRCUIT FLUID IS HIGHLY CORROSIVE: DO NOT LET IT COME INTO CONTACT WITH PAINTED PARTS.

### Recommended products

DOT 4 brake fluid Synthetic brake fluid.

SAE J 1703; FMVSS 116; ISO 4925; CUNA NC 956 DOT4

---

## Front brake pump

---

### Removal

---

- Remove the front handlebar cover.
- Remove the stop switch connectors.



- Remove the two brake pump fixing screws.



## Refitting

Carry out the operations in the reverse order, observing the locking torques specified.

### Locking torques (N\*m)

Pump U bolt screw 8

## Rear drum brake

- Remove the silencer.
- Remove the rear wheel hub.
- Tilt the clamps to remove them.



- Fit the new clamps and refit the rear wheel.
- Act on the adjustment screws to adjust the clearance, then tighten them to the specified torque.

### Locking torques (N\*m)

Rear brake adjustment nut 5



**CAUTION**

WHEN FITTING THE SILENCER SUPPORT BRACKET, IT IS NECESSARY TO GREASE THE INSIDE OF THE DUST GAITER AND THE SEALING LIP WITH THE RECOMMENDED PRODUCT AND FILL THE THROAT UNDER THE BEARING.

**Recommended products****Calcium based grease Calcium grease**

Smooth-textured appearance; Ivory colored Specification TL 9150 066, symbol NATO G 460

**Characteristic****Product quantity on inside dust gaiter**

~ 1 cm<sup>3</sup>

**Product quantity on outside dust gaiter**

~ 3 cm<sup>3</sup>

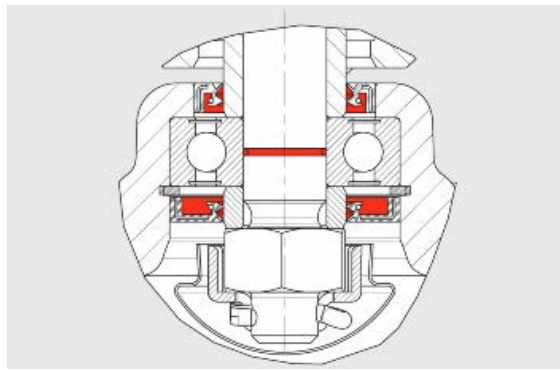
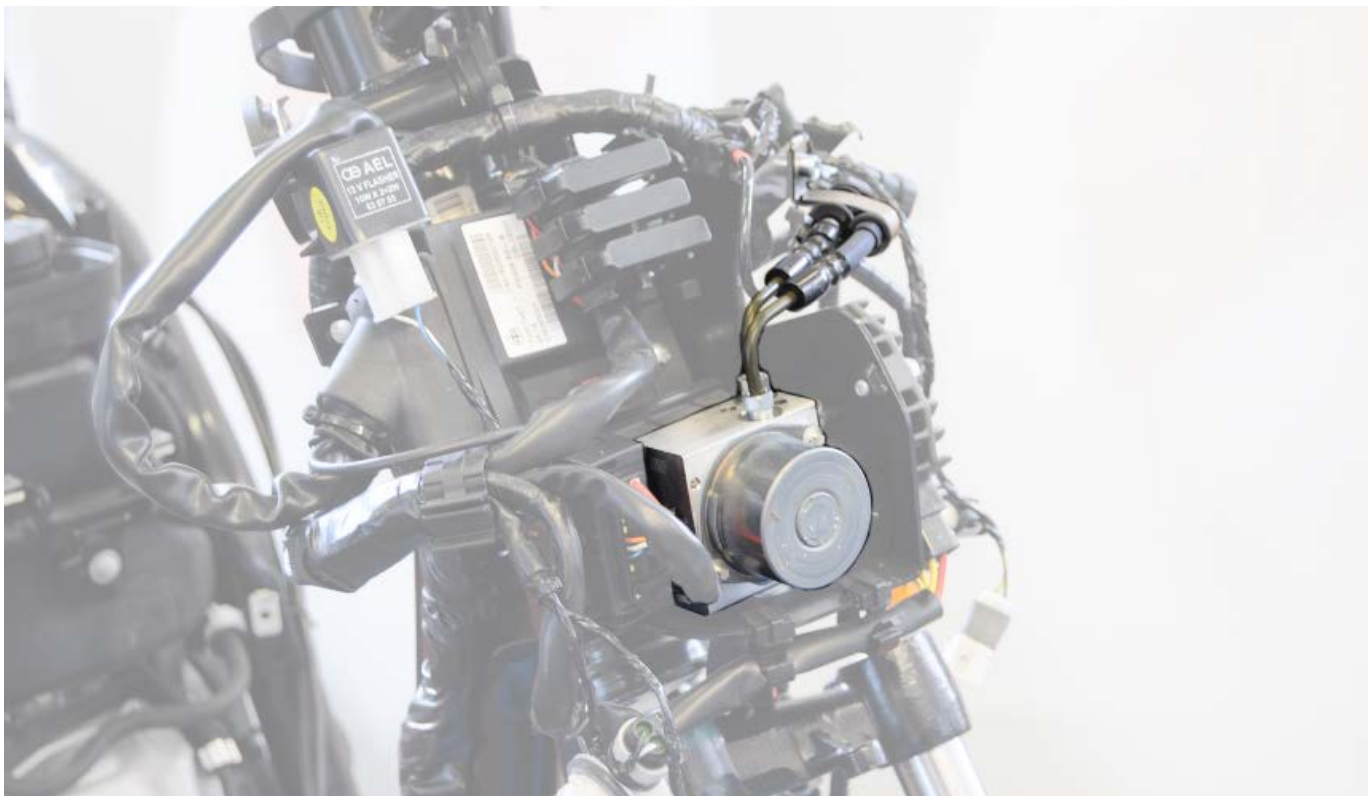
**Brake pipes**





## INDEX OF TOPICS

**CHASSIS**

**CARROZ**

## Seat

---

- Remove the frame central cover.
- Remove the pin lock.



- Remove the pin and remove the saddle.



## Side fairings

---

### FRONT BUMPERS

- Insert the lever into its slot and remove the bumper.



### REAR BUMPERS

- Insert the lever into its slot and remove the bumper.



---

## Rear rack

- Insert a lever into its slot and remove the plastic cover.



- Unscrew and remove the fastening screw beneath the plastic cover.



- Unscrew and remove the fixing screws.



---

## Driving mirrors

- Tighten the adjuster nut on the mirror stem.
- Screw on the mirror into the handlebar all the way down.
- Loosen the mirror until positioning it correctly.
- Loosen the adjuster nut until locking mirror in target position.

### Locking torques (N\*m)

Mirror set screw 24 - 26



## Rear handlebar cover

---

- Remove the front handlebar cover.
- Undo and remove the fixing screws of the rear handlebar cover.



- Disconnect the instrument assembly connector.



## Instrument panel

---

- Remove the instrument assembly fixing screws.



---

## Front handlebar cover

---

- Undo the screw on the front part.



- 
- Unscrew the rear screws.



- 
- Remove the handlebar cover.



---

## Headlight assy.

---

- Remove the connector.



- Remove the rubber protection.



- Remove the plastic retainer.



- Remove the bulb.



---

## Frame central cover

- Open the saddle.
- Unscrew and remove the fixing screws.



- Unscrew and remove the fixing screws.



- Remove the cover.

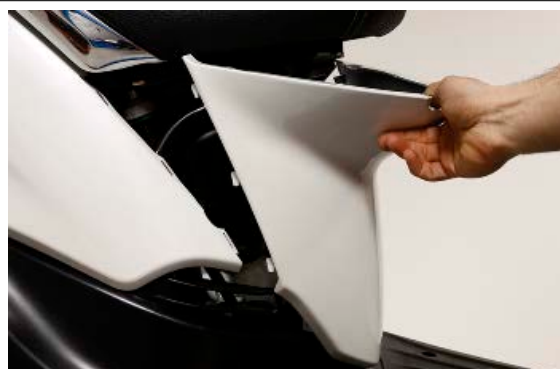

## See also

[Seat](#)

## Legshield

- Remove the leg shield back plate.
- Remove the footrest.
- Remove the front mudguard.



- Undo and remove the screw located under the badge.



- Remove the fixing screws to the spoilers.



- Remove the shield fixing screws.



- Remove the supporting bracket of the saddle opening mechanism.
- Remove shield.



---

## Knee-guard

- Remove the central cover.
- Remove the front side bumpers.
- Remove the footrest.
- Remove the screws under the front central cover.



- Remove the screws under the side bumpers.



- Remove screw located in the storage compartment.



- Remove the screws on the top part of the leg shield back plate.



- Remove the screws on the side under the foot-board.



- Remove the central screw located under the foot-rest.



- Move the leg shield back plate away and remove the cable of the saddle opening lever in the storage compartment.



---

### Removing the ignition key-switch when on \*off\*

- Remove the ignition switch contact retainer.



- Remove the ignition switch contact.



- Remove the lock retainer.



## Taillight assy.

- Remove the luggage compartment plastic protection.
- Remove the rear side bumper protections.
- Remove the screw below the luggage rack.



- Remove the screws under the rear side bumpers.



- Remove the light assembly to reach the bulbs.



- Turn the central bulb holder to remove the stop light.



- Turn bulb to remove it from its holder.



- Remove the side rubber bulb holders to remove the DRL bulbs.



- Remove the daytime running lights bulbs.



- 
- Turn the side bulb holders to remove the turn light bulbs.



- 
- Turn bulb to remove it from its holder.



---

## Footrest

- 
- Remove the frame central cover.
  - Remove the passenger footrests.



- 
- Remove the front screws.



- Remove the screws located below the passenger footrests.



- Remove the screws on the front part of the foot-board.



- Remove the footrest.



---

## Side fairings

### SIDE FAIRING

---

- Remove the helmet compartment. - Remove the luggage rack. - Remove the rear light assembly. - Remove the frame central cover. - Remove the license plate support. - Remove the front fixing screws.



- Remove the rear fastening screw
- Remove the fairings.



## License plate holder

- Remove the rear light assembly.
- Remove the screws located beneath rear light assembly.



- Remove the screws located beneath rear light assembly.



- Remove the screws from the bottom part of the number plate mount.



---

## Air filter

- Remove the fixing screws of the air filter.

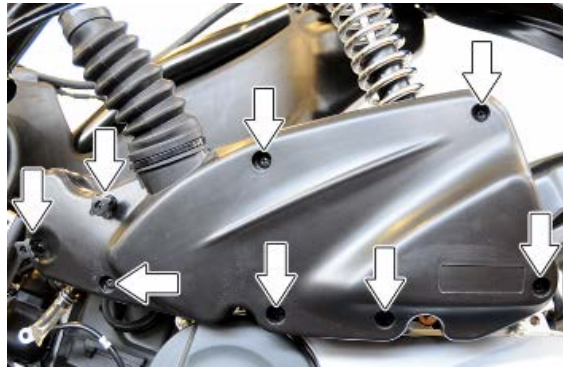

- Remove the fixing screws of the filter element.

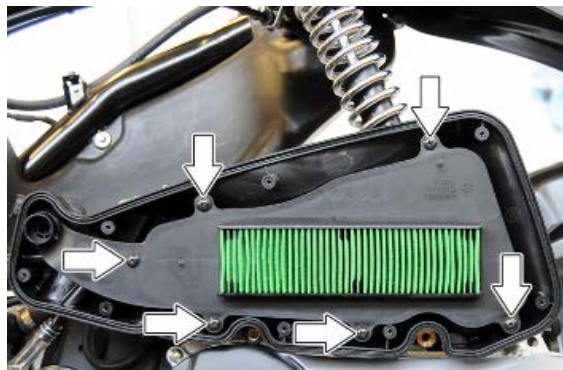

---

## Rear mudguard

- Remove the mudguard to air filter fixing screws.



- Remove the mudguard to crankcase fixing screw.



---

## Helmet bay

Remove the fixing screw of the helmet compartment to the frame.



- Remove the fixing screw of the helmet compartment to the middle cover of the frame.



- Remove the helmet compartment.



---

## spoiler

- Remove the footrest.
- Remove the spoiler to shield fixing screws.



- Remove the fixing screws of the spoiler to the frame.



## Fuel tank

- Remove the side fairings.
- Remove the fuel pipe.



- Disconnect the fuel pipe connector.



- Disconnect the fuel level indicator connector.



- Remove the fixing screws.



- Remove the front fastening screw.



## Front mudguard

- Remove the front wheel

**WARNING**

PROPERLY SUPPORT THE VEHICLE SO AS TO ALLOW STEERING TUBE TO EXIT THE PIPE.



- Remove the mudguard fixing screws.

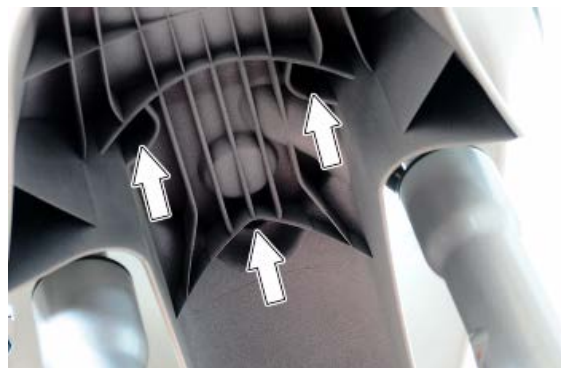

## Battery

- Remove the battery compartment cover fixing screws to access the battery.



**THE FOLLOWING INDICATIONS REFER TO THE VERSION MARKETED IN CHINA.**

The vehicle is equipped with OBD socket (On-Board Diagnostics), located in the battery compartment, used to monitor its correct operation.

**N.B.**

**FOR EVERY DISCONNECTION OF THE BATTERY POWER AND/OR ITS REPLACEMENT, THE RED POSITIVE CABLE OF THE OBD SOCKET SHOULD BE CORRECTLY CONNECTED TO THE POSITIVE POLE.**



## **A**

Air filter: 49, 264

## **B**

Battery: 61, 80, 82, 91, 268

Brake: 239–241, 244–246

Brake fluid: 244

Bulbs:

## **C**

Checks: 75

## **E**

Engine oil: 49

## **F**

Fuel: 207, 219, 266

Fuses: 87

## **H**

Headlight: 54, 253

Horn: 84

Hub oil: 47

## **I**

Identification: 13

Instrument panel: 70, 252

## **M**

Maintenance: 12, 44

Mirrors: 251

## **O**

Oil filter: 51

## **R**

Recommended products: 45

## **S**

Shock absorbers: 236

Spark plug: 46

Suspension: 61

## **T**

Tank: 266

Technical data: 12  
Transmission: 17, 60, 142, 154

**V**  
Vehicle: 10, 13, 132, 133